

## EC/AC axial fans for greenhouses.

Optimized air movement. Maximum yield.

# ebmpapst

The engineer's choice



## Several ideas smarter.

*As technological leader in ventilation and drive engineering, ebm-papst is in demand as an engineering partner in many industries. With over 15,000 different products, we have the right solution for just about any challenge. Our fans and drives are reliable, quiet and energy-efficient.*



### Six reasons that make us your ideal partner:

**Our systems expertise.** As experts in advanced motor technology, electronics and aerodynamics, we offer system solutions from a single source.

**Our spirit of invention.** Our 600 engineers and technicians can develop a solution that precisely fits your needs.

**Our lead in technology.** Our GreenTech EC technology is setting standards worldwide. And our lead is your competitive advantage.

**Beign close to our customers.** With 49 sales offices worldwide.

**Our standard of quality.** Our quality management is uncompromising, at every step and every process.

**Our sustainable approach.** We assume responsibility for future generations with our energy-saving products, eco-friendly processes, and social commitment.

### Best conditions for sustained growth.

Outstanding harvests need corresponding conditions. That's just as true outdoors as it is in greenhouses, where air supply and permeation are especially critical. And that's exactly what the versatile, powerful and especially robust axial fans from ebm-papst deliver.

With their flexibility, they can be adjusted to the needs of a greenhouse's plant stock, providing optimized air movement and uniform circulation throughout. They help to keep temperature and humidity at ideal levels, enabling sustained and vigorous growth. And thanks to modern EC technology, they do so in an especially efficient way.



# The right solution for every greenhouse.

Plants place special demands on greenhouse ventilation. Zones with temperatures that are too high or too low are just as undesirable as zones with too little or too much humidity. Air supply and permeation are important factors for plant growth and can be precisely controlled with axial fans from ebm-papst for a rich, top-quality harvest.

## Horizontal ventilation:

Air is circulated in the greenhouse so as to ensure a uniform temperature around the plants. Guide vanes are used to significantly increase the fan's air throw.

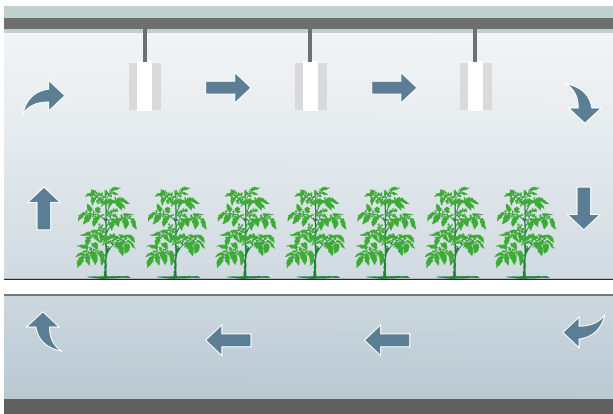

## Ventilation tubes:

With ventilation tubes, the air is supplied underneath the plants, providing an optimum supply of CO<sub>2</sub> to the undersides of their leaves where CO<sub>2</sub> enrichment for photosynthesis takes place. A powerful axial fan forces the air directly into the perforated ventilation tube mounted on its outlet.

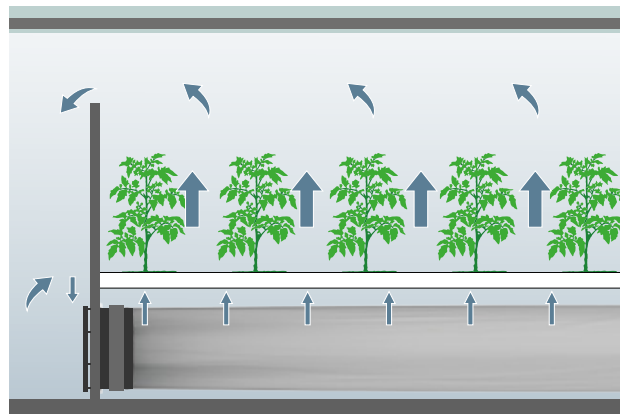

## GreenTech EC axial fans for greenhouses – a clear advantage.

- UV-resistant white housing for maximum light reflection
- Limited shadowing
- Energy-efficient, maintenance-free GreenTech EC motors
- Especially quiet operation
- Fan system with integrated electronics and cable exit on suction side for easy plug & play startup
- Speed adjustable depending on plant stock in greenhouse via MODBUS-RTU or 0–10 V interface

## Sample calculation for 3,500 m<sup>3</sup>/h

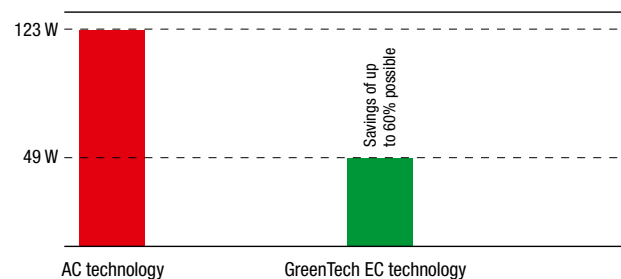

GreenTech EC technology helps reduce electricity costs. Other reductions in operating costs, e.g. reduced water consumption, are also possible depending on the ventilation concept and its exact layout.

# The fast, sure way to your optimum fan solution.

## Clear facts, true values: ebm-papst FanScout, the reliable way to find the right fan.

With just a few well-chosen mouse clicks, our FanScout software guides users to the best fan for their needs. It finds the best solution, taking factors such as operating characteristics, air performance, operating time and space requirements into account, thus enabling advance calculation of life cycle costs. The reliability of the data it produces, in comparison with actual operating data, has been checked and confirmed by TÜV SÜD, the German technical service organization.

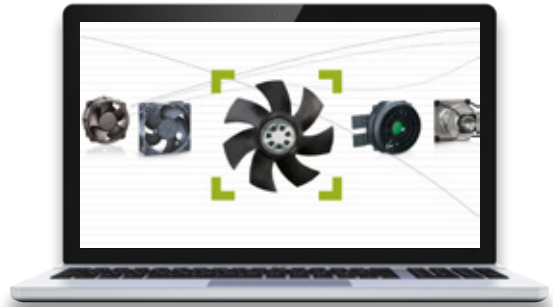

	Size	Item number	Nominal voltage	Frequency	Speed	Max. power consumption	Max. input current	Permissible ambient temperature
			VAC	Hz	rpm	W	A	°C
Horizontal ventilation	350	W4E 350-SN02-35	1~ 230	50/60	1,370/1,500	145/210	0.65/0.95	60/30
		W3G 450-SP02-42	1~ 200-240	50/60	1,100	163	1.34	60
	450	W4E 450-NL05-04	1~ 230	50/60	1,400/1,600	315/460	1.6/2.1	65/45
		W3G 450-SK19-R3	1~ 100-130	50/60	1,400	360	3.1	60
		W3G 450-SL03-H3	1~ 200-277	50/60	1,500	440	1.9	60
500	W3G 500-KD59-07	3~ 380-480	50/60	1,890	1,150	1.8	45	
Ventilation tubes	300	W3G 300-UL11-35	1~ 200-240	50/60	1,800	120	1.0	55
	450	W3G 450-SM02-I3	1~ 200-277	50/60	1,700	750	3.2	45
	500	W3G 500-KD59-08	3~ 380-480	50/60	1,890	1,500	2.4	45
	630	W3G 630-DU23-02	3~ 380-480	50/60	1,510	3,200	5.0	65
	800	W3G 800-NV05-10	3~ 380-480	50/60	1,270	4,000	6.0	45

Data sheets available on request. Subject to technical changes.

### Horizontal ventilation

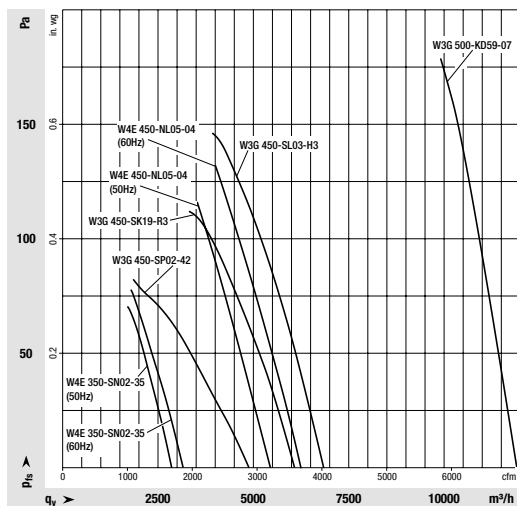

### Ventilation tubes

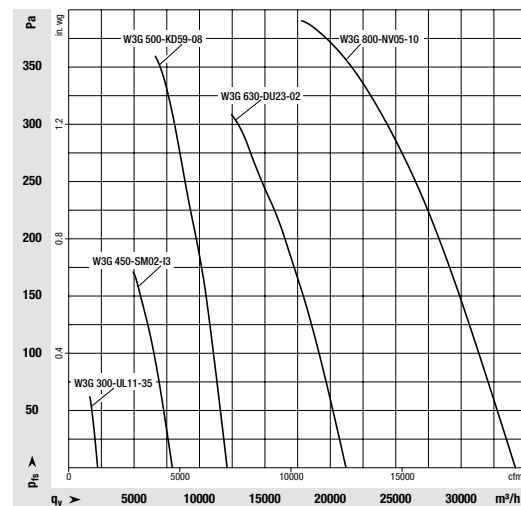

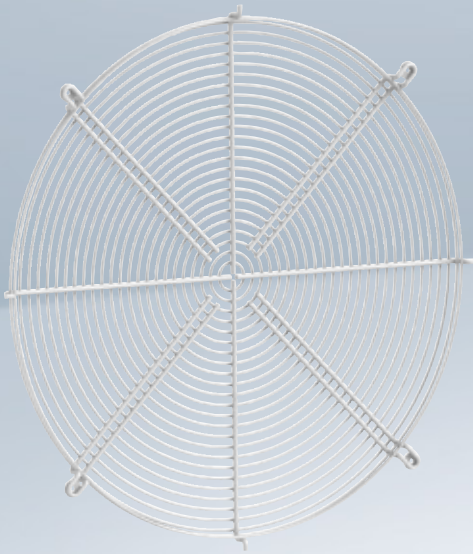

### Guard grill

- + Rugged guard grill**
  - Safe operation
  - Easy cleaning
- + Maximum light reflection**
  - Guard grill powder-coated in white



### Patented double-wall housing

- + Maximum light reflection**
  - Fan housing made of high-quality, UV-resistant white plastic
- + High corrosion resistance**
  - Moisture-resistant composite material
- + Quick installation**
  - Simple and easy to fit with integrated attachment points
- + High efficiency**
  - Innovative and aerodynamic design
- + Easy to clean**
  - Easy-clean surface for maximum hygiene standards

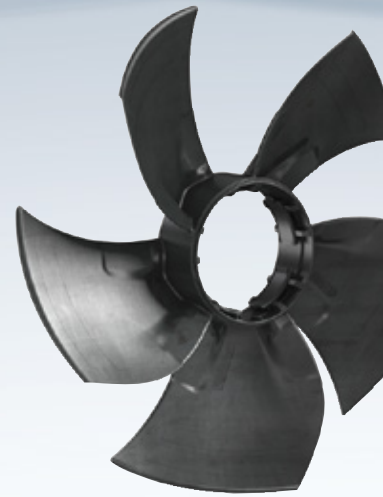

### HyBlade® impeller

- + Tough materials**
  - HyBlade® impeller made of durable composite material
- + Low energy consumption**
  - More efficient than conventional fans thanks to profiled blade geometry and winglets
- + Quiet operation**
  - Aerodynamically optimized shape for noise reduction
  - Carefully matched fan housing and impeller geometry



# The driving force in greenhouses: axial fans in a range of sizes.

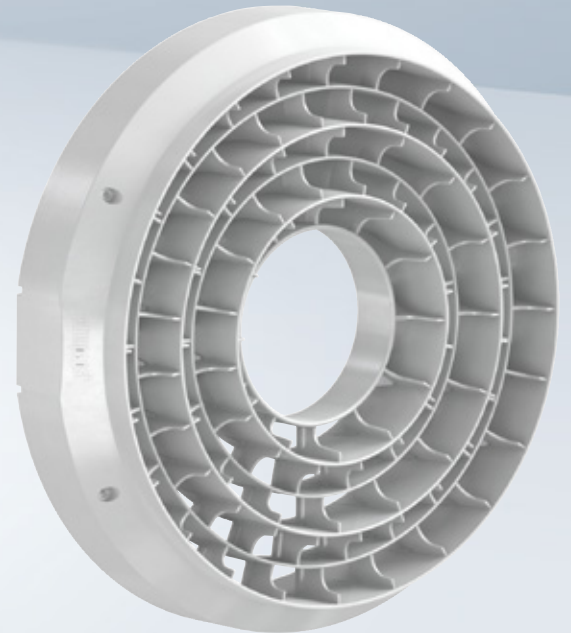

## GreenTech EC motor

- + Unrivaled compact design**
  - Single axial fan unit: Direct integration of EC external-rotor motor with axial impeller
- + Extremely energy-efficient**
  - High efficiency
  - Low self-heating, thus less heat load
- + Extremely robust**
  - Top splash-water protection
- + Ready for the future**
  - Bus connection possible for data tapping, e.g. for condition monitoring
- + Long service life**
  - Extremely durable thanks to maintenance-free ball bearings and high balancing grade



## Motor suspension

- + Integrated splash water protection**
  - Motor cover for protection from splash water



## Guide vanes

- + High air throw**
  - Guide vanes increase air throw
  - Uniform air distribution in greenhouses



Air distribution without guide vanes.

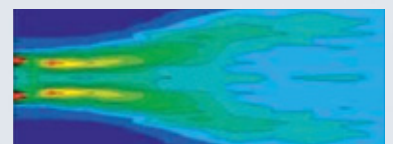

Optimized air distribution with guide vanes to ensure optimum air throw in your greenhouse.

# Showing class no matter the form.

Version A

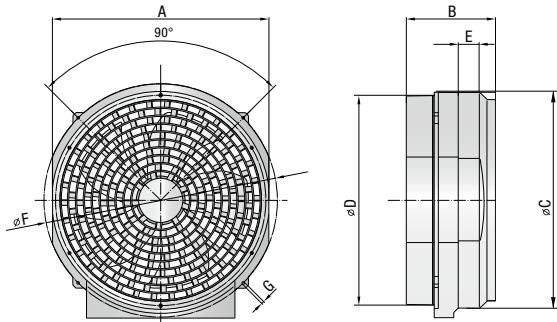

Version B

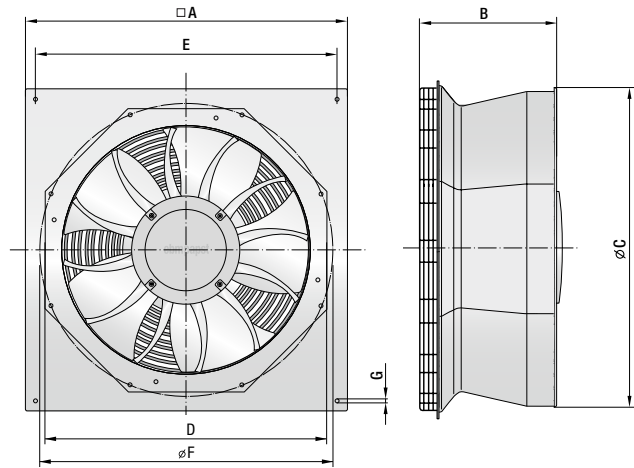

- Motor suspension and guard grill made of robust steel, coated
- Nozzle, streamers and blades made of high-quality composite material
- Connection via integrated cables

- Motor suspension and guard grill made of robust steel, coated
- Blades and nozzle made of high-quality composite material
- Square plate made of sendzimir galvanized steel, coated
- Connection via integrated cables

Version	Size	Item number	A	B	Ø C	Ø D	E	Ø F	Ø G	
Horizontal ventilation: white	350	W4E 350-SN02-35	417	203	422	423	37	460	x	
		W3G 450-SP02-42	548	227	554	551	56	592	x	
	450	W4E 450-NL05-04	548	227	554	551	56	592	x	
		W3G 450-SK19-R3	548	227	554	551	56	592	x	
		W3G 450-SL03-H3	548	227	554	551	56	592	x	
B	500	W3G 500-KD59-07	x	292	669	656	x	680	9 (8x)	
Ventilation tubes: black	300	W3G 300-UL11-35	350	200	353	357	39	393	x	
		450	W3G 450-SM02-I3	548	227	554	551	56	592	x
	B	500	W3G 500-KD59-08	805	292	669	x	750	x	11 (4x)
		630	W3G 630-DU23-02	805	288	696	x	750	x	11 (4x)
		800	W3G 800-NV05-10	1,170	404	1,005	x	1,110	x	14.5 (4x)

All dimensions in mm. Data sheets available on request. The product descriptions in this brochure do not represent assured properties.  
Optional as accessory for size 300/450: attachment clips for fastening tube (Item number 10001-2-5155)

C = minimum tube diameter

## More information? No problem!

For technical questions, contact our expert,  
Maria Tür, at +49 7938 818325  
or maria.tuer@de.ebmpapst.com

**ebm-papst**  
**Mulfingen GmbH & Co. KG**

Bachmühle 2  
74673 Mulfingen  
Germany  
Phone +49 7938 81-0  
Fax +49 7938 81-110  
info1@de.ebmpapst.com

**ebmpapst**

The engineer's choice