

Operating & Maintenance Instructions

Part No	SN1121-A1000, SN1121-A2000, SN1121-A3500		
Description	Differential Pressure Sensor		
Issue	Date	Author	Comments
1	27/04/2021	F. Pagliarini	First Release

Installation

Avoid exposure to vibration and high temperatures. The unit shall be installed according to relevant safety guidelines and requirements. Attention should be paid to local regulations and guidance.

Safety Notice

<p>⚠ CAUTION - SAFETY</p> <p>The sensor is only suitable for a safety extra low voltage supply of up to 57VDC</p> <p>⚠ WARNING</p> <p>Do not operate in an explosive atmosphere</p>

The Differential Pressure Sensor

The differential pressure sensor uses a high-quality mass flow module to convert the movement of clean air and non-aggressive gases into a 0-10VDC differential pressure signal. The differential pressure sensor also features:

- a wide power supply range with reverse polarity protection
- no offset
- full calibration and temperature compensation (-20°C to +85°C)
- factory calibration for Air and N₂

Part Number	SN1121-A1000	SN1121-A2000	SN1121-A3500
Pressure Range	0-1000Pa	0-2000Pa	0-3500Pa

The 0-10VDC signal output is proportional to the pressure difference with respect to the pressure range. For example, a differential pressure of 500Pa measured on a 0-1000Pa sensor gives a 5VDC output but the same differential pressure measured on a 0-2000Pa sensor gives a 2.5VDC output.

Operating & Maintenance Instructions

Specification

Products	SN1121-A1000, SN1121-A2000, SN1121-A3500
Supply Voltage (reverse polarity protected)	SN1121-AXXX: 9.5VDC to 57VDC
Supply Current	10mA
Maximum Load	100K Ω (100uA) when supply voltage < 12Vdc 5k Ω (2mA) when supply voltage >= 12Vdc
Recommended Airline Tube Inner Diameter	3.18 to 3.8mm (1/8 to 3/20inch)
Overpressure Protection	1 bar
Accuracy	3% of reading
Enclosure / Enclosure Rating	Wall mount / IP30
Dimensions	See last page
Weight	100g
Operating Environment	-20°C to +80°C, 90% RH at 40°C max
Media Compatibility	Air, N ₂ , O ₂ , non-condensing
EMC Compliance	BS EN61000-6-3 (emissions) BS EN61000-6-2 (immunity)

Electrical Connections

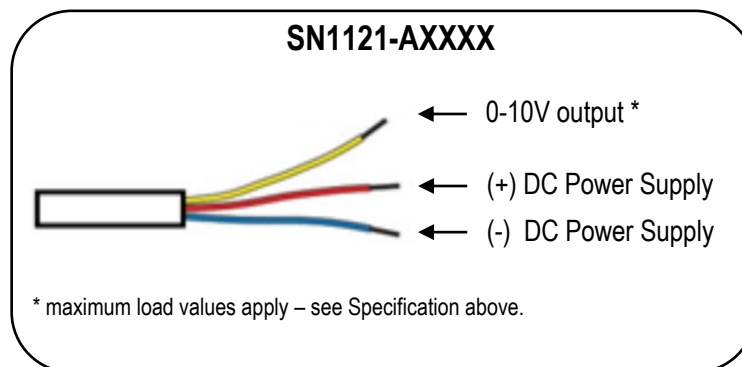

Deviation of Measured Value Due to Length of Airline Tube

It is recommended to use the shortest possible airline tube length to minimise deviation. The table below shows the approximate deviation of measured values against different airline tube lengths:

Length	Deviation of Measured Value
0.5m (20 inch)	-0.40%
1.0m (40 inch)	-0.80%
2.0m (80 inch)	-1.60%
4.0m (160 inch)	-3.20%

WEEE (Waste Electrical and Electronic Equipment)

ebm-papst UK Ltd complies with the Waste Electrical and Electronic Equipment (WEEE) Regulations through membership of a Producer Compliance Scheme (PCS) as a B2B producer. EEE Producer registration number: WEE/CA0209WR

Operating & Maintenance Instructions

End of Life

This product has been designed to consider end-of-life disposal. If the product has come to the end of its life, the unit can be easily disassembled for the components to be recycled. The product has been designed to meet the requirements of the RoHS directive. Refer to the below when dismantling:

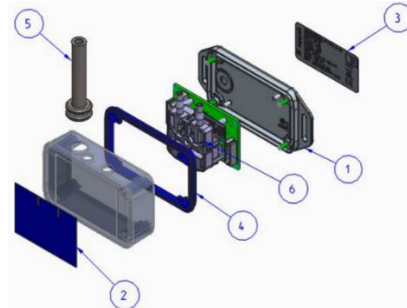

Exploded View of Product

1. Enclosure – polycarbonate
2. Top Label – polyester
3. Rating Label – polyester
4. Seal – thermoplastic elastomers
5. Grommet – polyvinyl chloride
6. Printed Circuit Board Assembly – epoxy resin boded woven glass

Take Back Policy

As part of our commitment to minimise the disposal of Waste Electrical and Electronic Equipment (WEEE) customers can return the product at the end of its life. Please contact us on +44 1245 468555 for details and issue of an end-of-life RMA number.

Transport & Storage

- Store in a dry environment
- Storage temperature: -20°C to +85°C

Dimensions (mm)

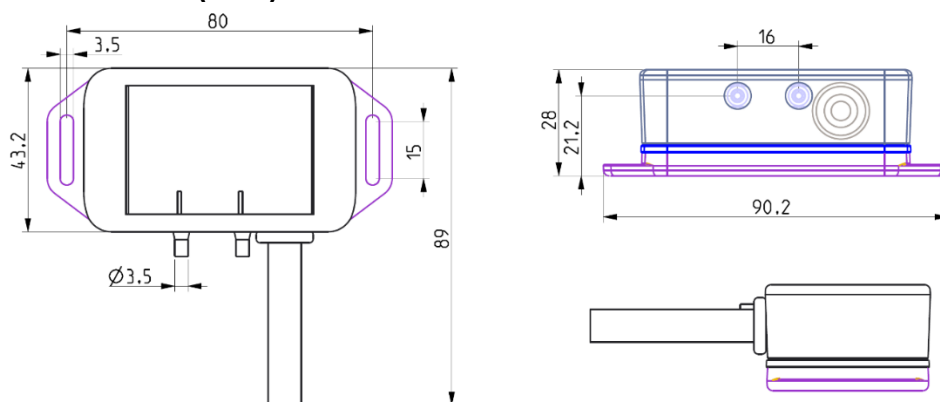

UKCA and CE Certificates

The product has been UKCA and CE marked. The certificates are available upon request info@uk.ebmpapst.com

210-OMI14313-Iss1	SN1121 Differential Pressure Sensor	Page 3 of 3
© ebm-papst UK Ltd 2021	Chelmsford Business Park Chelmsford Essex CM2 5EZ Telephone: +44(0)1245468555 Fax: +44(0)1245466336 e-mail sales@uk.ebmpapst.com	