

EC centrifugal fans - RadiPac

Edition 2017-07

ebmpapst

The engineer's choice

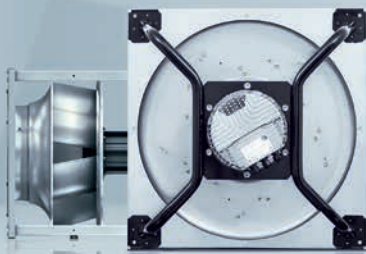

RadiPac: Now complete

The ebm-papst RadiPac EC centrifugal fan series is now complete.

With this catalog, you get the technical documentation for the entire RadiPac family. Some new models have been added and are described briefly below.

The RadiPac standard

These are the fans in sizes 250 to 1000; sizes 250 and 280 are equipped with impellers made of high-quality, injection-molded composites.

Sizes 310 to 1000 include the high-efficiency aluminum impeller with airfoil blades.

This series is designed for maximum efficiency, efficiency thus far unmatched in this breadth by our competitors.

RadiPac with active PFC

Sizes 450, 500 and 560 are now available with the new three-phase 3 kW motor with integrated active PFC.

With these products, we can now fulfill the increasingly frequent requests for total harmonic distortion of no more than 5%.

RadiPacs with new 150 motor

Sizes 450, 500 and 560 have been equipped with the new M3G 150 third-generation (Gen. III) motors. These models have been optimized for minimum installed height for use in tight spaces.

The new RadiPacs stand out with the following features:

- Best overall efficiency
- Comfortable noise level
- Compact design
- Fast availability
- Easy startup with uncomplicated configuration of control electronics
- Finely tuned system with pre-configured motor / control electronics / impeller unit
- Plug & play: fully pre-assembled unit ready to install
- Single source: one contact for everything
- Logistic advantages due to complete unit
- Complete product line without gaps
- No magnets with rare earths

All products in this catalog are grouped together in a collection in our product selection program, FanScout. We can provide you with this collection on request.

Contents

RadiPac: Now complete	2	RadiPac - compact version (Ø 280 - Ø 450):	84
About ebm-papst	4	Aluminum impeller with backward-curved blades; without rotating diffusor on fan outlet. For optimum compactness in all directions.	
Product- & characteristic curves overview	6		
RadiPac - standard (Ø 250 - Ø 1000):	10	RadiPac - ATEX version (Ø 400 - Ø 630):	90
Ø 250 and 280 with composite impellers.		Aluminum impeller with backward-curved blades combined with EC motor with explosion protection according to EN 60079-0.	
Ø 310 to 1000 use the high-efficiency aluminum impeller with airfoil blades.			
Ø 450, 500 and 560 with motors with integrated active power factor correction.		Technology:	
RadiPac - short version (Ø 450 - Ø 560):	76	- Tender specifications	100
Combination of aluminum impellers with airfoil blades with the M3G150 third-generation (Gen. III) motor. For minimum installed height.		- Accessories	102
		- Connection diagrams	114
		- FanScout product selection program	124
		- Technical parameters & scope	126
		ebm-papst agents	130



About ebm-papst

As technological leader for ventilation and drive engineering, ebm-papst is in demand as an engineering partner in many industries. With over 15,000 different products, we provide the right solution for just about any challenge. Our fans and drives are reliable, quiet and energy-efficient.

Six reasons that make us the ideal partner:

Our systems expertise.

You want the best solution for every project. The interrelationships between ventilation and drive engineering must thus be considered as a whole. And that's what we do – with **motor technology** that sets standards, sophisticated **electronics** and **aerodynamic designs** – all from a single source and perfectly matched. These system solutions release unique synergies worldwide. And in particular – they relieve you of a lot of work, so that you can concentrate on your core competency.

The ebm-papst spirit of invention.

In addition to our wide range of products, we are always able to develop customized solutions for you. A diversified team of 600 engineers and technicians works at our three locations in Germany: Mulfingen, Landshut and St. Georgen. Contact us to discuss your next project.

Our lead in technology.

As pioneer and trail-blazer for developing highly efficient EC technology, we are way ahead of other motor manufacturers. Almost all our products are also available with GreenTech EC technology. The list of benefits is long: higher efficiency, maintenance-free, longer service life, sound reduction, intelligent control characteristics and unrivalled energy efficiency with savings of up to 80% compared to conventional AC technology. Let our technology be your competitive advantage as you lead in your industry.

Closeness to our customers.

ebm-papst has 25 production locations worldwide (including facilities in Germany, China and the USA), together with 49 sales offices, each of which has a dense network of sales representatives. You will always have a local contact, someone who speaks your language and knows your market.

Our standard of quality.

Of course you can rely on the highest standards of quality with our products. Our quality management is uncompromising, at every step in every process. This is underscored by our certification according to international standards including DIN EN ISO 9001, TS declaration of conformity and DIN EN ISO 14001.

Our sustainable approach.

Assuming responsibility for the environment, for our employees and for society is an integral part of our corporate philosophy. We develop products with an eye to maximum environmental compatibility, in particular resource-preserving production methods. We promote environmental awareness among our young staff and are actively involved in sports, culture and education. That's what makes us a leading company – and an ideal partner for you.



The story of our success to market and technology pioneer.

- 1963** Founding of **Elektrobau Mulfingen GmbH & Co. KG** by Gerhard Sturm and Heinz Ziehl.
- 1965** First tubeaxial fan developed in EC/DC technology.
- 1966** ebm's success takes off with the new 68 motor.
- 1972** The first ebm foreign subsidiary is established in Sweden.
- 1988** Gerhard Sturm is awarded the Federal Cross of Merit.
- 1990** The sixty-millionth external-rotor fan is produced.
- 1992** Acquisition of **PAPST Motoren GmbH** in St. Georgen.
- 1997** Buyout of the **Landshut** (mvl) plant.
- 1998** Development of first fans with integrated electronics.
- 2003** Change of name to **ebm-papst**.
- 2008** The **HyBlade®** range of fans sets new efficiency standards.
- 2010** **GreenTech** – our sign for energy efficiency and resource preservation.
- 2011** **RadiCal** defines a new standard for EC centrifugal fans.
- 2013** ebm-papst takes over the gearbox specialist Zeitlauf and wins the **German Sustainability Award**.
- 2014** Team partnership with Mercedes AMG PETRONAS Formula 1 team.
- 2015** **RadiPac** pushes the limits of efficiency.
- 2016** **AxiBlade** sets new standards in ventilation, refrigeration and air-conditioning.



Product overview – RadiPac

Standard, Ø 250 - Ø 1000

Ø	Motor	Nominal voltage range VAC	Max. input power kW	Centrifugal fan 	Centrifugal module with support bracket 	Centrifugal module with cube design 	Page ff.
250	M3G 084-DF	1~200-277	0,50	R3G 250-PR04 -H1	K3G 250-PR04 -H2	---	12
	M3G 084-DF	1~200-277	0,75	R3G 250-PR17 -I1	K3G 250-PR17 -I2	---	
	M3G 084-DF	3~380-480	1,18	R3G 250-PR02 -J1	K3G 250-PR02 -J2	---	
280	M3G 084-DF	1~200-277	0,50	R3G 280-PR03 -H1	K3G 280-PR03 -H2	---	18
	M3G 084-DF	1~200-277	0,75	R3G 280-PR04 -I1	K3G 280-PR04 -I2	---	
	M3G 084-FA	3~380-480	1,05	R3G 280-PS10 -J1	K3G 280-PS10 -J2	---	
310	M3G 084-GF	3~380-480	1,23	R3G 310-PT08 -J1	K3G 310-PT08 -J2	---	24
	M3G 112-GA	3~380-480	1,80	R3G 310-PH38 -01	K3G 310-PH38 -02	---	
	M3G 112-GA	3~380-480	2,95	R3G 310-PH58 -01	K3G 310-PH58 -02	---	
355	M3G 112-EA	3~380-480	1,10	R3G 355-PJ75 -01	K3G 355-PJ75 -01	---	30
	M3G 112-GA	3~380-480	1,90	R3G 355-PH49 -01	K3G 355-PH49 -02	---	
	M3G 112-IA	3~380-480	2,68	R3G 355-PI93 -01	K3G 355-PI93 -02	---	
400	M3G 112-IA	3~380-480	2,50	R3G 400-PI92 -01	K3G 400-PI92 -02	---	36
	M3G 150-FF	3~380-480	3,35	R3G 400-PA27 -71	K3G 400-PA27 -71	---	
450	M3G 112-IA	3~380-480	1,74	R3G 450-PI86 -01	K3G 450-PI86 -02	---	40
	M3G 150-FF	3~380-480	2,90	R3G 450-PA23 -71	K3G 450-PA23 -71	---	
	M3G 150-FF	3~380-480	3,19	R3G 450-PA21-C1*	K3G 450-PA21-C1*	---	
	M3G 150-IF	3~380-480	5,25	R3G 450-PB24 -01	K3G 450-PB24 -01	---	
500	M3G 150-FF	3~380-480	3,10	R3G 500-PA26-C1*	K3G 500-PA26-C1*	---	46
	M3G 150-FF	3~380-480	3,45	R3G 500-PA23 -71	K3G 500-PA23 -71	---	
	M3G 150-IF	3~380-480	5,70	R3G 500-PB33 -01	K3G 500-PB33 -01	---	
560	M3G 150-IF	3~380-480	3,06	R3G 560-PB22-C1*	K3G 560-PB22-C1*	---	52
	M3G 150-IF	3~380-480	3,30	R3G 560-PB31 -71	K3G 560-PB31 -71	---	
	M3G 150-NA	3~380-480	5,00	R3G 560-PC04 -01	K3G 560-PC04 -01	---	
630	M3G 150-IF	3~380-480	2,60	R3G 630-PB32 -71	K3G 630-PB32 -71	---	58
	M3G 150-NA	3~380-480	4,68	R3G 630-PC08 -01	K3G 630-PC08 -01	---	
	M3G 200-HF	3~380-480	7,00	---	---	K3G 630-PV04 -01	
	M3G 200-LA	3~380-480	9,78	---	---	K3G 630-PW04 -01	
710	M3G 150-NA	3~380-480	2,96	R3G 710-PC05 -71	K3G 710-PC05 -71	---	64
	M3G 200-LA	3~380-480	7,30	---	---	K3G 710-PV05 -01	
	M3G 200-QA	3~380-480	11,90	---	---	K3G 710-PW06 -01	
800	M3G 150-NA	3~380-480	2,70	R3G 800-PC12 -71	K3G 800-PC12 -71	---	68
	M3G 200-QA	3~380-480	7,90	---	---	K3G 800-PV13 -01	
	M3G 200-QA	3~380-480	11,30	---	---	K3G 800-PW07 -01	
1000	M3G 200-QA	3~380-480	6,34	---	---	K3G A00-PV03 -01	72

* with active-PFC

* with active-PFC

Data is subject to change without notice at ebmpapst discretion.

Product- & characteristic curves overview – RadiPac

Standard, Ø 250 - Ø 1000

Type R3G... motor impellers are available in sizes 250 to 560 for all impeller/motor combinations. For sizes 630 to 800, these versions are only available in combination with the lightweight size 150 motor. Operation of a type R3G... motor impeller requires an inlet ring and a motor mounting of suitable dimensions to be provided by the customer.



Type K3G... centrifugal fans are also available in sizes 250 to 560 and for all impeller/motor combinations in a ready-to-install design with support struts for wall mounting. For sizes 630 to 800, these versions are only available in combination with the lightweight size 150 motor. The K3G “spider” design includes the motor impeller, a welded support strut assembly, an inlet ring and a square mounting plate.



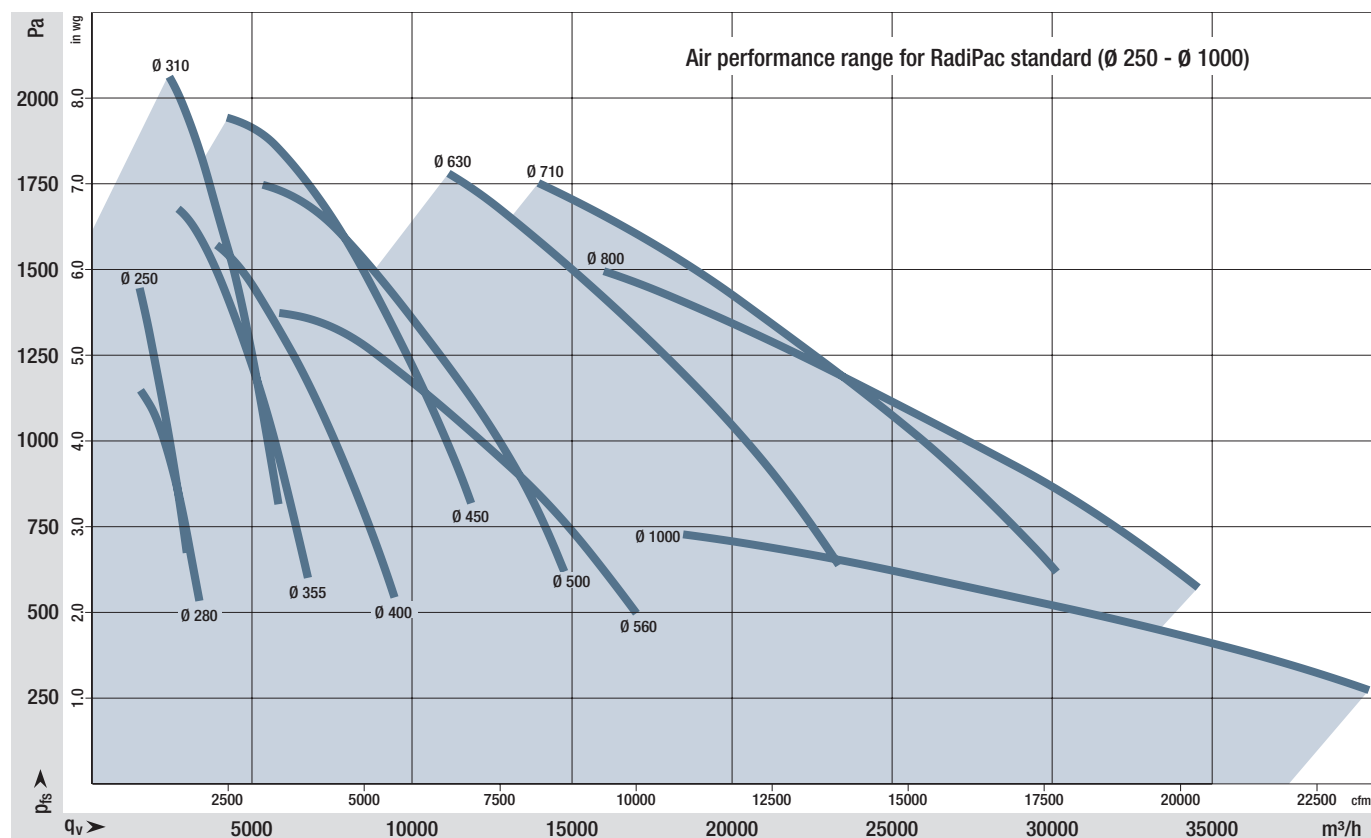

Type K3G... centrifugal fans with impeller diameters 630 to 1000 and the “large” size 200 motor are only available in the cube design intended for floor mounting. The struts are extruded aluminum profile, the corner joints are made of die-cast aluminum, and the motor mounting plate, the inlet ring and the nozzle plate are made of galvanized sheet steel. This version is not suitable for wall mounting.



The graph shows the maximum air performance for each size. If less performance is required, variants with smaller motors can be used. This saves additional costs. The right fan for every application!

Product overview – RadiPac

Standard, Ø 250 - Ø 800 with reversed nozzle plate or with improved corrosion protection

Ø	Motor	Nominal voltage range VAC	Max. input power kW	Centrifugal module with support bracket with reversed nozzle plate 	Centrifugal module with support bracket and improved corrosion protection 	Centrifugal module with cube design and improved corrosion protection 
250	M3G 084-DF	1~200-277	0,50	---	K3G 250-PR04 -H3	---
	M3G 084-DF	1~200-277	0,75	---	K3G 250-PR17 -I3	---
	M3G 084-DF	3~380-480	1,18	---	K3G 250-PR02 -J3	---
280	M3G 084-DF	1~200-277	0,50	---	K3G 280-PR03 -H3	---
	M3G 084-DF	1~200-277	0,75	---	K3G 280-PR04 -I3	---
	M3G 084-FA	3~380-480	1,05	---	K3G 280-PS10 -J3	---
310	M3G 084-GF	3~380-480	1,23	K3G 310-PT08 -J4	K3G 310-PT08 -J3	---
	M3G 112-GA	3~380-480	1,80	K3G 310-PH38 -05	K3G 310-PH38 -32	---
	M3G 112-GA	3~380-480	2,95	K3G 310-PH58 -07	K3G 310-PH58 -32	---
355	M3G 112-EA	3~380-480	1,10	K3G 355-PJ75 -05	K3G 355-PJ75 -02	---
	M3G 112-GA	3~380-480	1,90	K3G 355-PH49 -05	K3G 355-PH49 -32	---
	M3G 112-IA	3~380-480	2,68	K3G 355-PI93 -05	K3G 355-PI93 -32	---
400	M3G 112-IA	3~380-480	2,50	K3G 400-PI92 -05	K3G 400-PI92 -32	---
	M3G 150-FF	3~380-480	3,35	K3G 400-PA27 -75	K3G 400-PA27 -B1	---
450	M3G 112-IA	3~380-480	1,74	K3G 450-PI86 -05	K3G 450-PI86 -32	---
	M3G 150-FF	3~380-480	2,90	K3G 450-PA23 -75	K3G 450-PA23 -B1	---
	M3G 150-IF	3~380-480	5,25	K3G 450-PB24 -05	K3G 450-PB24 -31	---
500	M3G 150-FF	3~380-480	3,45	K3G 500-PA23 -75	K3G 500-PA23 -B1	---
	M3G 150-IF	3~380-480	5,70	K3G 500-PB33 -05	K3G 500-PB33 -31	---
560	M3G 150-IF	3~380-480	3,30	K3G 560-PB31 -75	K3G 560-PB31 -B1	---
	M3G 150-NA	3~380-480	5,00	K3G 560-PC04 -05	K3G 560-PC04 -31	---
630	M3G 200-HF	3~380-480	7,00	---	---	K3G 630-PV04 -02
	M3G 200-LA	3~380-480	9,78	---	---	K3G 630-PW04 -02
710	M3G 200-LA	3~380-480	7,30	---	---	K3G 710-PV05 -02
	M3G 200-QA	3~380-480	11,90	---	---	K3G 710-PW06 -02
800	M3G 200-QA	3~380-480	7,90	---	---	K3G 800-PV13 -02
	M3G 200-QA	3~380-480	11,30	---	---	K3G 800-PW07 -02

Centrifugal module with support bracket and reversed mounting plate:

Type K3G... centrifugal fans are available in sizes 310 to 560 in an additional mechanical design with a reversed mounting plate. In the standard versions (see pages 6-7), the circumferential chamfer on the mounting plate faces upstream. In the “reversed” version described here, the chamfer faces downstream.



Centrifugal module with support bracket / with cube design and corrosion protection:

The ready-to-install K3G... centrifugal fans in sizes 250 to 800 are also available in a version with enhanced corrosion protection. In this version, all metal surfaces have an additional coating. The color used is black.

Data is subject to change without notice at ebm-papst discretion.



Product overview – RadiPac

Short version Ø 450 - Ø 560 / Compact version Ø 280 - Ø 450 / ATEX version Ø 400 - Ø 630

Ø	Motor	Nominal voltage range VAC	Max. input power kW	Centrifugal fan (Short version) 	Centrifugal module with support bracket (Short version) 	Centrifugal module with cube design 	Page ff.
450	M3G 150-FF	3~380-480	4,50	R3G 450-PA31 -03	K3G 450-PA31 -03	---	76
500	M3G 150-FF	3~380-480	3,80	R3G 500-PA28 -03	K3G 500-PA28 -03	---	
	M3G 150-FF	3~380-480	4,20	R3G 500-PB24 -03	K3G 500-PB24 -03	---	
560	M3G 150-FF	3~380-480	4,40	R3G 560-PB31 -03	K3G 560-PB31 -03	---	



Short version:

In addition to the standard versions, size 450, 500 and 560 RadiPac centrifugal fans in the R3G (motor impeller) and K3G (modular) design variants are also combined with the third-generation M3G 150 motor. The result is a higher-performance version with additional functionality such as programmable inputs and outputs and an LED status indicator. Moreover, mounting the impeller on the base flange results in a lower installed height.

Ø	Motor	Nominal voltage range VAC	Max. input power kW	Centrifugal fan (Compact version) 	Centrifugal module with support bracket 	Centrifugal module with cube design 	Page ff.
280	M3G 084-GF	3~380-480	0,99	R3G 280-AJ14 -C1	---	---	84
310	M3G 112-GA	3~380-480	1,65	R3G 310-BC38 -01	---	---	
355	M3G 112-GA	3~380-480	1,73	R3G 355-BD43 -01	---	---	
400	M3G 150-FF	3~380-480	2,84	R3G 400-AS23 -01	---	---	
450	M3G 150-FF	3~380-480	2,38	R3G 450-AS24 -01	---	---	

Compact version:

RadiPac centrifugal fans in sizes 280 to 450 are also available as compact R3G motor impellers. The aluminum impeller without airfoil blades and without radial diffusor has a very small footprint and is intended for use in single-inlet scroll or half-scroll housings.

Ø	Motor	Nominal voltage range VAC	Max. input power kW	Centrifugal fan 	Centrifugal module with support bracket 	Centrifugal module with cube design (ATEX version) 	Page ff.
400	M3G 150-FF	3~380-480	3,10	---	---	K3G 400-AQ23 -90	90
450	M3G 150-FF	3~380-480	2,95	---	---	K3G 450-AQ24 -90	
500	M3G 150-FF	3~380-480	2,97	---	---	K3G 500-AP25 -90	
560	M3G 150-FF	3~380-480	2,94	---	---	K3G 560-AP23 -90	
630	M3G 150-NA	3~380-480	2,97	---	---	K3G 630-AP01 -90	

ATEX fans:



RadiPac centrifugal fans for use in potentially explosive atmospheres. These fans are available in sizes 400 to 630.

The combination of high-efficiency EC motor and integrated control electronics for use in potentially explosive atmospheres of Zones 1 and 2 is unique and simplifies the use of fans in such environments for the operator.

Data is subject to change without notice at ebm-papst discretion.

RadiPac - standard:

Type R3G... RadiPac motor impellers are available in sizes 250 to 560 for all impeller/motor combinations.

For sizes 630 to 800, these versions are only available in combination with the lightweight size 150 motor.

Operation of a type R3G... motor impeller requires an inlet ring and a motor mounting of suitable dimensions to be provided by the customer.

Type K3G... centrifugal fans are also available in sizes 250 to 560 and for all impeller/motor combinations in a ready-to-install design with support struts for wall mounting.

For sizes 630 to 800, these versions are only available in combination with the lightweight size 150 motor.

The K3G “spider” design includes the motor impeller, a welded support strut assembly, an inlet ring and a square mounting plate.

Type K3G... centrifugal fans with impeller diameters 630 to 1000 and the “large” size 200 motor are only available in the cube design intended for floor mounting.

The struts are extruded aluminum profile, the corner joints are made of die-cast aluminum, and the motor mounting plate, the inlet ring and the nozzle plate are made of galvanized sheet steel.

This version is not suitable for wall mounting.



EC centrifugal fans – RadiPac

Standard, Ø 250 - Ø 1000



EC centrifugal fans – RadiPac

backward curved, Ø 250

- **Material:** Support bracket: Steel, painted black
Support plate and inlet ring: Sheet steel, galvanized
Impeller: PP plastic
Rotor: Painted black
Electronics housing: Die-cast aluminium
- **Number of blades:** 6
- **Direction of rotation:** Clockwise viewed toward rotor
- **Degree of protection:** IP 55
- **Insulation class:** "F"
- **Installation position:** Shaft horizontal or rotor on bottom, rotor on top on request
- **Condensation drainage holes:** Rotor side
- **Mode:** Continuous operation (S1)
- **Mounting:** Maintenance-free ball bearings



Nominal data

Type	Motor	Curve	Nominal voltage range	Frequency	Speed ⁽¹⁾	Max. Input power ⁽¹⁾	Max. Input current ⁽¹⁾	Perm. ambient temp.	Weight	Techn. features and connection diagram
Type	Motor	VAC	Hz	rpm	kW	A	°C	kg		
*3G 250	M3G 084-DF	Ⓐ 1~200-277	50/60	3080	0,50	2,30	-25..+40	4,2	P. 118 / RP3)	
*3G 250	M3G 084-DF	Ⓑ 1~200-277	50/60	3450	0,75	3,30	-25..+40	4,6	P. 118 / RP3)	
*3G 250	M3G 084-DF	Ⓒ 3~380-480	50/60	4000	1,18	1,80	-25..+40	4,5	P. 119 / RP4)	

Subject to change

(1) Nominal data at operating point with maximum load and 230 or 400 VAC.

Curves

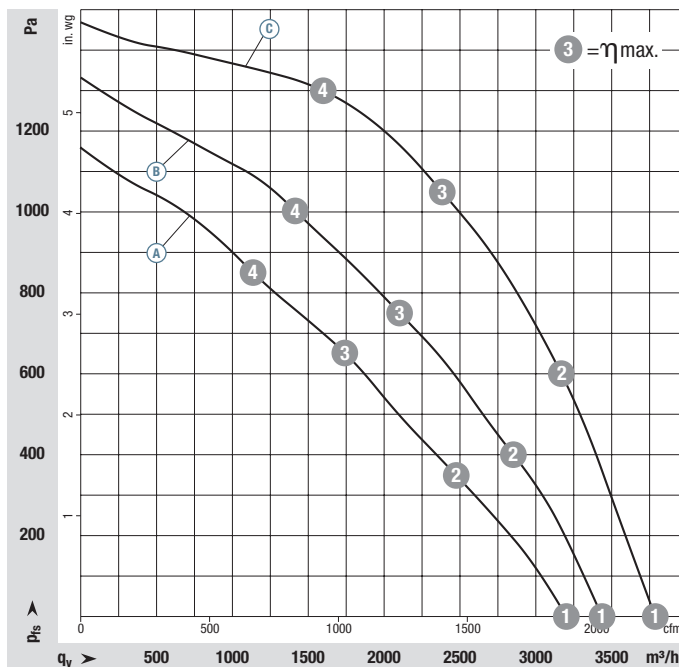

	n rpm	P _{ed} kW	I A	L _{wA} dB(A)
Ⓐ 1	3380	0,49	2,16	84
Ⓐ 2	3125	0,52	2,29	77
Ⓐ 3	3080	0,50	2,30	74
Ⓐ 4	3220	0,50	2,30	78
Ⓑ 1	3645	0,63	2,74	87
Ⓑ 2	3490	0,73	3,19	82
Ⓑ 3	3450	0,75	3,30	78
Ⓑ 4	3500	0,72	3,15	82
Ⓒ 1	4000	0,82	1,27	91
Ⓒ 2	4000	1,11	1,72	86
Ⓒ 3	4000	1,18	1,80	83
Ⓒ 4	4000	1,06	1,64	83

Air performance measured according to: ISO 5801, installation category A, with ebm-papst inlet ring without contact protection. Intake-side sound level: L_{wA} according to ISO 13347, L_{pA} measured at 1 m distance from fan axis. The values given are only applicable under the specified measuring conditions and may differ depending on the installation conditions. In the event of deviation from the standard configuration, the parameters must be checked in installed condition. See Page 126 ff. for detailed information.

- **Technical features:** See connection diagram P. 118 f.
- **EMC:** (A) (B) Interference emission according to EN 61000-6-3
 - (C) Interference emission according to EN 61000-6-3, except EN 61000-3-2 for professionally used equipment with a total rated power greater than 1 kW
- (A) (B) (C) Immunity to interference according to EN 61000-6-2
 - (A) (B) Circuit feedback according to EN 61000-3-2/3
- **Touch current:** $\leq 3,5$ mA according to IEC 60990 (measuring circuit Fig. 4)
- **Cable exit:** Variable
- **Protection class:** I (with customer connection of protective earth)
- **Conformity with standards:** EN 61800-5-1, CE; (A) (B) EN 60335-1
- **Approvals:** C22.2 Nr.77 + CAN/CSA-E60730-1, UL 1004-7 + 60730
- **Efficiency:** Ecodesign EU regulation EU 327/2011



Weight centrifugal fan

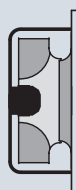

Weight centrifugal module with support bracket

Centrifugal fan	kg	Inlet ring with one pressure tap	Centrifugal module with support bracket	kg
R3G 250-PR04 -H1	4,2	96355-2-4013	K3G 250-PR04 -H2	8,5
R3G 250-PR17 -I1	4,6	96355-2-4013	K3G 250-PR17 -I2	8,9
R3G 250-PR02 -J1	4,5	96355-2-4013	K3G 250-PR02 -J2	8,8

EC centrifugal fans – RadiPac

backward curved, Ø 250



R3G 250-PR04-H1 (Centrifugal fan)

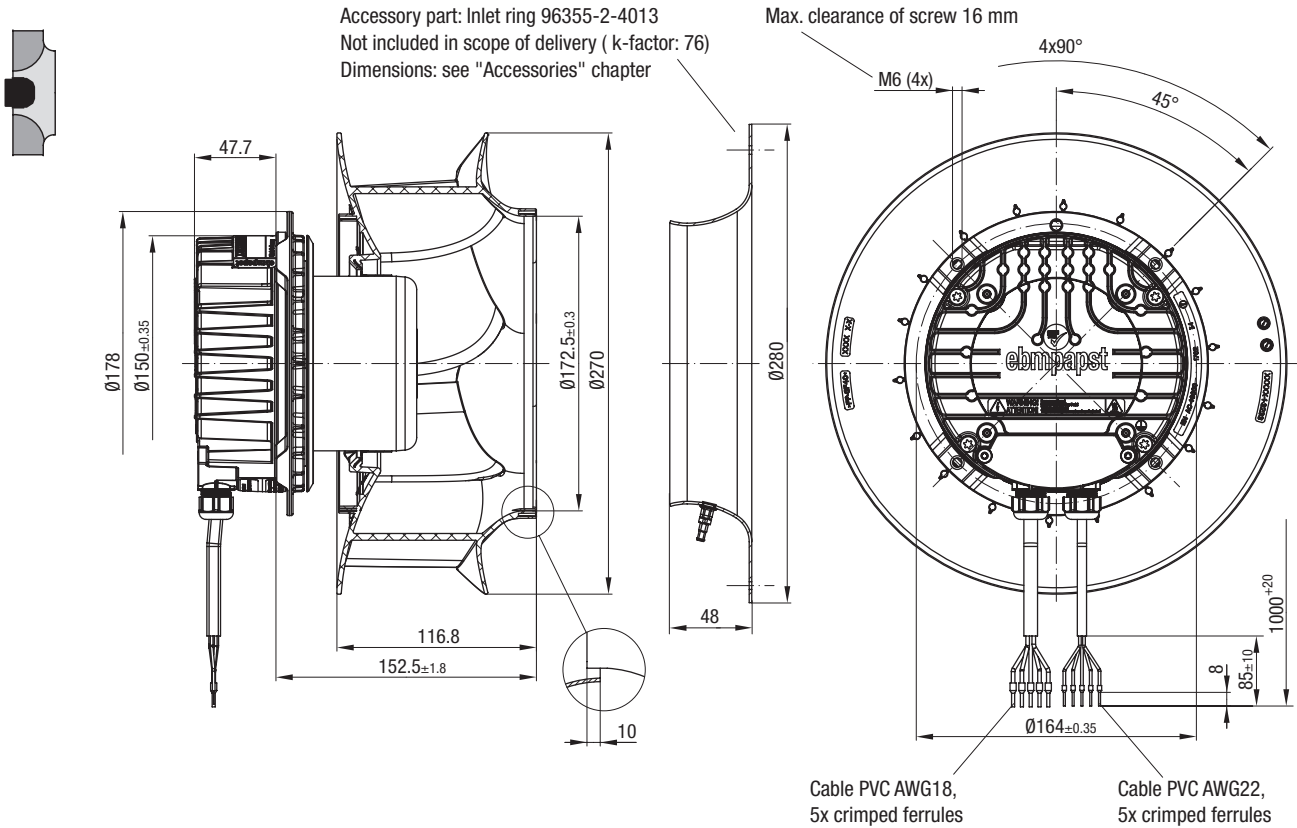

K3G 250-PR04-H2 (Centrifugal module with support bracket)

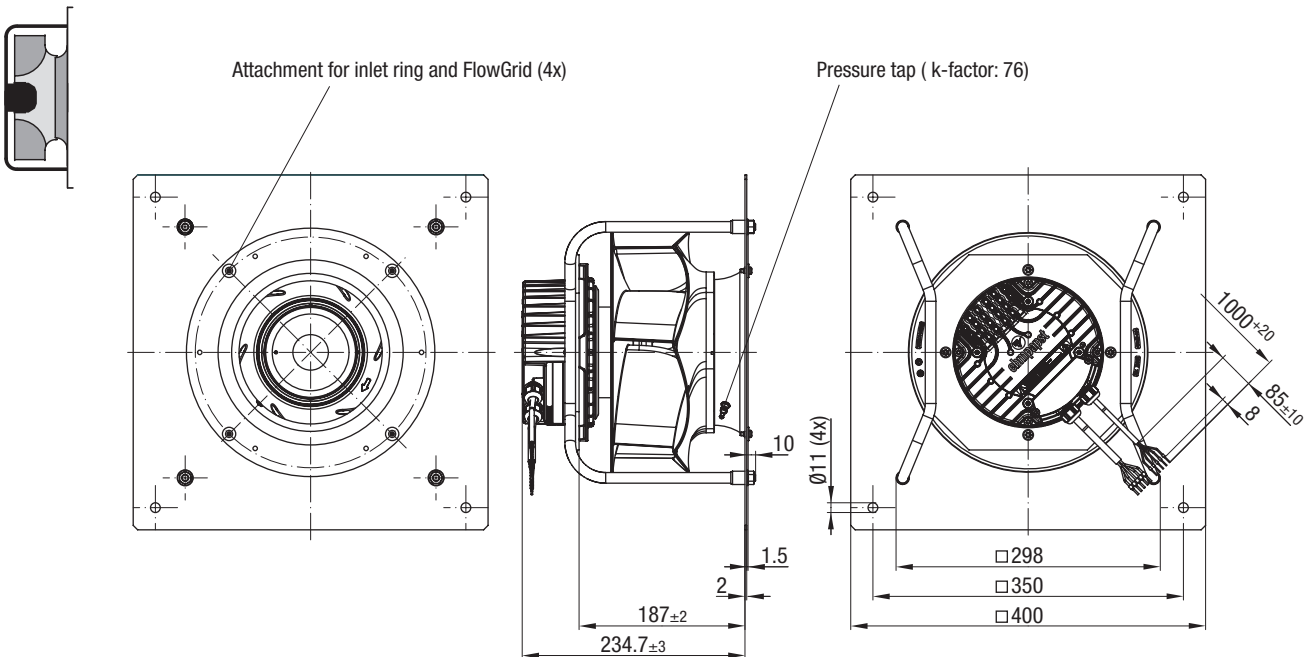

EC centrifugal fans – RadiPac

backward curved, Ø 250



Information

Ø 250

Ø 280

Ø 310

Ø 355

Ø 400

Ø 450

Ø 500

Ø 560

Ø 630

Ø 710

Ø 800

Ø 1000

Short version

Compact version

ATEX version

Technology

Agents

2017-07

R3G 250-PR17-I1 (Centrifugal fan)

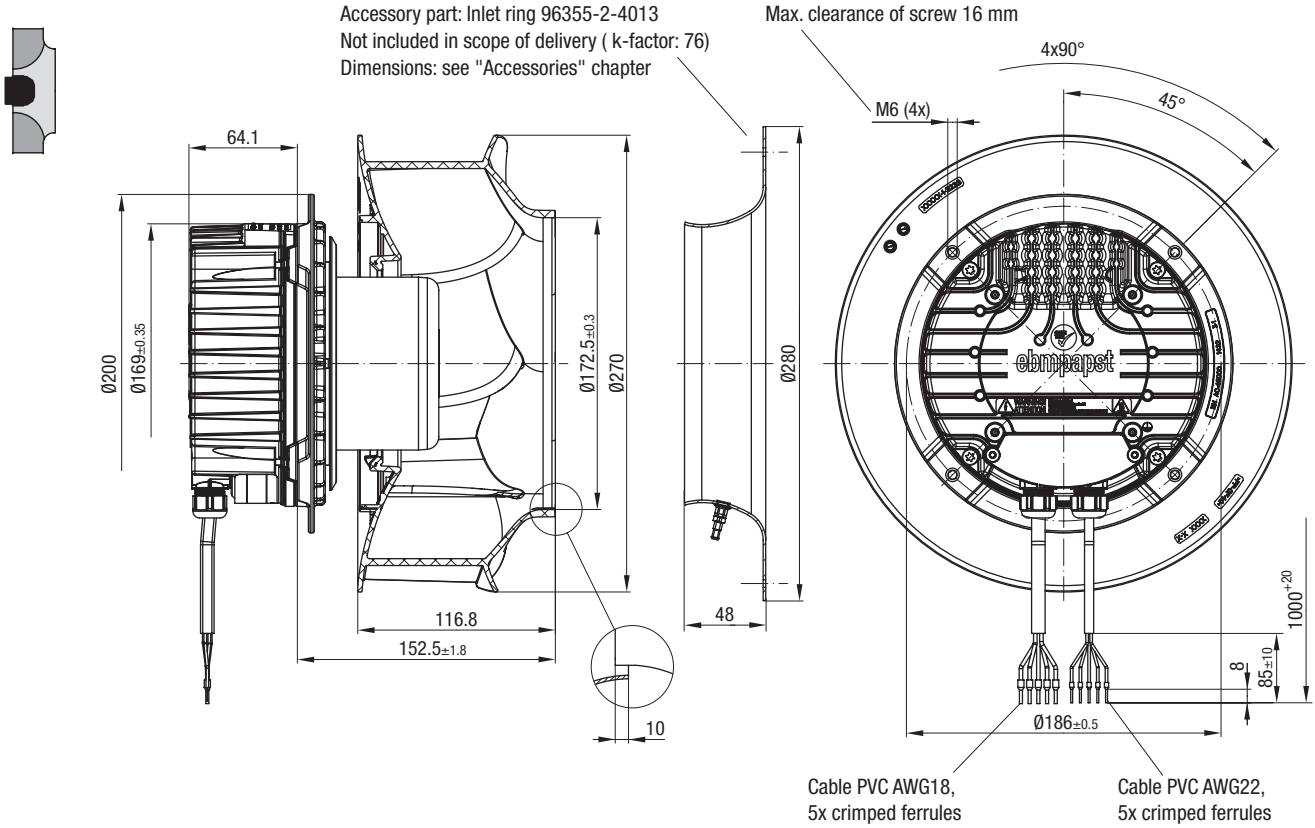

K3G 250-PR17-I2 (Centrifugal module with support bracket)

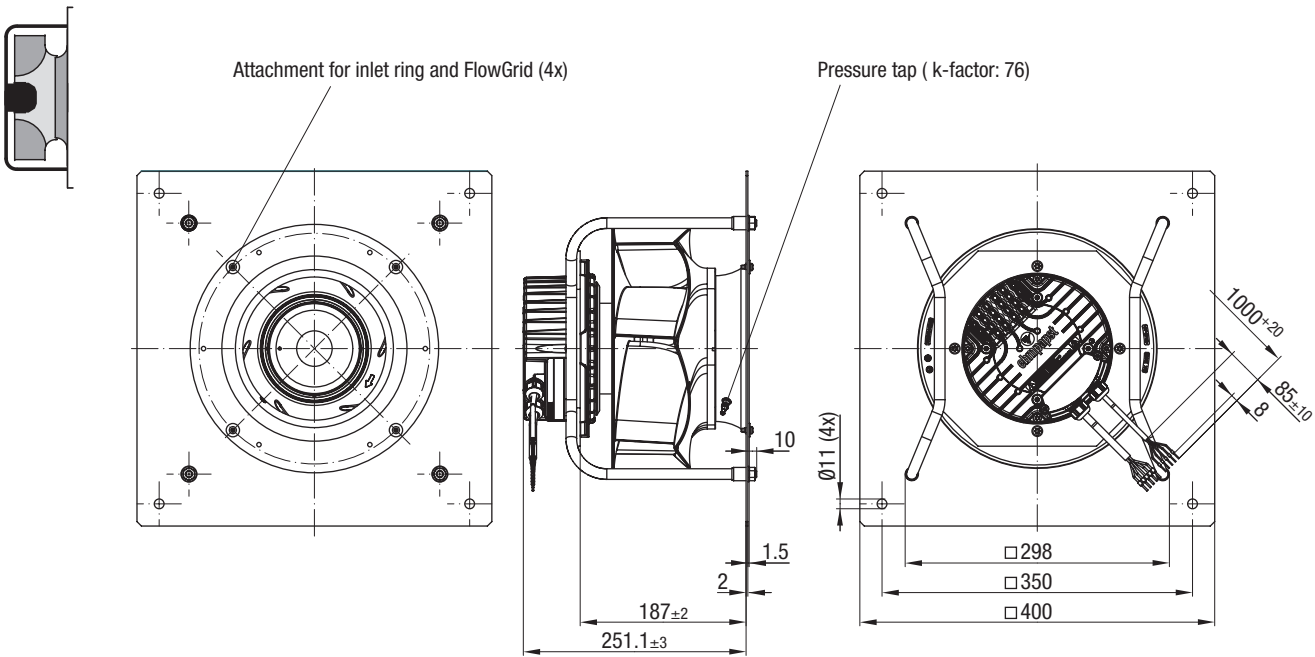

EC centrifugal fans – RadiPac

backward curved, Ø 250



R3G 250-PR02-J1 (Centrifugal fan)

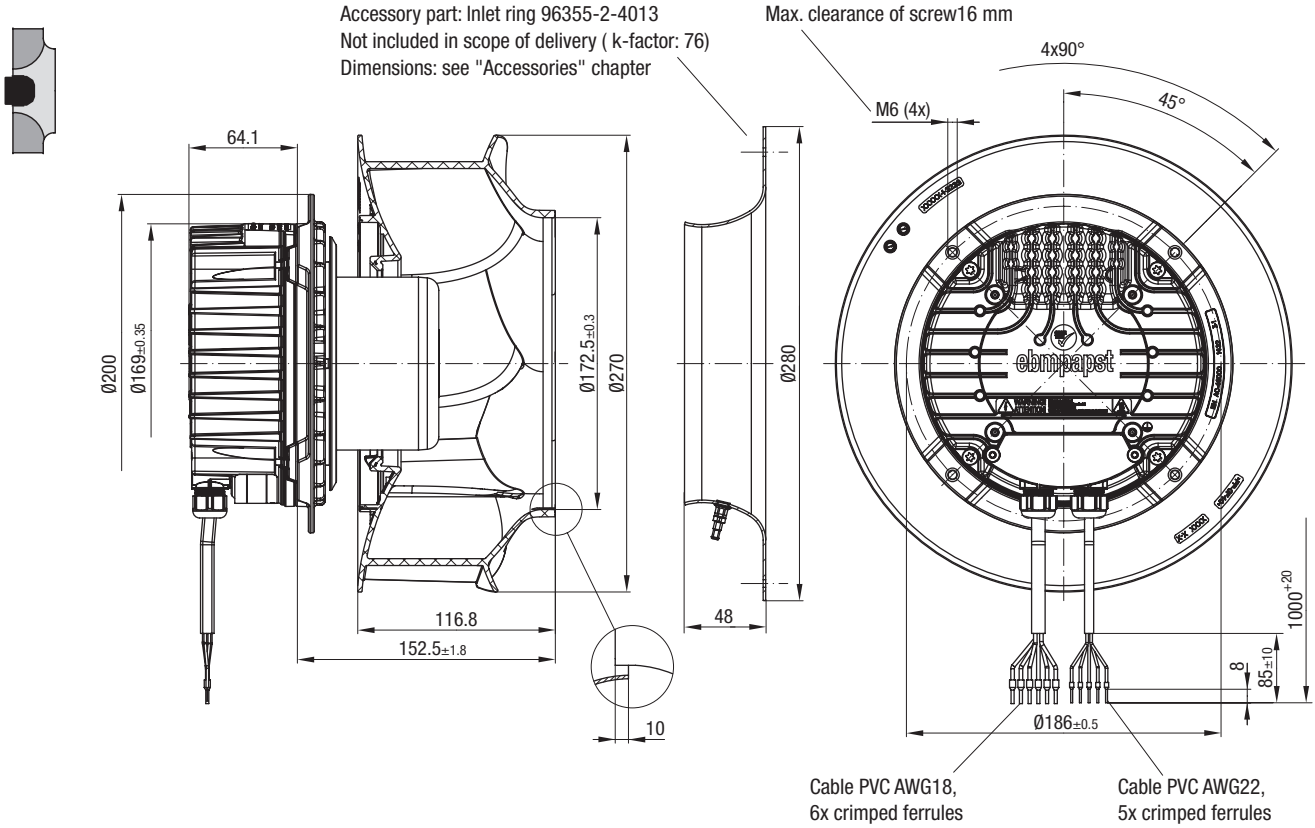

K3G 250-PR02-J2 (Centrifugal module with support bracket)

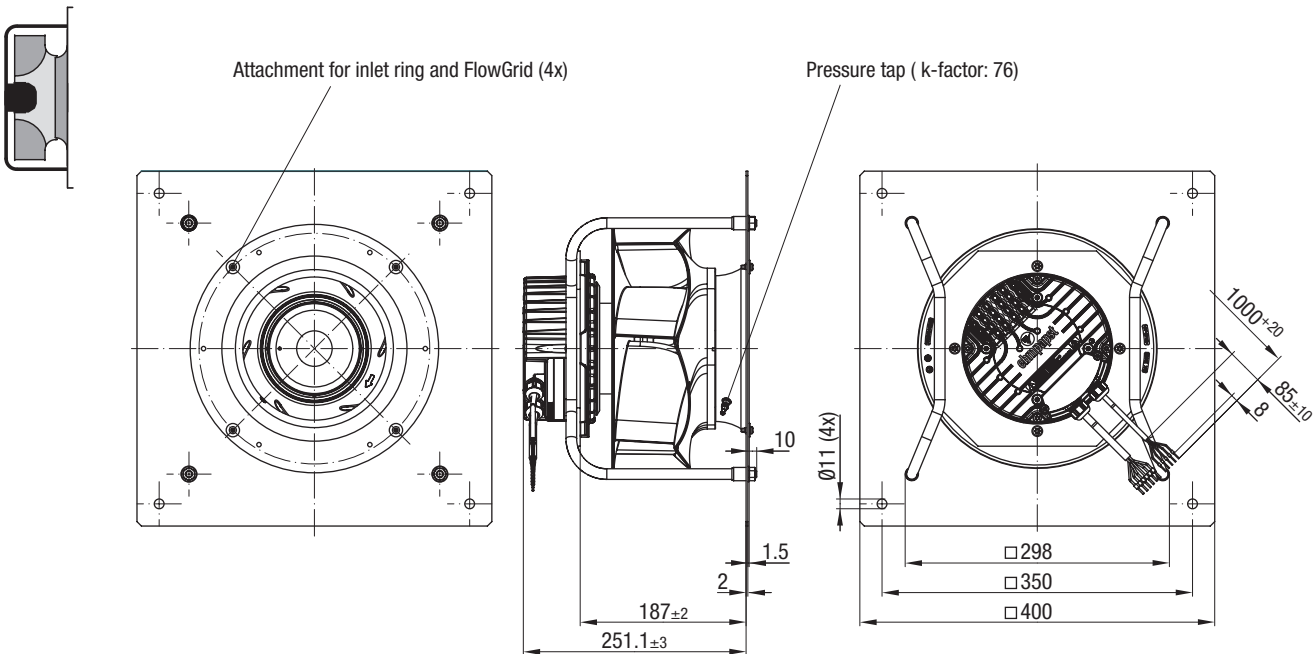

Agents	Technology	ATEX version	Compact version	Short version	Ø 1000	Ø 800	Ø 710	Ø 630	Ø 560	Ø 500	Ø 450	Ø 400	Ø 355	Ø 310	Ø 280	Ø 250	Information
--------	------------	--------------	-----------------	---------------	--------	-------	-------	-------	-------	-------	-------	-------	-------	-------	-------	-------	-------------

EC centrifugal fans – RadiPac

backward curved, Ø 280



- **Material:** Support bracket: Steel, painted black
Support plate and inlet ring: Sheet steel, galvanized
Impeller: PP plastic
Rotor: Painted black
Electronics housing: Die-cast aluminium
- **Number of blades:** 6
- **Direction of rotation:** Clockwise viewed toward rotor
- **Degree of protection:** IP 55
- **Insulation class:** "F"
- **Installation position:** Shaft horizontal or rotor on bottom, rotor on top on request
- **Condensation drainage holes:** Rotor side
- **Mode:** Continuous operation (S1)
- **Mounting:** Maintenance-free ball bearings

Nominal data

Type	Motor	Curve	Nominal voltage range	Frequency	Speed ⁽¹⁾	Max. Input power ⁽¹⁾	Max. Input current ⁽¹⁾	Perm. ambient temp.	Weight	Techn. features and connection diagram
Type	Motor	VAC	Hz	rpm	kW	A	°C	kg		
*3G 280	M3G 084-DF	Ⓐ	1~200-277	50/60	2670	0,50	2,30	-25..+45	4,2	P. 118 / RP3)
*3G 280	M3G 084-DF	Ⓑ	1~200-277	50/60	3000	0,75	3,30	-25..+45	4,9	P. 118 / RP3)
*3G 280	M3G 084-FA	Ⓒ	3~380-480	50/60	3400	1,05	1,60	-25..+45	5,4	P. 119 / RP4)

Subject to change

(1) Nominal data at operating point with maximum load and 230 or 400 VAC.

Curves

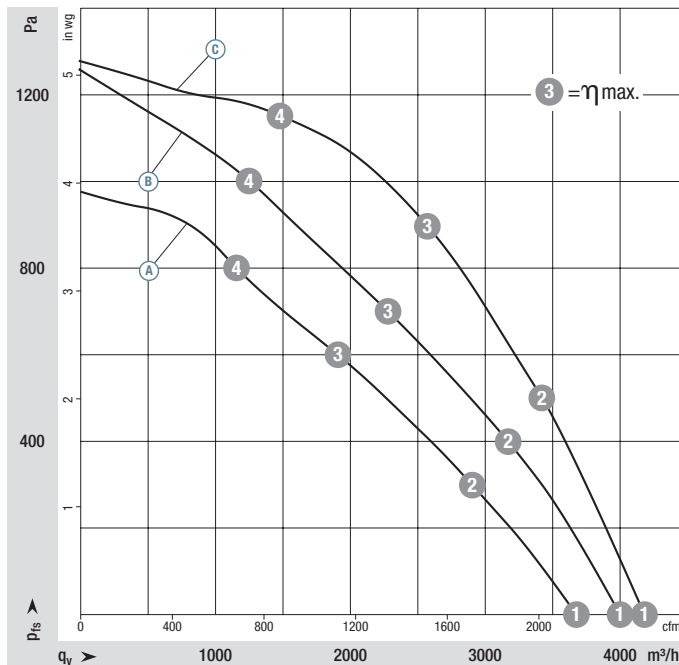

	n rpm	P _{ed} kW	I A	L _{wA} dB(A)
Ⓐ ①	2990	0,50	2,18	85
Ⓐ ②	2785	0,50	2,30	79
Ⓐ ③	2670	0,50	2,30	72
Ⓐ ④	2835	0,50	2,30	77
Ⓑ ①	3260	0,64	2,81	87
Ⓑ ②	3115	0,73	3,18	82
Ⓑ ③	3000	0,75	3,30	77
Ⓑ ④	3180	0,72	3,15	82
Ⓒ ①	3400	0,74	1,17	88
Ⓒ ②	3400	0,96	1,49	83
Ⓒ ③	3400	1,05	1,60	80
Ⓒ ④	3400	0,93	1,43	85

Air performance measured according to: ISO 5801, installation category A, with ebm-papst inlet ring without contact protection. Intake-side sound level: L_{wA} according to ISO 13347, L_{pA} measured at 1 m distance from fan axis. The values given are only applicable under the specified measuring conditions and may differ depending on the installation conditions. In the event of deviation from the standard configuration, the parameters must be checked in installed condition. See Page 126 ff. for detailed information.

- **Technical features:** See connection diagram P. 118 f.
- **EMC:** (A) (B) Interference emission according to EN 61000-6-3
 (C) Interference emission according to EN 61000-6-3, except EN 61000-3-2 for professionally used equipment with a total rated power greater than 1 kW
 (A) (B) (C) Immunity to interference according to EN 61000-6-2
 (A) (B) Circuit feedback according to EN 61000-3-2/3
- **Touch current:** <= 3,5 mA according to IEC 60990 (measuring circuit Fig. 4)
- **Cable exit:** Variable
- **Protection class:** I (with customer connection of protective earth)
- **Conformity with standards:** EN 61800-5-1, CE; (A) (B) EN 60335-1
- **Approvals:** C22.2 Nr.77 + CAN/CSA-E60730-1, UL 1004-7 + 60730
- **Efficiency:** Ecodesign EU regulation EU 327/2011



Weight centrifugal fan



Inlet ring with one pressure tap

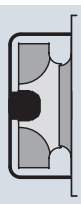

Weight centrifugal module with support bracket

Centrifugal fan	kg	Inlet ring with one pressure tap	Centrifugal module with support bracket	kg
R3G 280-PR03 -H1	4,2	28004-2-4013	K3G 280-PR03 -H2	8,4
R3G 280-PR04 -I1	4,9	28004-2-4013	K3G 280-PR04 -I2	9,1
R3G 280-PS10 -J1	5,4	28004-2-4013	K3G 280-PS10 -J2	9,3

EC centrifugal fans – RadiPac

backward curved, Ø 280



R3G 280-PR03-H1 (Centrifugal fan)



Accessory part: Inlet ring 28004-2-4013
Not included in scope of delivery (k-factor: 77)
Dimensions: see "Accessories" chapter

Max. clearance of screw 16 mm

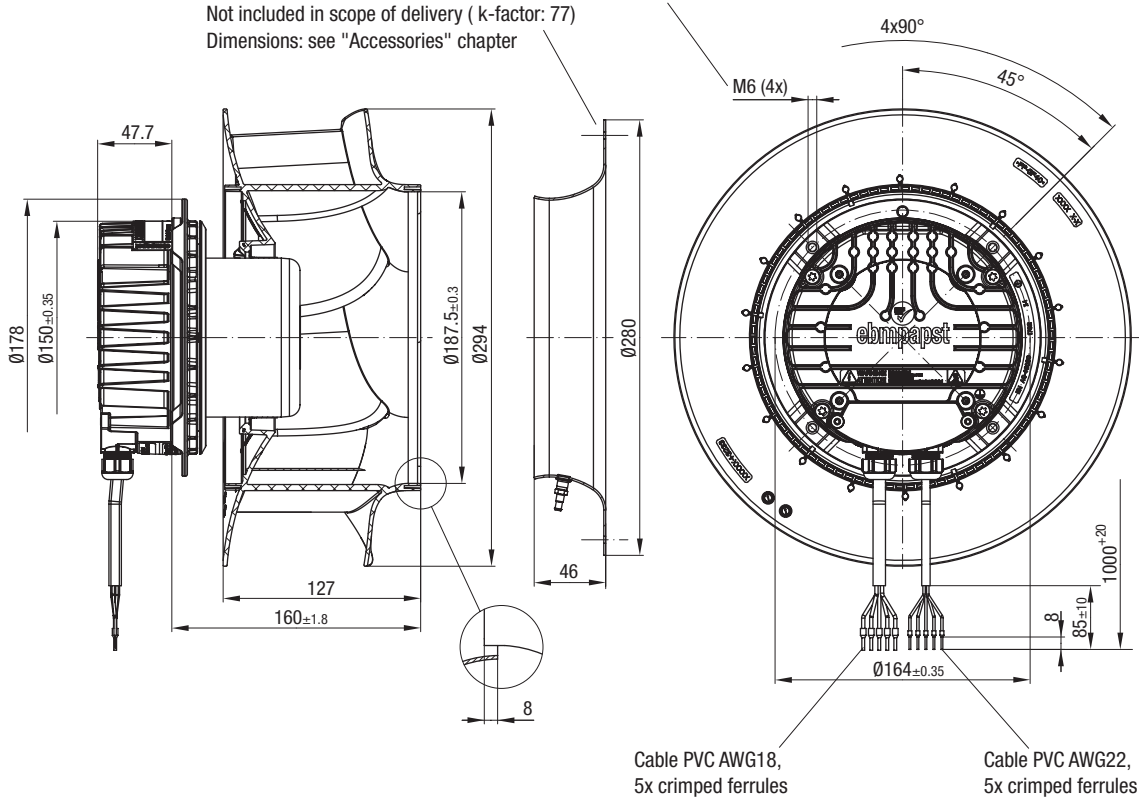

K3G 280-PR03-H2 (Centrifugal module with support bracket)



Attachment for inlet ring and FlowGrid (4x)

Pressure tap (k-factor: 77)

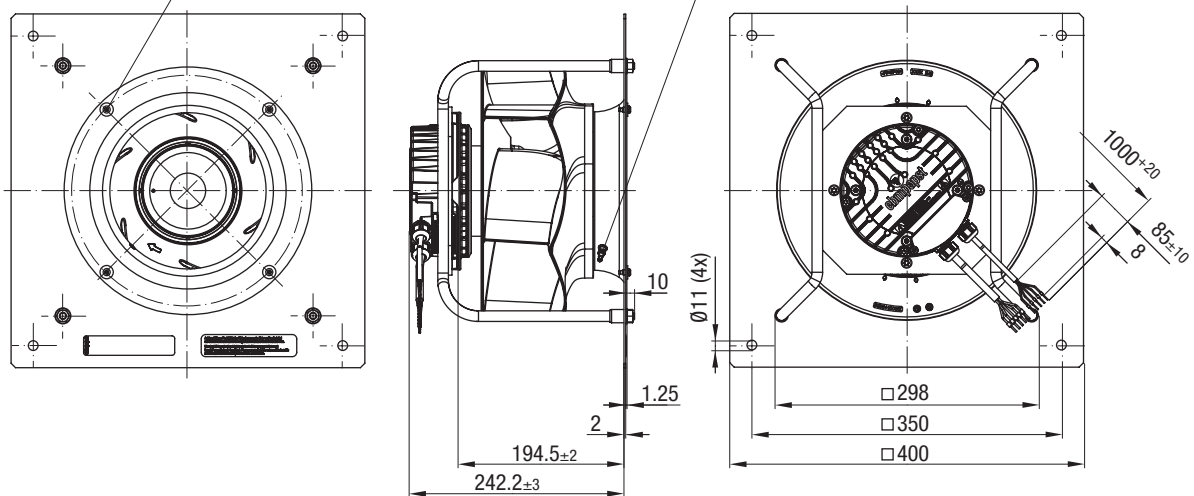

EC centrifugal fans – RadiPac

backward curved, Ø 280



R3G 280-PR04-I1 (Centrifugal fan)



Accessory part: Inlet ring 28004-2-4013
Not included in scope of delivery (k-factor: 77)
Dimensions: see "Accessories" chapter

Max. clearance of screw 16 mm

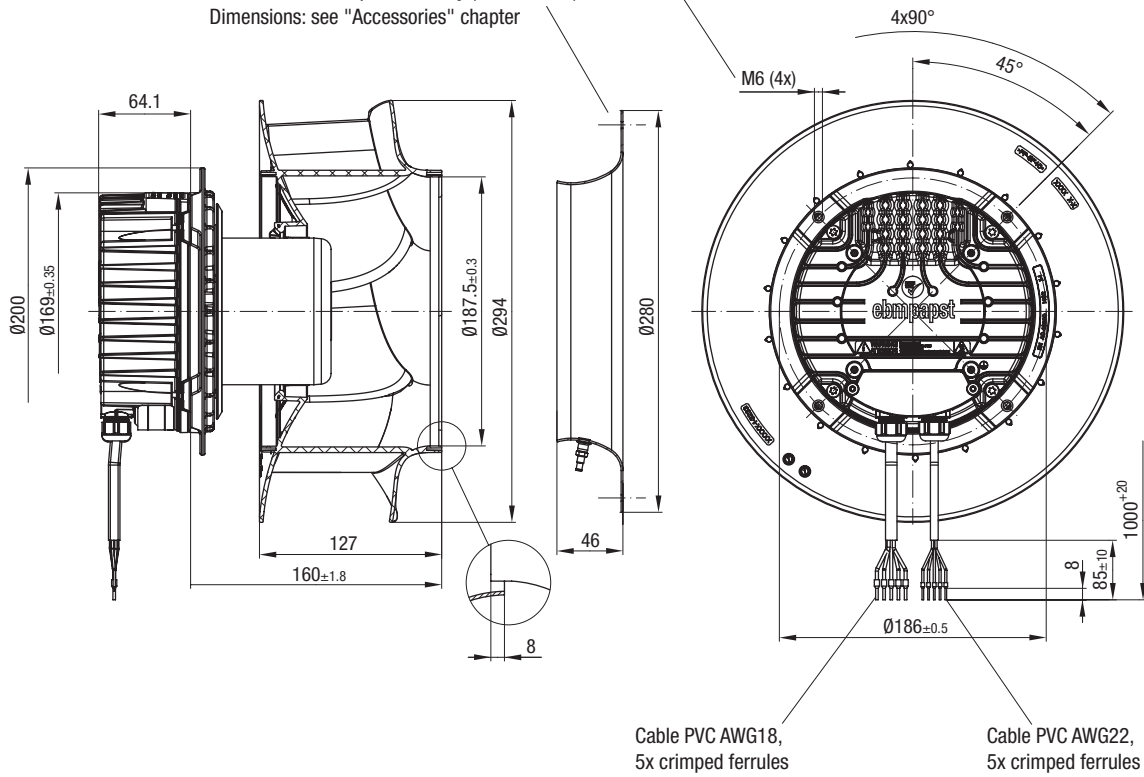

K3G 280-PR04-I2 (Centrifugal module with support bracket)



Attachment for inlet ring and FlowGrid (4x)

Pressure tap (k-factor: 77)

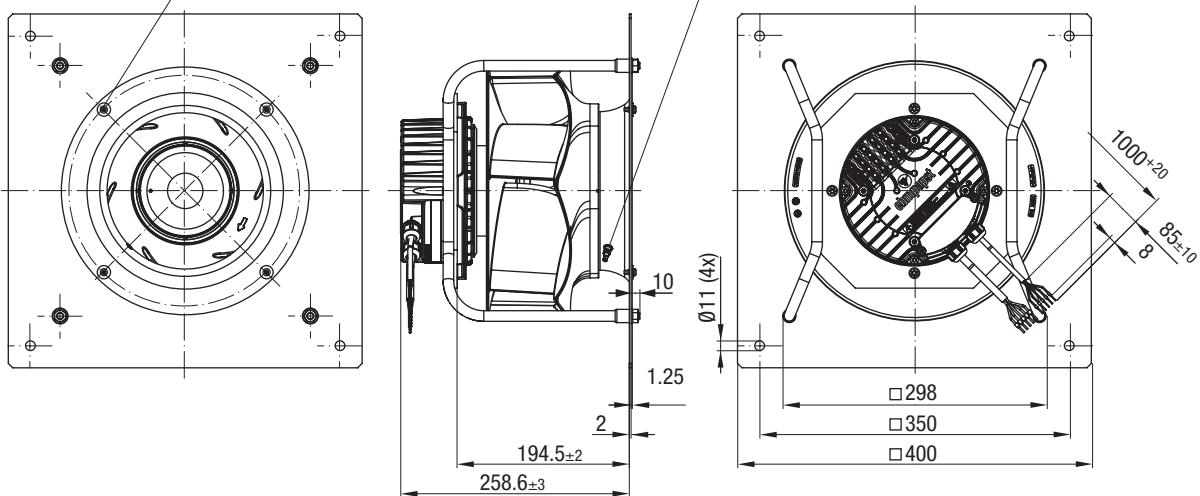

EC centrifugal fans – RadiPac

backward curved, Ø 280



R3G 280-PS10-J1 (Centrifugal fan)



Accessory part: Inlet ring 28004-2-4013
Not included in scope of delivery (k-factor: 77)
Dimensions: see "Accessories" chapter

Max. clearance of screw 16 mm

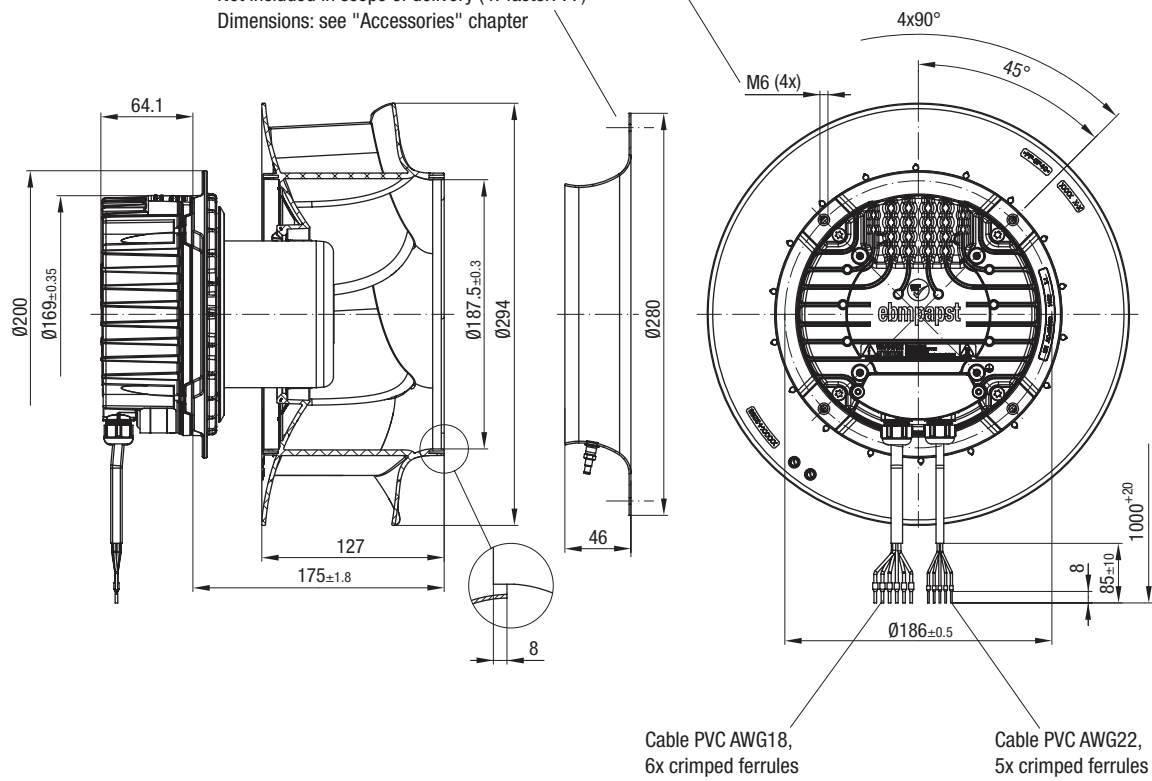

K3G 280-PS10-J2 (Centrifugal module with support bracket)



Attachment for inlet ring and FlowGrid (4x)

Pressure tap (k-factor: 77)

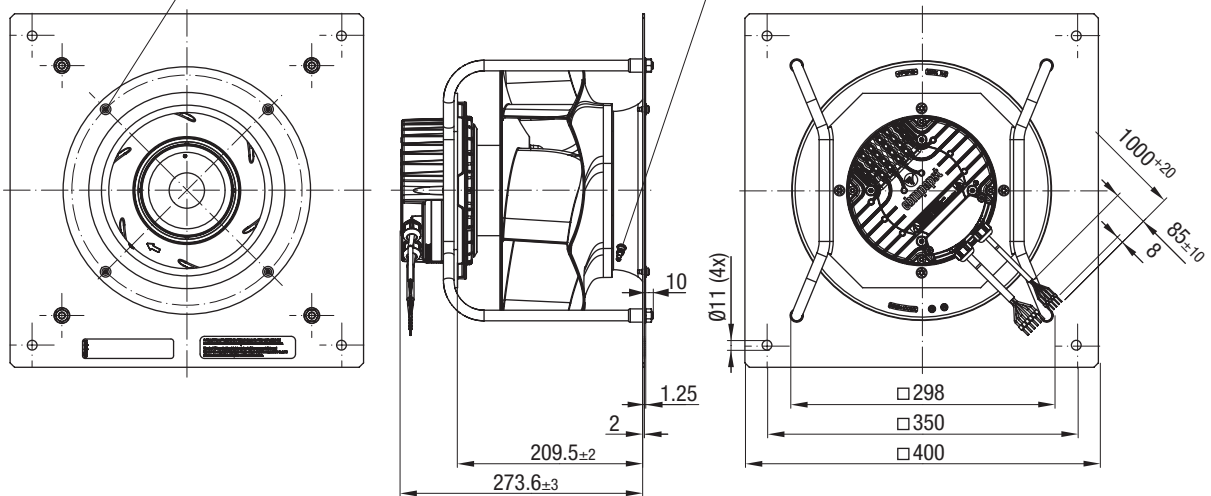

Agents	Technology	ATEX version	Compact version	Short version	Ø 1000	Ø 800	Ø 710	Ø 630	Ø 560	Ø 500	Ø 450	Ø 400	Ø 355	Ø 310	Ø 280	Ø 250	Information
--------	------------	--------------	-----------------	---------------	--------	-------	-------	-------	-------	-------	-------	-------	-------	-------	-------	-------	-------------

EC centrifugal fans – RadiPac

backward curved, Ø 310

- **Material:** Support bracket: Steel, painted black
Support plate and inlet ring: Sheet steel, galvanized
Impeller: Sheet aluminium
Rotor: Painted black
Electronics housing: Die-cast aluminium
- **Number of blades:** 5
- **Direction of rotation:** Clockwise viewed toward rotor
- **Degree of protection:** (A) IP 55; (B) (C) IP 54
- **Insulation class:** (A) "F"; (B) (C) "B"
- **Installation position:** Shaft horizontal or rotor on bottom, rotor on top on request
- **Condensation drainage holes:** Rotor side
- **Mode:** Continuous operation (S1)
- **Mounting:** Maintenance-free ball bearings



Nominal data

Type	Motor	Curve	Nominal voltage range	Frequency	Speed ⁽¹⁾	Max. Input power ⁽¹⁾	Max. Input current ⁽¹⁾	Perm. ambient temp.	Weight	Techn. features and connection diagram
Type	Motor	VAC	Hz	rpm	kW	A	°C	kg		
*3G 310	M3G 084-GF	(A) 3~380-480	50/60	3010	1,23	1,90	-25..+40	7,0	P. 119 / RP4)	
*3G 310	M3G 112-GA	(B) 3~380-480	50/60	3410	1,80	2,80	-25..+50	10,9	P. 116 / RP1)	
*3G 310	M3G 112-GA	(C) 3~380-480	50/60	4000	2,95	4,60	-25..+40	10,9	P. 116 / RP1)	

Subject to change

(1) Nominal data at operating point with maximum load and 400 VAC.

Curves

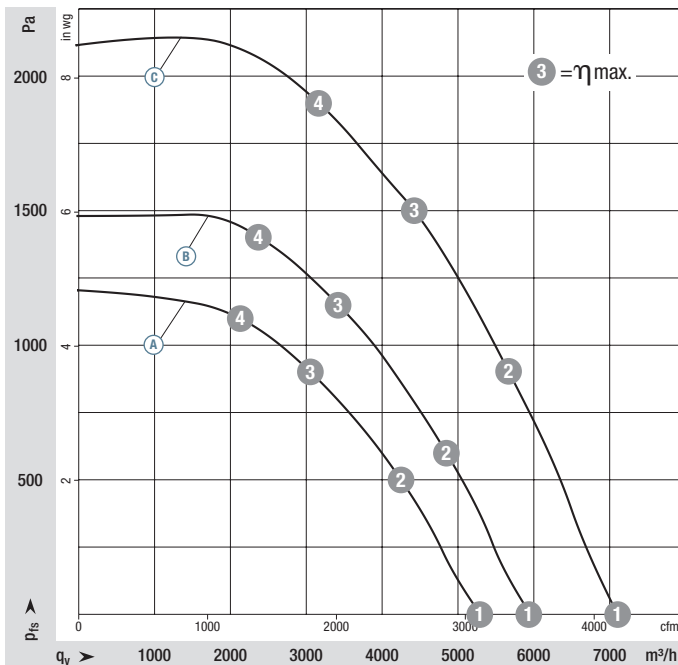

	n rpm	P _{ed} kW	I A	L _{wA} dB(A)
(A) 1	3010	0,67	1,06	92
(A) 2	3010	1,05	1,61	84
(A) 3	3010	1,23	1,90	78
(A) 4	3010	1,19	1,82	85
(B) 1	3410	1,05	1,68	93
(B) 2	3410	1,54	2,40	86
(B) 3	3410	1,80	2,80	83
(B) 4	3410	1,75	2,69	87
(C) 1	4000	1,71	2,66	102
(C) 2	4000	2,61	4,03	92
(C) 3	4000	2,94	4,53	89
(C) 4	4000	2,95	4,60	92

Air performance measured according to: ISO 5801, installation category A, with ebm-papst inlet ring without contact protection. Intake-side sound level: L_{wA} according to ISO 13347, L_{pA} measured at 1 m distance from fan axis. The values given are only applicable under the specified measuring conditions and may differ depending on the installation conditions. In the event of deviation from the standard configuration, the parameters must be checked in installed condition. See Page 126 ff. for detailed information.

- **Technical features:** See connection diagram P. 116 ff.
- **EMC:** Interference emission according to EN 61000-6-3, except EN 61000-3-2 for professionally used equipment with a total rated power greater than 1 kW
Immunity to interference according to EN 61000-6-2
- **Touch current:** <= 3,5 mA according to IEC 60990 (measuring circuit Fig. 4)
- **Terminal box design:** electrical connection via terminal strip
- **Protection class:** I (with customer connection of protective earth)
- **Conformity with standards:** EN 61800-5-1, CE
- **Approvals:** C22.2 Nr.77 + CAN/CSA-E60730-1, UL 1004-7 + 60730
- **Efficiency:** Ecodesign EU regulation EU 327/2011



Weight centrifugal fan



Weight centrifugal module with support bracket

Centrifugal fan	kg	Inlet ring with one pressure tap	Centrifugal module with support bracket	kg
R3G 310-PT08 -J1	7,0	31475-2-4013	K3G 310-PT08 -J2	15,5
R3G 310-PH38 -01	10,9	31475-2-4013	K3G 310-PH38 -02	18,0
R3G 310-PH58 -01	10,9	31475-2-4013	K3G 310-PH58 -02	18,0

EC centrifugal fans – RadiPac

backward curved, Ø 310

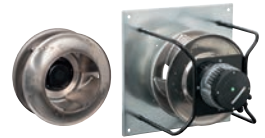

R3G 310-PT08-J1 (Centrifugal fan)

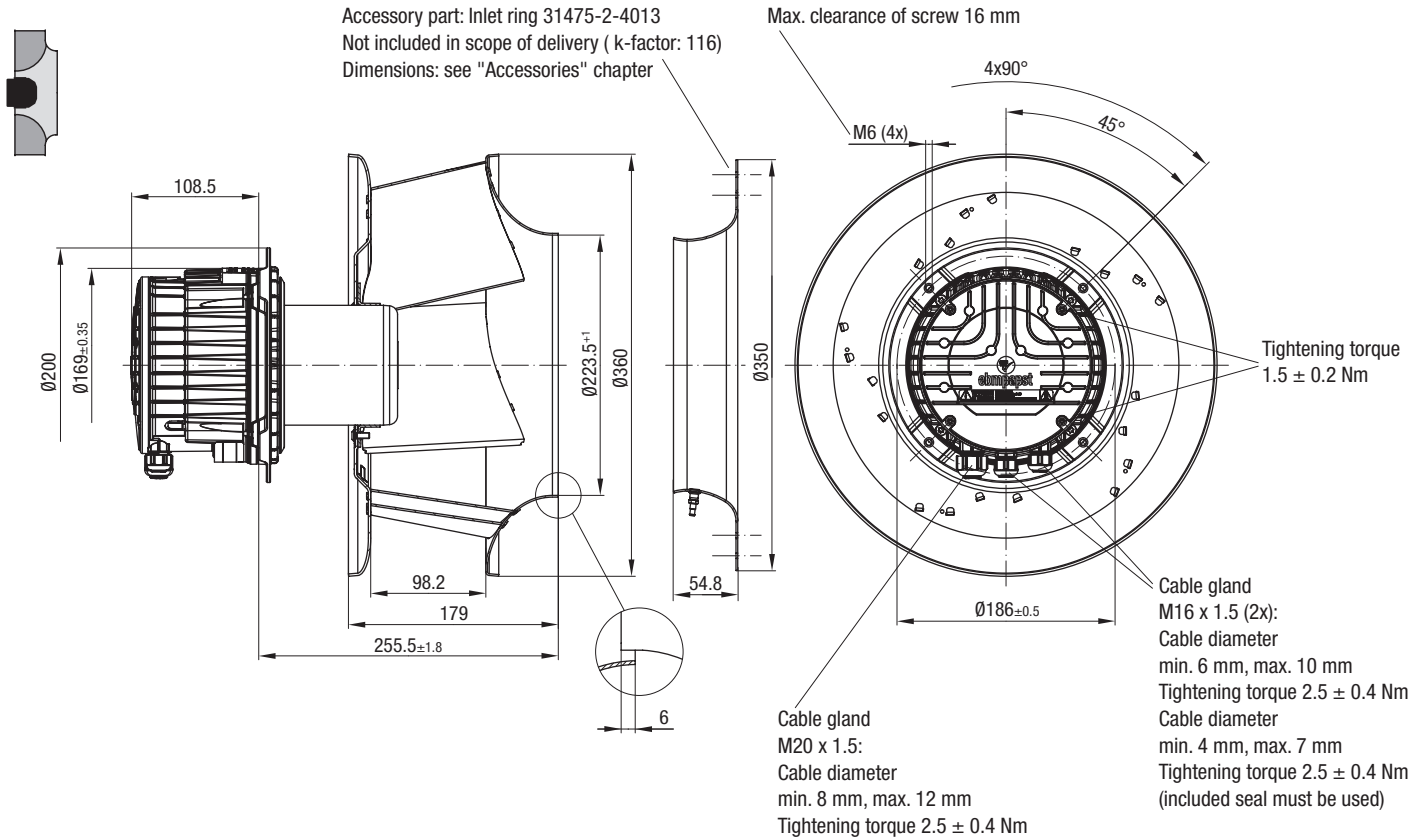

K3G 310-PT08-J2 (Centrifugal module with support bracket)

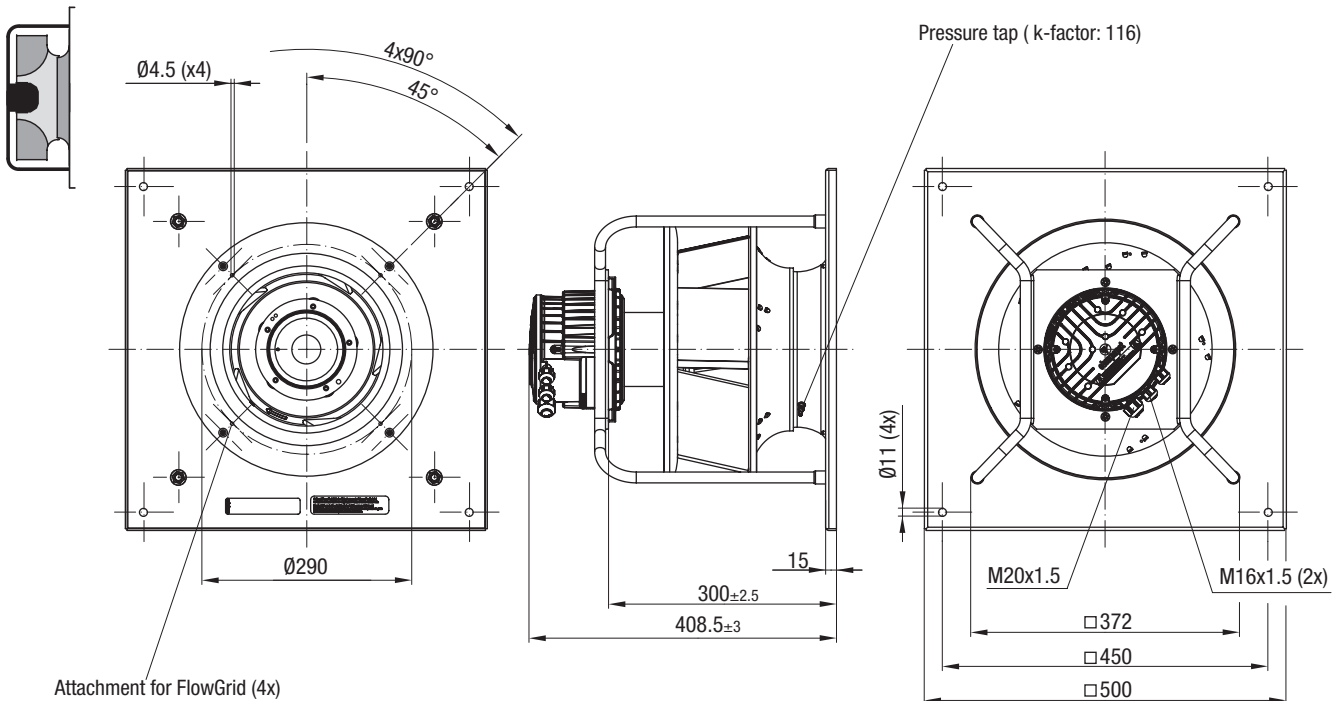

EC centrifugal fans – RadiPac

backward curved, Ø 310



R3G 310-PH38-01 (Centrifugal fan)

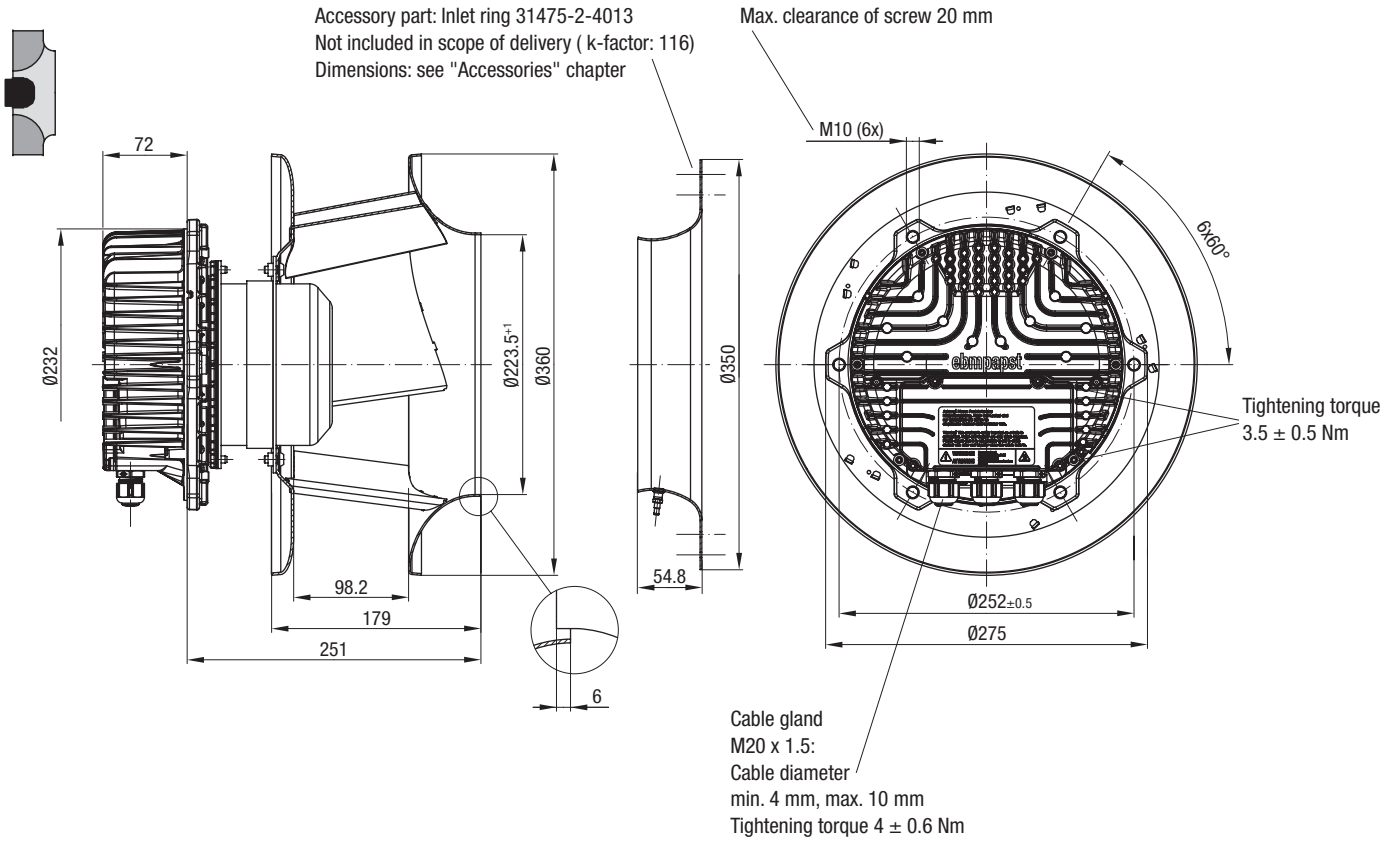

K3G 310-PH38-02 (Centrifugal module with support bracket)

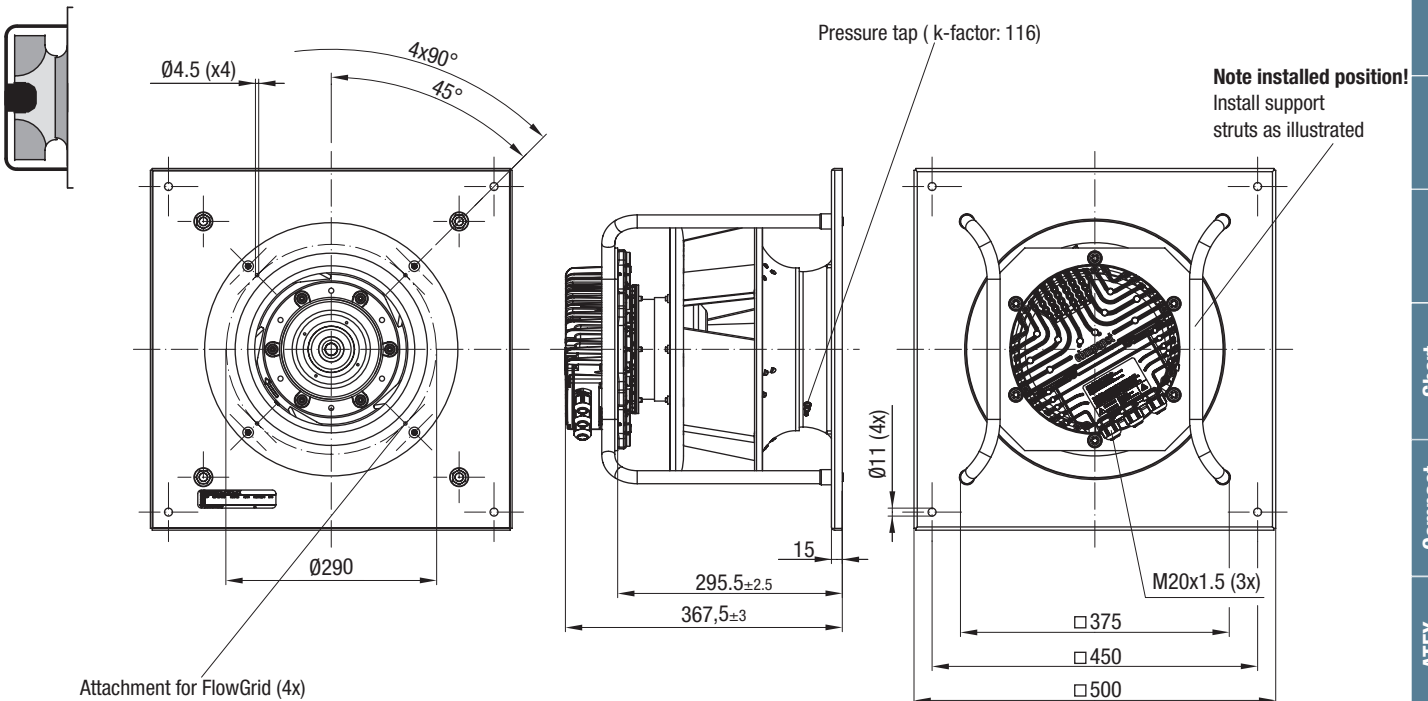

EC centrifugal fans – RadiPac

backward curved, Ø 310



R3G 310-PH58-01 (Centrifugal fan)

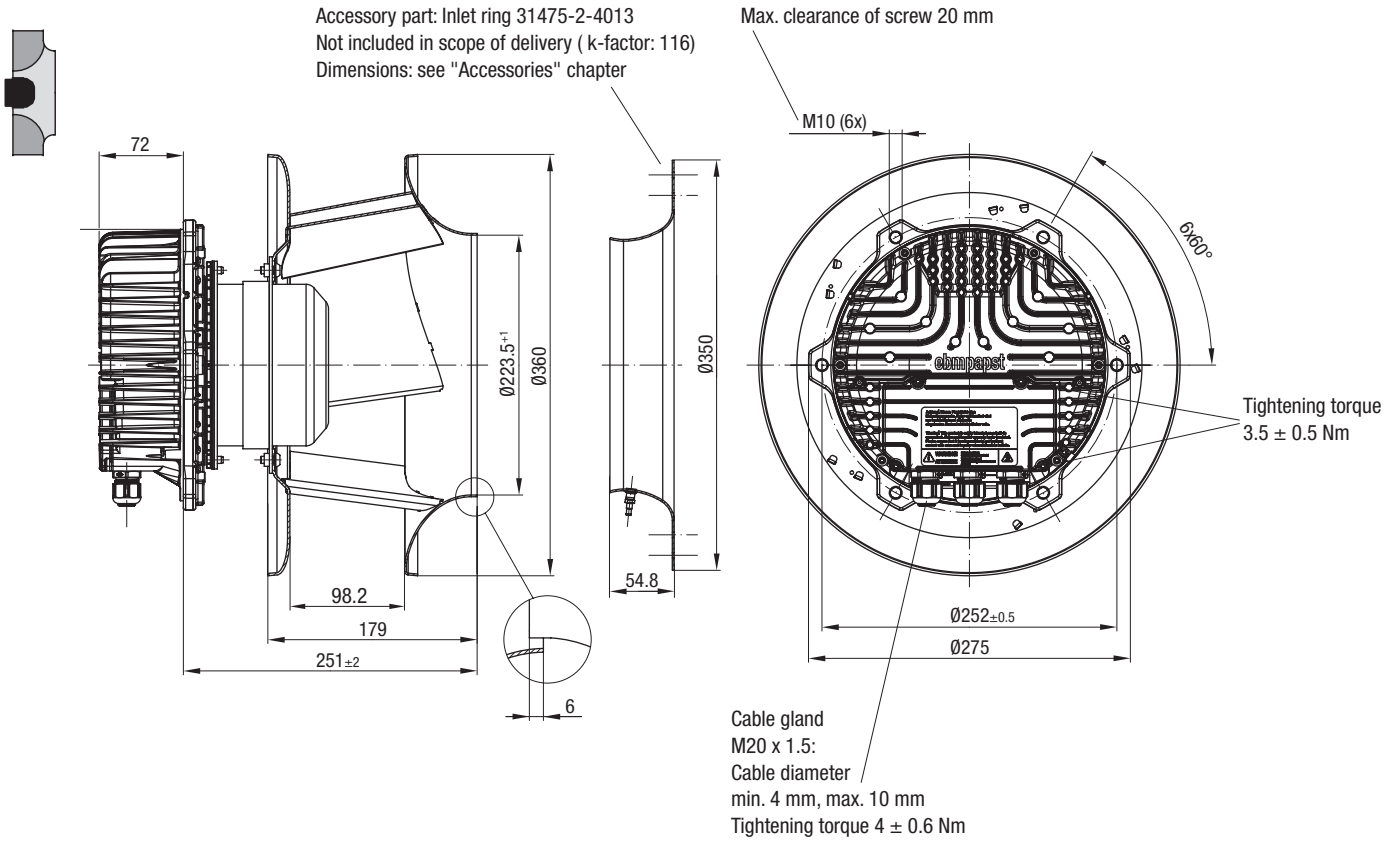

K3G 310-PH58-02 (Centrifugal module with support bracket)

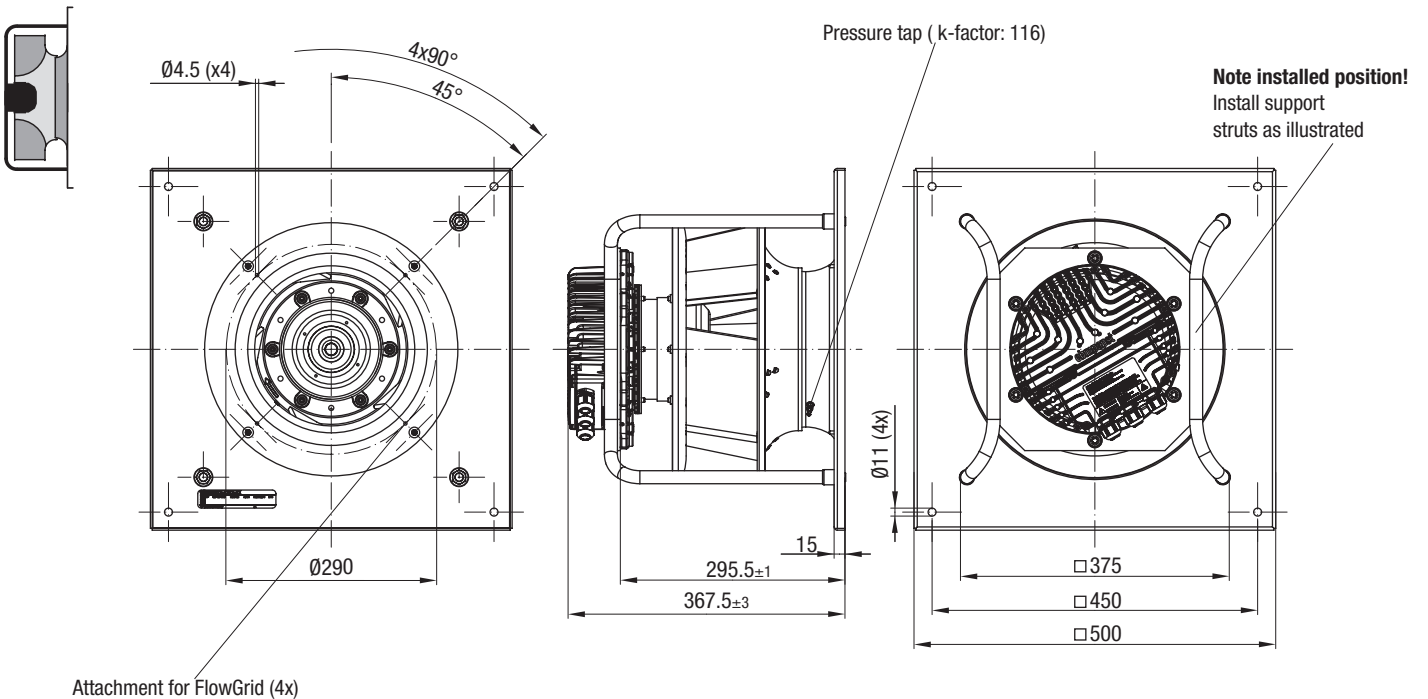

Agents	Technology	ATEX version	Compact version	Short version	Ø 1000	Ø 800	Ø 710	Ø 630	Ø 560	Ø 500	Ø 450	Ø 400	Ø 355	Ø 310	Ø 280	Ø 250	Information
--------	------------	--------------	-----------------	---------------	--------	-------	-------	-------	-------	-------	-------	-------	-------	-------	-------	-------	-------------

EC centrifugal fans – RadiPac

backward curved, Ø 355

- **Material:** Support bracket: Steel, painted black
Support plate and inlet ring: Sheet steel, galvanized
Impeller: Sheet aluminium
Rotor: Painted black
Electronics housing: Die-cast aluminium
- **Number of blades:** 5
- **Direction of rotation:** Clockwise viewed toward rotor
- **Degree of protection:** (A) IP 55; (B) (C) IP 54
- **Insulation class:** (A) "F"; (B) (C) "B"
- **Installation position:** Shaft horizontal or rotor on bottom, rotor on top on request
- **Condensation drainage holes:** Rotor side
- **Mode:** Continuous operation (S1)
- **Mounting:** Maintenance-free ball bearings



Nominal data

Type	Motor	Curve	Nominal voltage range	Frequency	Speed ⁽¹⁾	Max. Input power ⁽¹⁾	Max. Input current ⁽¹⁾	Perm. ambient temp.	Weight	Techn. features and connection diagram
Type	Motor	VAC	Hz	rpm	kW	A	°C	kg		
*3G 355	M3G 112-EA	(A) 3~380-480	50/60	2400	1,10	1,70	-25..+60	8,7	P. 119 / RP4)	
*3G 355	M3G 112-GA	(B) 3~380-480	50/60	2870	1,90	3,00	-25..+55	13,0	P. 116 / RP1)	
*3G 355	M3G 112-IA	(C) 3~380-480	50/60	3230	2,68	4,10	-25..+40	15,0	P. 116 / RP1)	

Subject to change

(1) Nominal data at operating point with maximum load and 400 VAC.

Curves

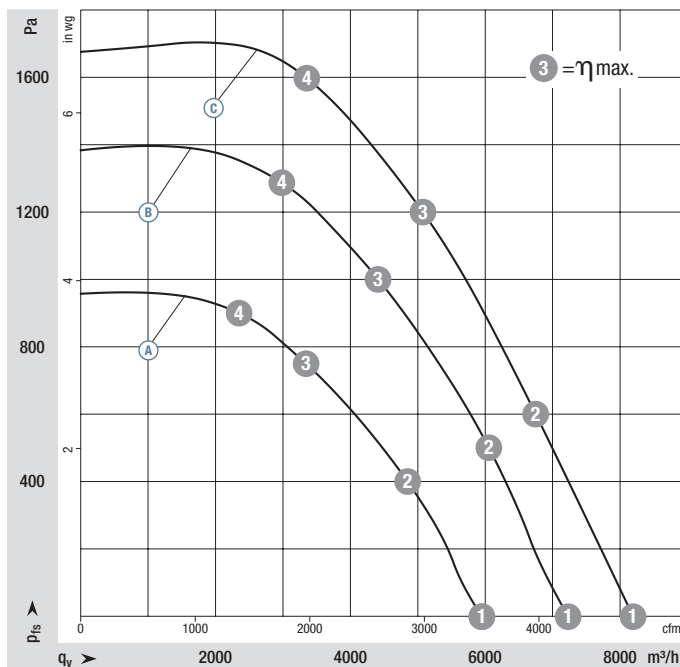

	n rpm	P _{ed} kW	I A	L _{wA} dB(A)
(A) 1	2400	0,62	0,98	87
(A) 2	2400	0,97	1,49	78
(A) 3	2400	1,10	1,70	76
(A) 4	2400	1,07	1,65	80
(B) 1	2870	1,05	1,69	92
(B) 2	2870	1,58	2,46	85
(B) 3	2870	1,90	3,00	81
(B) 4	2870	1,89	2,92	86
(C) 1	3230	1,48	2,30	93
(C) 2	3230	2,16	3,32	87
(C) 3	3230	2,68	4,10	83
(C) 4	3230	2,56	3,94	87

Air performance measured according to: ISO 5801, installation category A, with ebm-papst inlet ring without contact protection. Intake-side sound level: L_{wA} according to ISO 13347, L_{pA} measured at 1 m distance from fan axis. The values given are only applicable under the specified measuring conditions and may differ depending on the installation conditions. In the event of deviation from the standard configuration, the parameters must be checked in installed condition. See Page 126 ff. for detailed information.

- **Technical features:** See connection diagram P. 116 ff.
- **EMC:** Interference emission according to EN 61000-6-3, except EN 61000-3-2 for professionally used equipment with a total rated power greater than 1 kW
Immunity to interference according to EN 61000-6-2
- **Touch current:** $\leq 3,5$ mA according to IEC 60990 (measuring circuit Fig. 4)
- **Terminal box design:** electrical connection via terminal strip
- **Protection class:** I (with customer connection of protective earth)
- **Conformity with standards:** EN 61800-5-1, CE
- **Approvals:** C22.2 Nr.77 + CAN/CSA-E60730-1, UL 1004-7 + 60730
- **Efficiency:** Ecodesign EU regulation EU 327/2011



Weight centrifugal fan

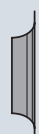

Inlet ring with one pressure tap



Weight centrifugal module with support bracket

Centrifugal fan	kg	Inlet ring with one pressure tap	Centrifugal module with support bracket	kg
R3G 355-PJ75 -01	8,7	35675-2-4013	K3G 355-PJ75 -01	16,4
R3G 355-PH49 -01	13,0	35675-2-4013	K3G 355-PH49 -02	23,0
R3G 355-PI93 -01	15,0	35675-2-4013	K3G 355-PI93 -02	26,0

EC centrifugal fans – RadiPac

backward curved, Ø 355

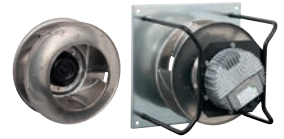

R3G 355-PJ75-01 (Centrifugal fan)



Accessory part: Inlet ring 35675-2-4013
Not included in scope of delivery (k-factor: 148)
Dimensions: see "Accessories" chapter

Max. clearance of screw 20 mm

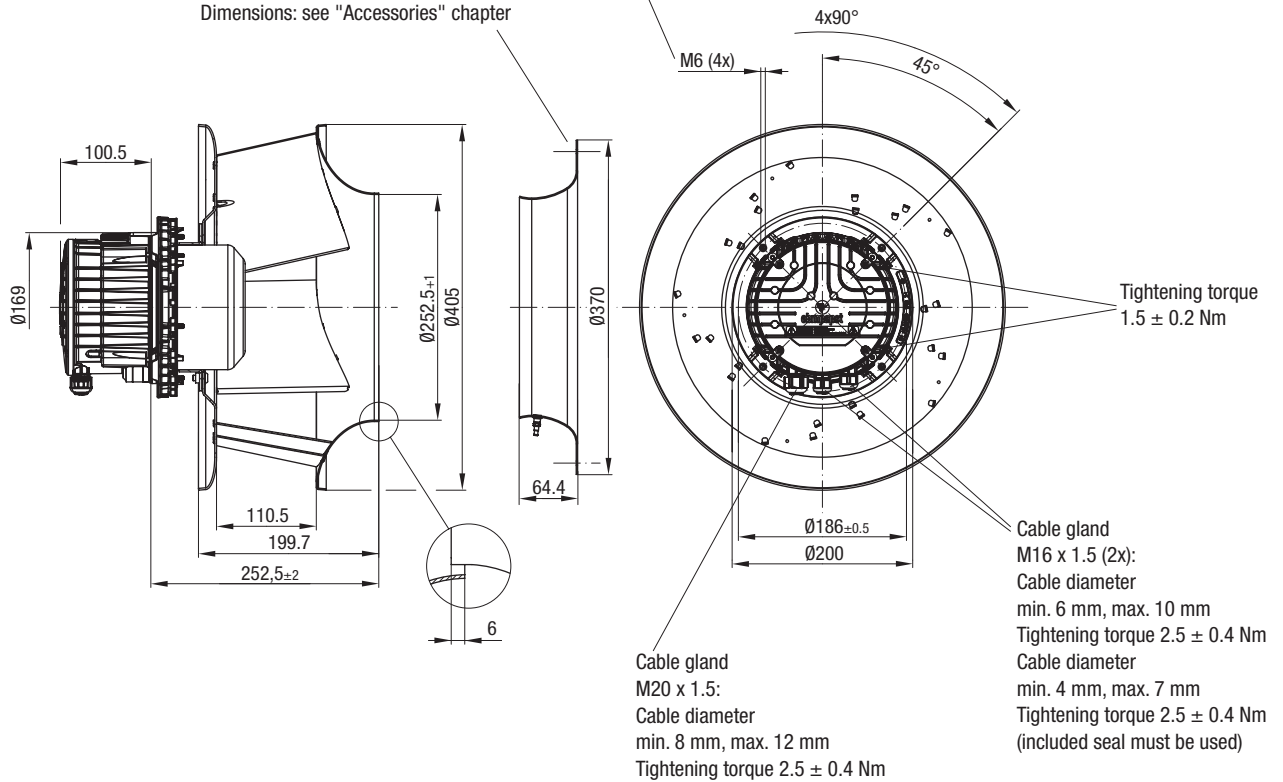

K3G 355-PJ75-01 (Centrifugal module with support bracket)

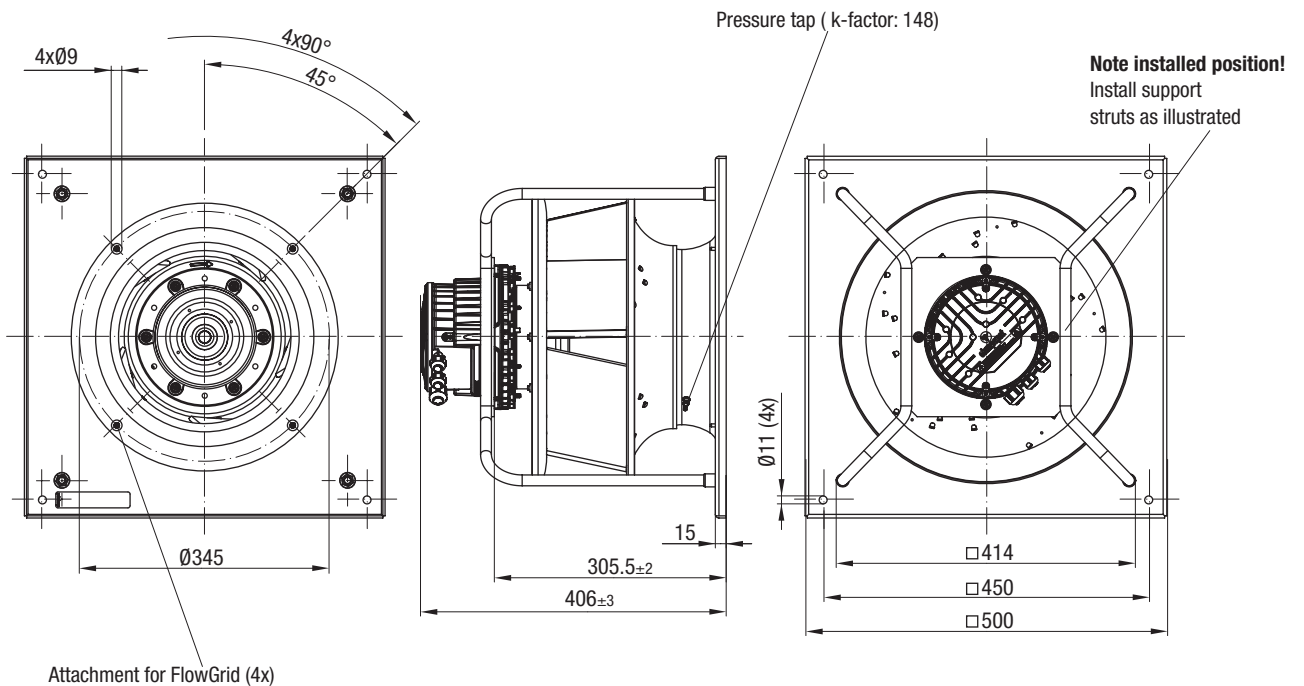

EC centrifugal fans – RadiPac

backward curved, Ø 355

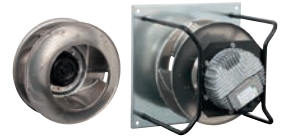

Information

Ø 250

Ø 280

Ø 310

Ø 355

Ø 400

Ø 450

Ø 500

Ø 560

Ø 630

Ø 710

Ø 800

Ø 1000

Short version

Compact version

ATEX version

Technology

Agents

33

2017-07

R3G 355-PH49-01 (Centrifugal fan)



Accessory part: Inlet ring 35675-2-4013
Not included in scope of delivery (k-factor: 148)
Dimensions: see "Accessories" chapter

Max. clearance of screw 20 mm

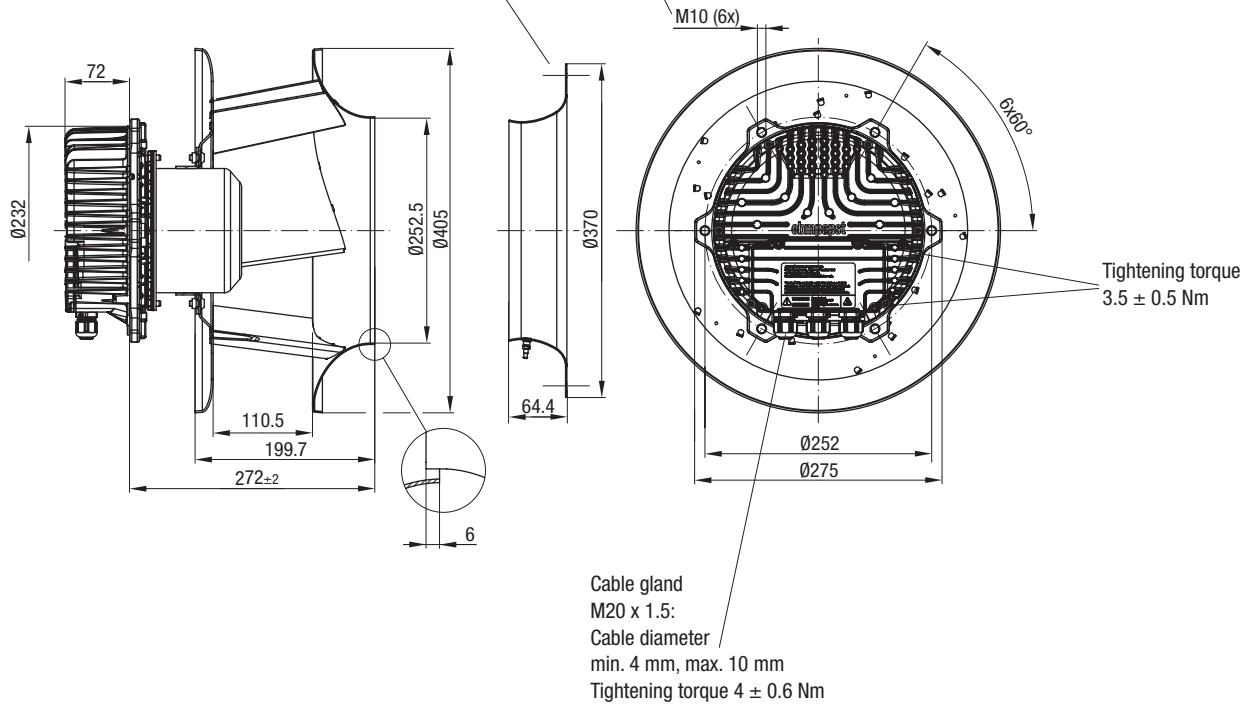

K3G 355-PH49-02 (Centrifugal module with support bracket)

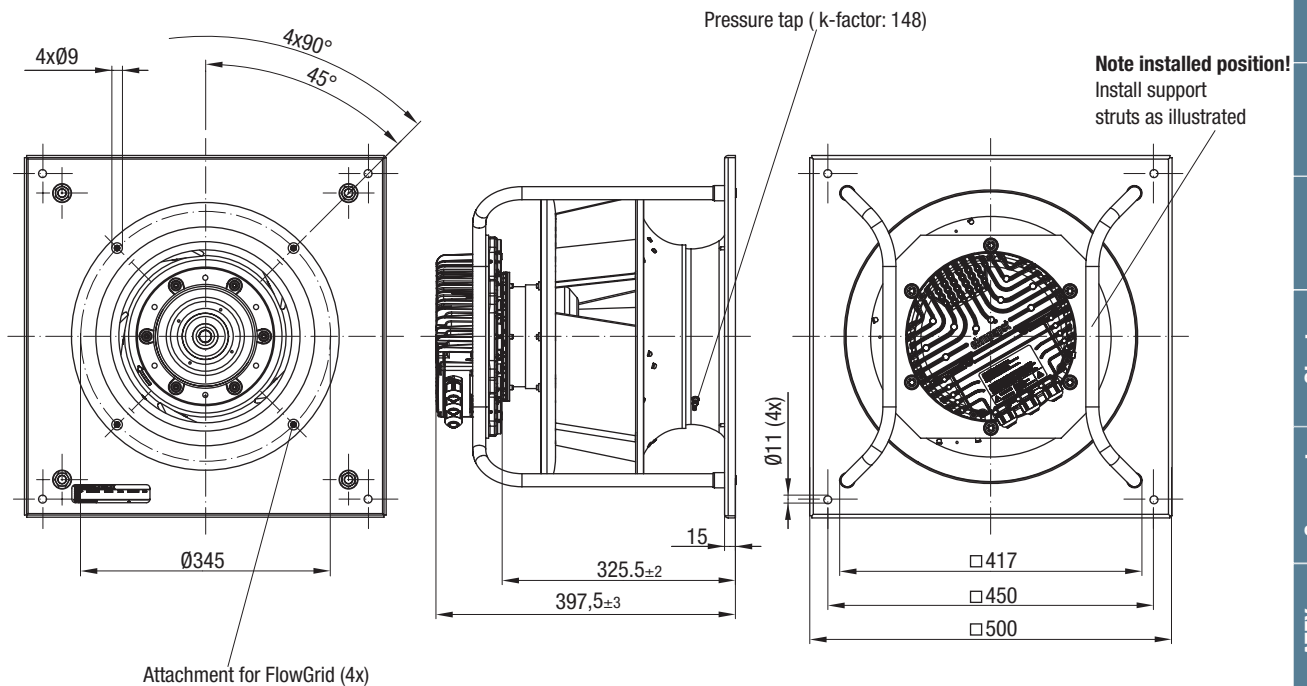

EC centrifugal fans – RadiPac

backward curved, Ø 355

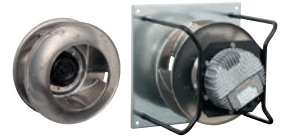

R3G 355-PI93-01 (Centrifugal fan)



Accessory part: Inlet ring 35675-2-4013
Not included in scope of delivery (k-factor: 148)
Dimensions: see "Accessories" chapter

Max. clearance of screw 20 mm

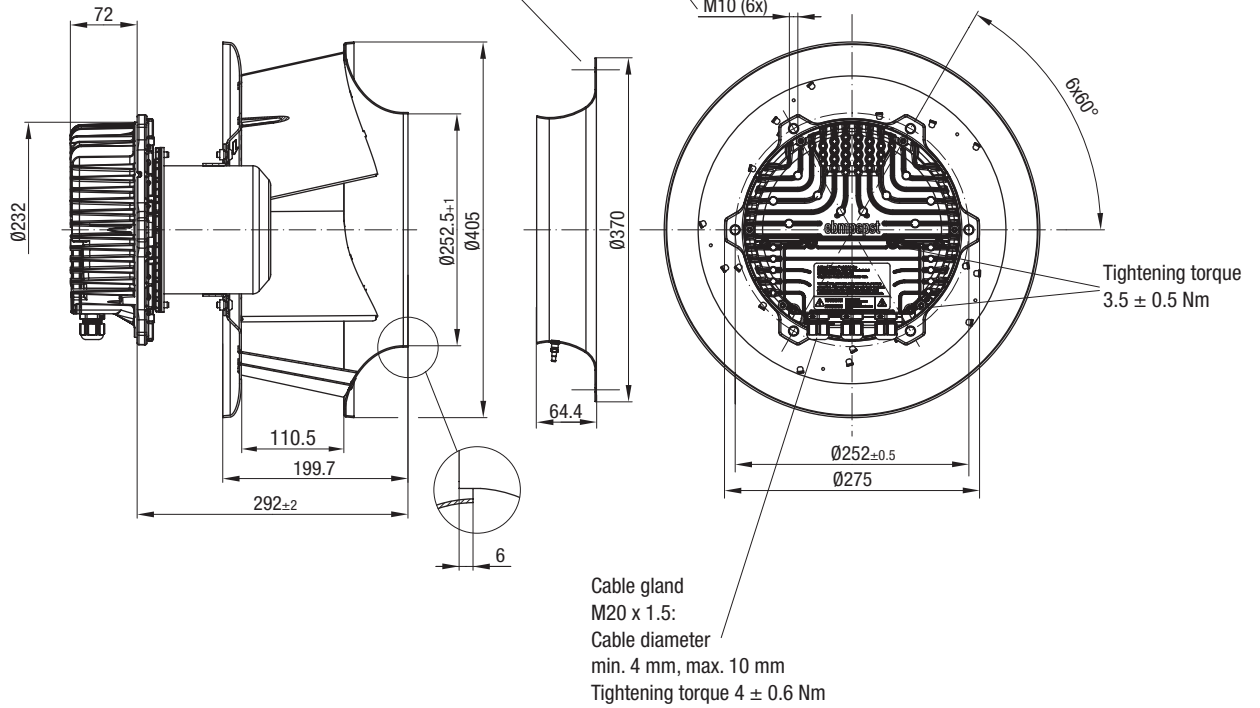

K3G 355-PI93-02 (Centrifugal module with support bracket)

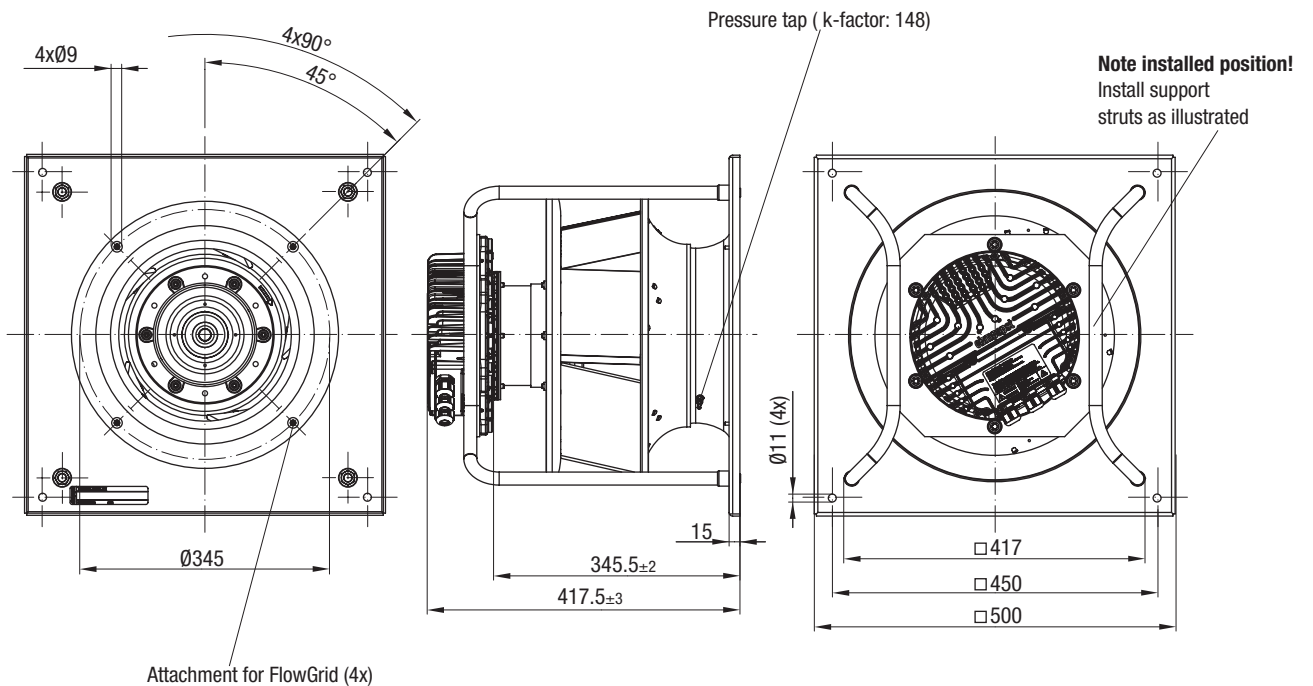

Agents	Technology	ATEX version	Compact version	Short version	Ø 1000	Ø 800	Ø 710	Ø 630	Ø 560	Ø 500	Ø 450	Ø 400	Ø 355	Ø 310	Ø 280	Ø 250	Information
--------	------------	--------------	-----------------	---------------	--------	-------	-------	-------	-------	-------	-------	-------	-------	-------	-------	-------	-------------

EC centrifugal fans – RadiPac

backward curved, Ø 400



- **Material:** Support bracket: Steel, painted black
Support plate and inlet ring: Sheet steel, galvanized
Impeller: Sheet aluminium
Rotor: Painted black
Electronics housing: Die-cast aluminium
- **Number of blades:** 5
- **Direction of rotation:** Clockwise viewed toward rotor
- **Degree of protection:** Ⓐ IP 54; Ⓑ IP 55
- **Insulation class:** Ⓐ "B"; Ⓑ "F"
- **Installation position:** Shaft horizontal or rotor on bottom, rotor on top on request
- **Condensation drainage holes:** Rotor side
- **Mode:** Continuous operation (S1)
- **Mounting:** Maintenance-free ball bearings

Nominal data

Type	Motor	Curve	Nominal voltage range	Frequency	Speed ⁽¹⁾	Max. Input power ⁽¹⁾	Max. Input current ⁽¹⁾	Perm. ambient temp.	Weight	Techn. features and connection diagram
Type	Motor	VAC	Hz	rpm	kW	A	°C	kg		
*3G 400	M3G 112-IA	Ⓐ 3~380-480	50/60	2450	2,50	3,80	-25..+40	14,6	P. 116 / RP1)	
*3G 400	M3G 150-FF	Ⓑ 3~380-480	50/60	2750	3,35	5,20	-25..+60	20,3	P. 117 / RP2)	

Subject to change

(1) Nominal data at operating point with maximum load and 400 VAC.

Curves

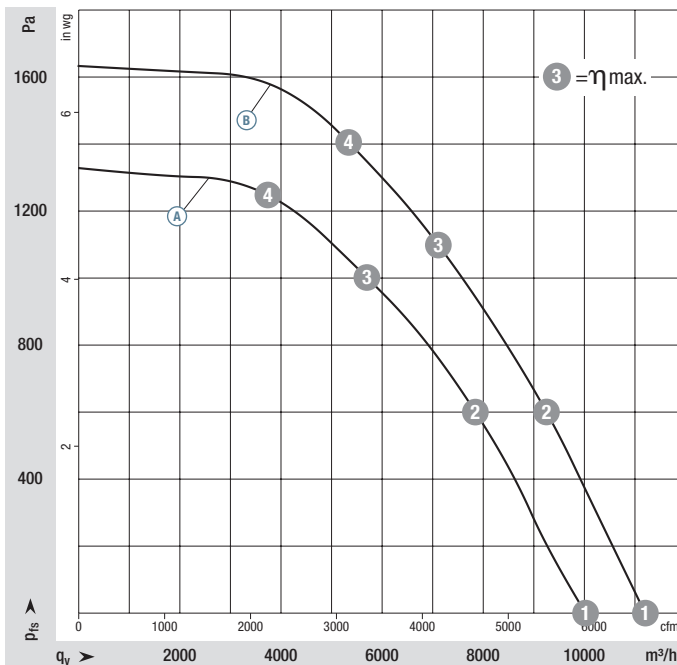

	n rpm	P _{ed} kW	I A	L _{wA} dB(A)
Ⓐ ①	2450	1,32	2,07	96
Ⓐ ②	2450	2,21	3,38	85
Ⓐ ③	2450	2,50	3,80	82
Ⓐ ④	2450	2,34	3,57	86
Ⓑ ①	2750	1,85	2,90	100
Ⓑ ②	2750	2,83	4,35	90
Ⓑ ③	2750	3,29	5,04	85
Ⓑ ④	2750	3,35	5,20	86

Air performance measured according to: ISO 5801, installation category A, with ebm-papst inlet ring without contact protection. Intake-side sound level: L_{wA} according to ISO 13347, L_{pA} measured at 1 m distance from fan axis. The values given are only applicable under the specified measuring conditions and may differ depending on the installation conditions. In the event of deviation from the standard configuration, the parameters must be checked in installed condition. See Page 126 ff. for detailed information.

- **Technical features:** See connection diagram P. 116 f.
- **EMC:** Ⓐ Interference emission according to EN 61000-6-3, except EN 61000-3-2 for professionally used equipment with a total rated power greater than 1 kW
Immunity to interference according to EN 61000-6-2
- **Touch current:** <= 3,5 mA according to IEC 60990 (measuring circuit Fig. 4)
- **Terminal box design:** electrical connection via terminal strip
- **Protection class:** I (with customer connection of protective earth)
- **Conformity with standards:** EN 61800-5-1, CE
- **Approvals:** Ⓐ C22.2 Nr.77 + CAN/CSA-E60730-1, UL 1004-7 + 60730
Ⓑ EAC
- **Efficiency:** Ecodesign EU regulation EU 327/2011



Weight centrifugal fan

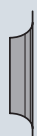

Inlet ring with one pressure tap



Weight centrifugal module with support bracket

Centrifugal fan	kg	Inlet ring with one pressure tap	Centrifugal module with support bracket	kg
R3G 400-PI92 -01	14,6	40078-2-4013	K3G 400-PI92 -02	26,0
R3G 400-PA27 -71	20,3	40078-2-4013	K3G 400-PA27 -71	32,0

EC centrifugal fans – RadiPac

backward curved, Ø 400



R3G 400-PI92-01 (Centrifugal fan)

Accessory part: Inlet ring 40078-2-4013
Not included in scope of delivery (k-factor: 188)
Dimensions: see "Accessories" chapter

Max. clearance of screw 20 mm

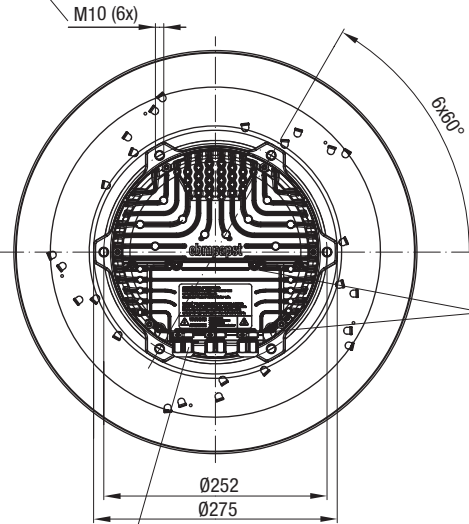
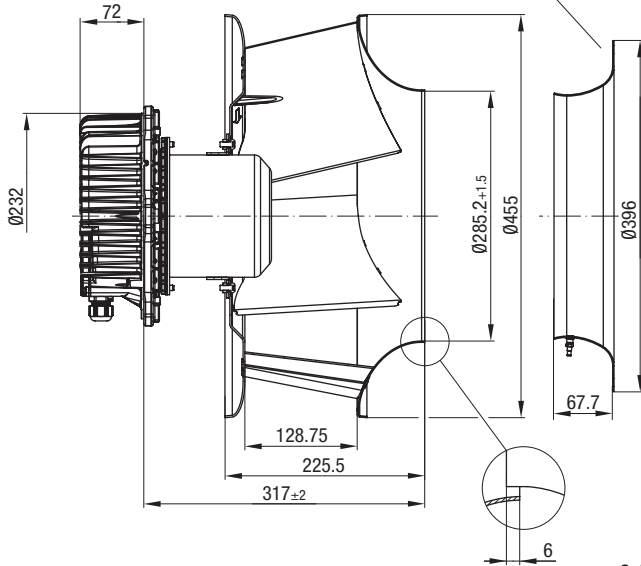

Cable gland
M20 x 1.5:
Cable diameter
min. 4 mm, max. 10 mm
Tightening torque 4 ± 0.6 Nm

K3G 400-PI92-02 (Centrifugal module with support bracket)

Pressure tap (k-factor: 188)

Note installed position!
Install support
struts as illustrated

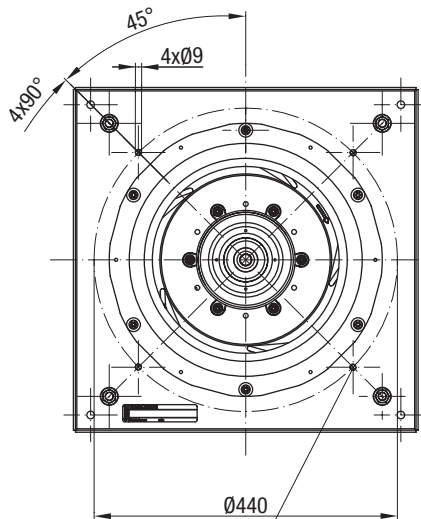
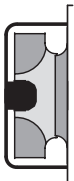

Attachment for FlowGrid (4x)

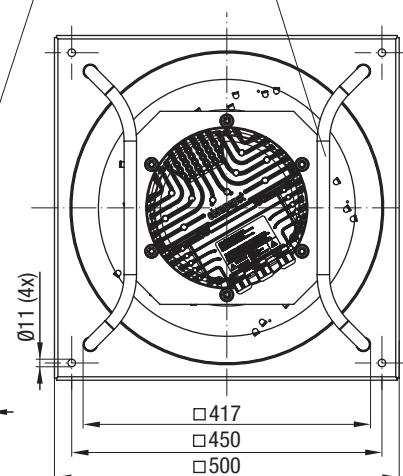
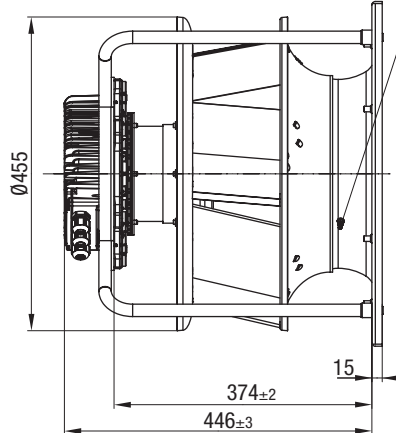

EC centrifugal fans – RadiPac

backward curved, Ø 400



R3G 400-PA27-71 (Centrifugal fan)

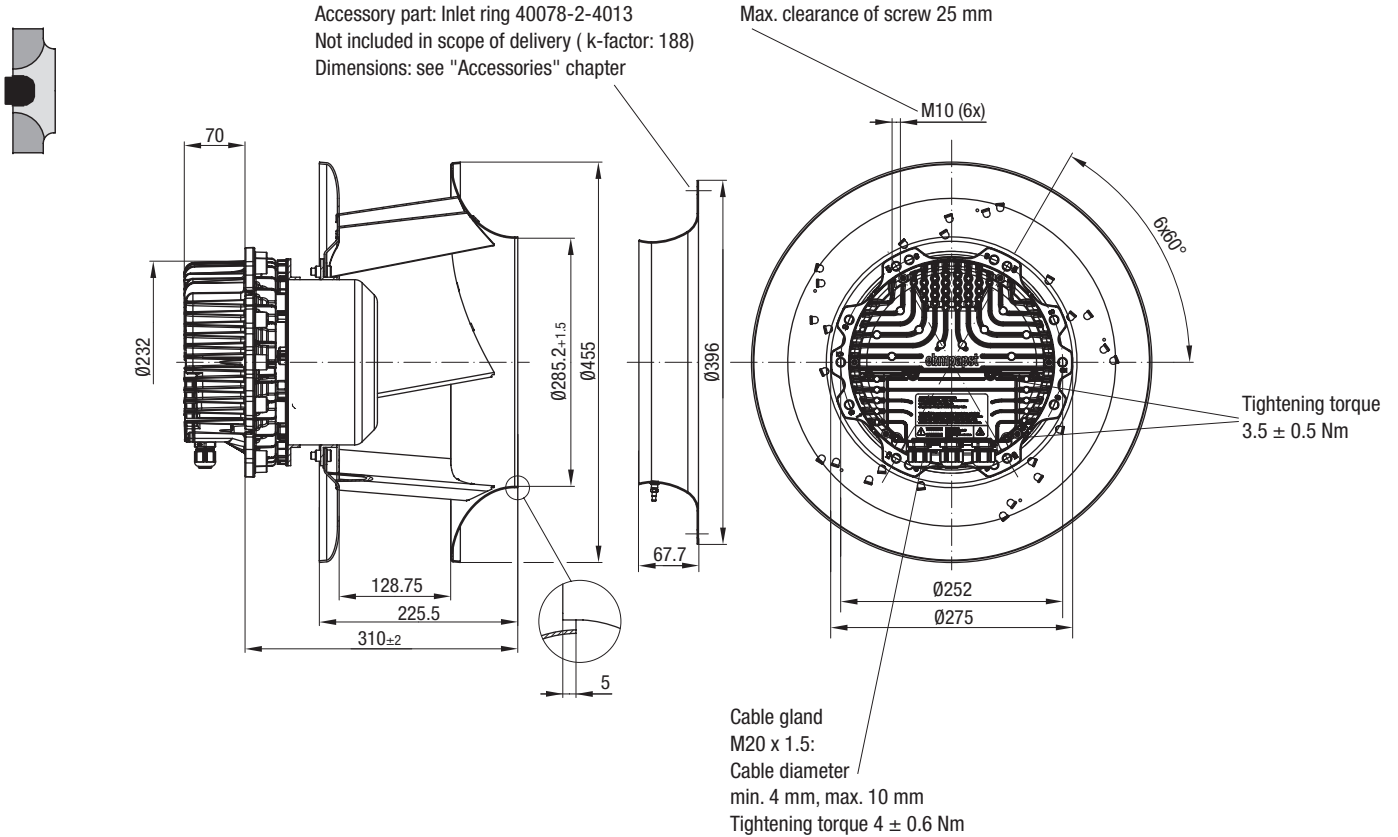

K3G 400-PA27-71 (Centrifugal module with support bracket)

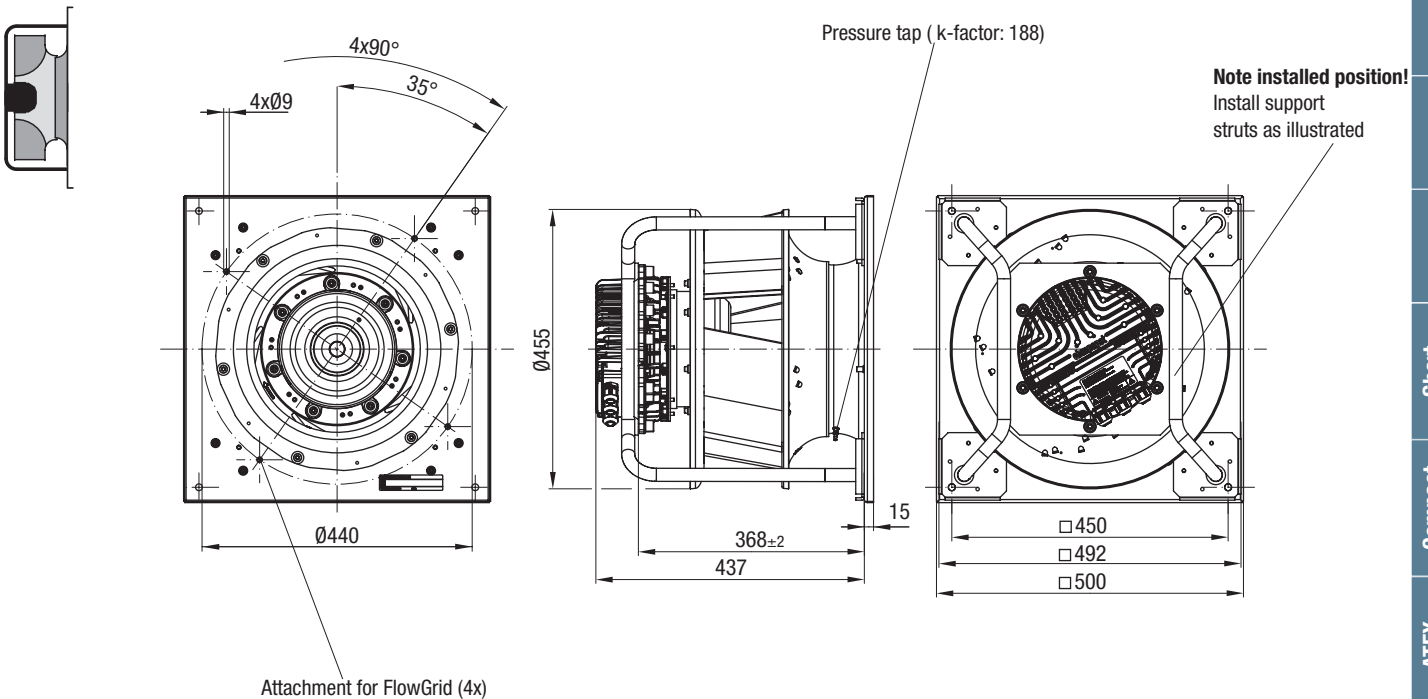

EC centrifugal fans – RadiPac

backward curved, Ø 450



- **Material:** Support bracket: Steel, painted black
Support plate and inlet ring: Sheet steel, galvanized
Impeller: Sheet aluminium
Rotor: Painted black
Electronics housing: Die-cast aluminium
- **Number of blades:** 5
- **Direction of rotation:** Clockwise viewed toward rotor
- **Degree of protection:** A IP 54; B C D IP 55
- **Insulation class:** A "B"; B C D "F"
- **Installation position:** Shaft horizontal or rotor on bottom, rotor on top on request
- **Condensation drainage holes:** Rotor side
- **Mode:** Continuous operation (S1)
- **Mounting:** Maintenance-free ball bearings

Nominal data		Curve	Nominal voltage range	Frequency	Speed ⁽¹⁾	Max. Input power ⁽¹⁾	Max. Input current ⁽¹⁾	Perm. ambient temp.	Weight	Techn. features and connection diagram
Type	Motor	VAC	Hz	rpm	kW	A	°C	kg		
*3G 450	M3G 112-IA	A 3~380-480	50/60	1790	1,74	2,70	-25..+50	17,0	P. 116 / RP1)	
*3G 450	M3G 150-FF	B 3~380-480	50/60	2140	2,90	4,50	-25..+60	23,5	P. 117 / RP2)	
*3G 450	M3G 150-FF	C 3~380-480	50/60	2200	3,19	4,60	-25..+40	27,5	P. 116 / RP1)	
*3G 450	M3G 150-IF	D 3~380-480	50/60	2600	5,25	8,00	-25..+50	31,0	P. 116 / RP1)	

Subject to change (1) Nominal data at operating point with maximum load and 400 VAC.

Curves

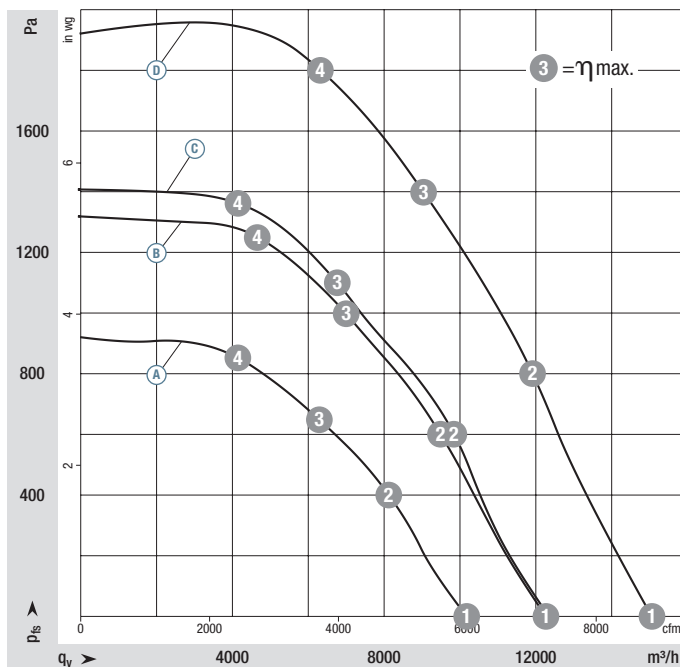

	n rpm	P _{ed} kW	I A	L _{wA} dB(A)
A 1	1790	1,00	1,61	91
A 2	1790	1,53	2,38	82
A 3	1790	1,74	2,70	77
A 4	1790	1,66	2,57	82
B 1	2140	1,71	2,69	96
B 2	2140	2,66	4,09	85
B 3	2140	2,90	4,50	81
B 4	2140	2,76	4,25	86
C 1	2200	1,96	2,84	96
C 2	2200	2,92	4,20	88
C 3	2200	3,19	4,60	87
C 4	2200	3,00	4,33	90
D 1	2600	3,07	4,78	102
D 2	2600	4,64	7,13	92
D 3	2600	5,25	8,00	87
D 4	2600	5,14	7,89	91

Air performance measured according to: ISO 5801, installation category A, with ebm-papst inlet ring without contact protection. Intake-side sound level: L_{wA} according to ISO 13347, L_{pA} measured at 1 m distance from fan axis. The values given are only applicable under the specified measuring conditions and may differ depending on the installation conditions. In the event of deviation from the standard configuration, the parameters must be checked in installed condition. See Page 126 ff. for detailed information.

- **Technical features:** See connection diagram P. 116 ff.
- **EMC:** ① Interference emission according to EN 61000-6-3, except EN 61000-3-2 for professionally used equipment with a total rated power greater than 1 kW
 - ② Immunity to interference according to EN 61000-6-2
- **Touch current:** <= 3,5 mA according to IEC 60990 (measuring circuit Fig. 4)
- **Terminal box design:** electrical connection via terminal strip
- **Protection class:** I (with customer connection of protective earth)
- **Conformity with standards:** EN 61800-5-1, CE
- **Approvals:** ③ C22.2 Nr.77 + CAN/CSA-E60730-1, UL 1004-7 + 60730
 - ④ ⑤ EAC
 - ⑥ EAC, UL, CSA
- **Efficiency:** Ecodesign EU regulation EU 327/2011



Weight centrifugal fan

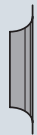

Weight centrifugal module with support bracket

Centrifugal fan	kg	Inlet ring with one pressure tap	Centrifugal module with support bracket	kg
R3G 450-PI86 -01	17,0	45075-2-4013	K3G 450-PI86 -02	32,0
R3G 450-PA23 -71	23,5	45075-2-4013	K3G 450-PA23 -71	37,0
R3G 450-PA21 -C1 ⁽²⁾	27,5	45075-2-4013	K3G 450-PA21 -C1 ⁽²⁾	45,5
R3G 450-PB24 -01	31,0	45075-2-4013	K3G 450-PB24 -01	47,4

(2) with Aktive-PFC

EC centrifugal fans – RadiPac

backward curved, Ø 450



R3G 450-PI86-01 (Centrifugal fan)

Accessory part: Inlet ring 45075-2-4013
Not included in scope of delivery (k-factor: 240)
Dimensions: see "Accessories" chapter

Max. clearance of screw 20 mm

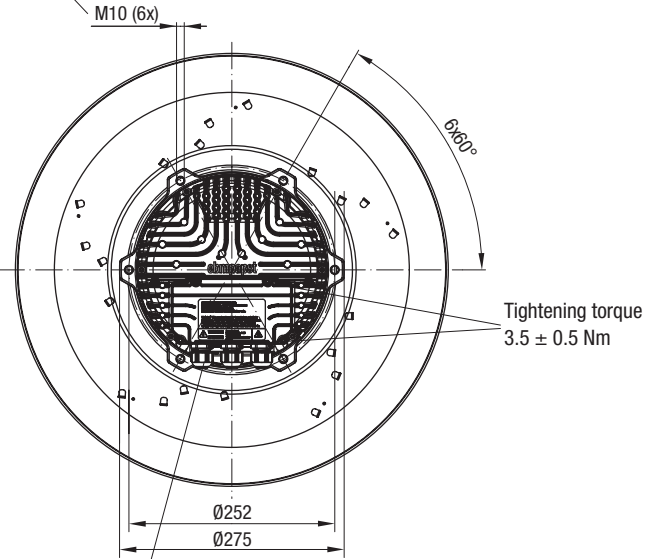
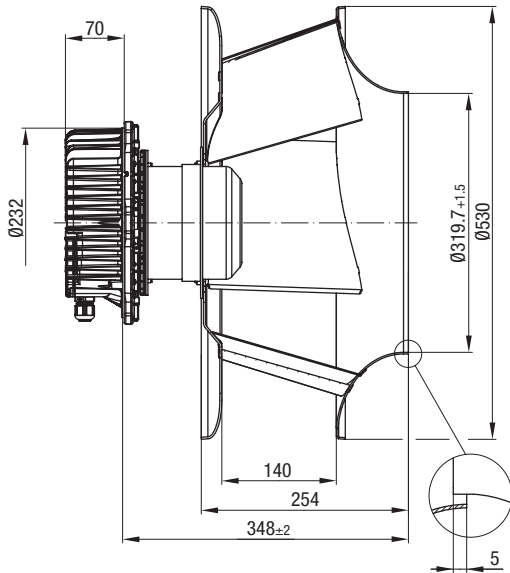

Cable gland
M20 x 1.5:
Cable diameter
min. 4 mm, max. 10 mm
Tightening torque 4 ± 0.6 Nm

K3G 450-PI86-02 (Centrifugal module with support bracket)

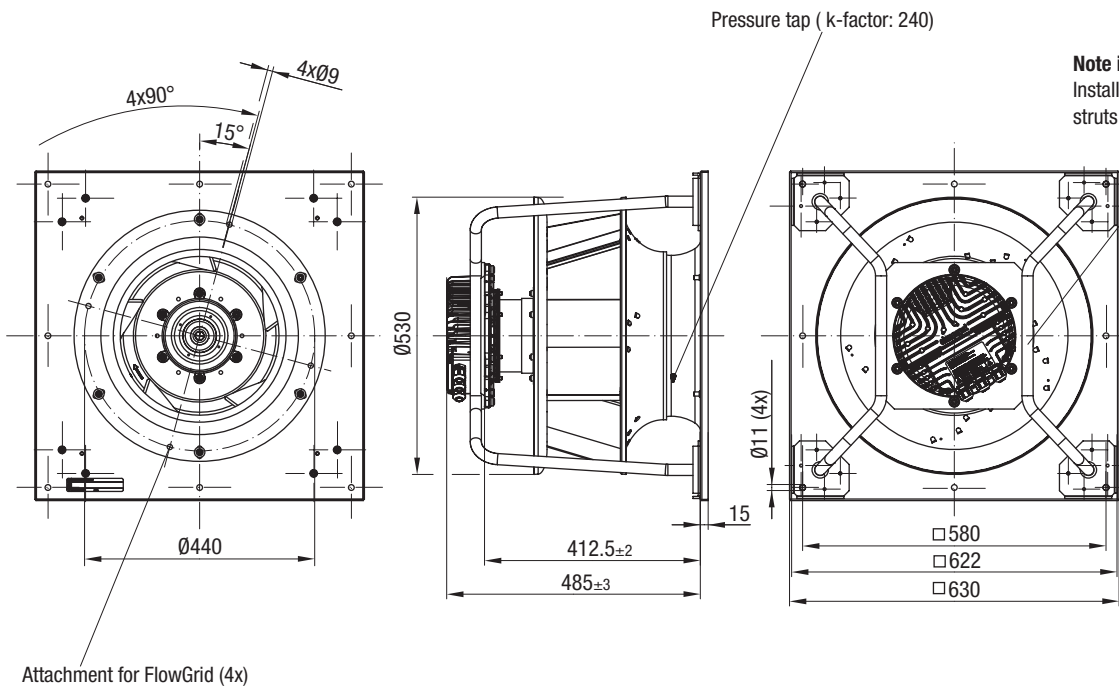

Attachment for FlowGrid (4x)

Note installed position!
Install support
struts as illustrated

EC centrifugal fans – RadiPac

backward curved, Ø 450



R3G 450-PA23-71 (Centrifugal fan)



Accessory part: Inlet ring 45075-2-4013
Not included in scope of delivery (k-factor: 240)
Dimensions: see "Accessories" chapter

Max. clearance of screw 25 mm

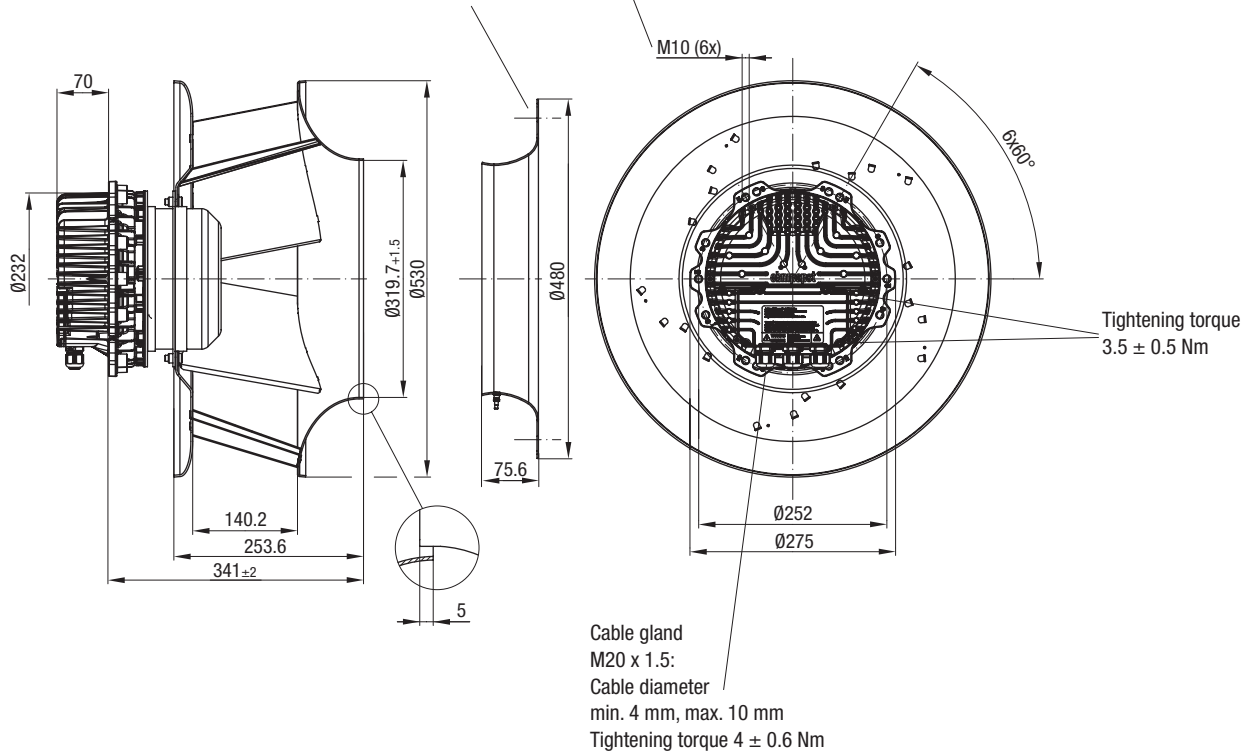

K3G 450-PA23-71 (Centrifugal module with support bracket)

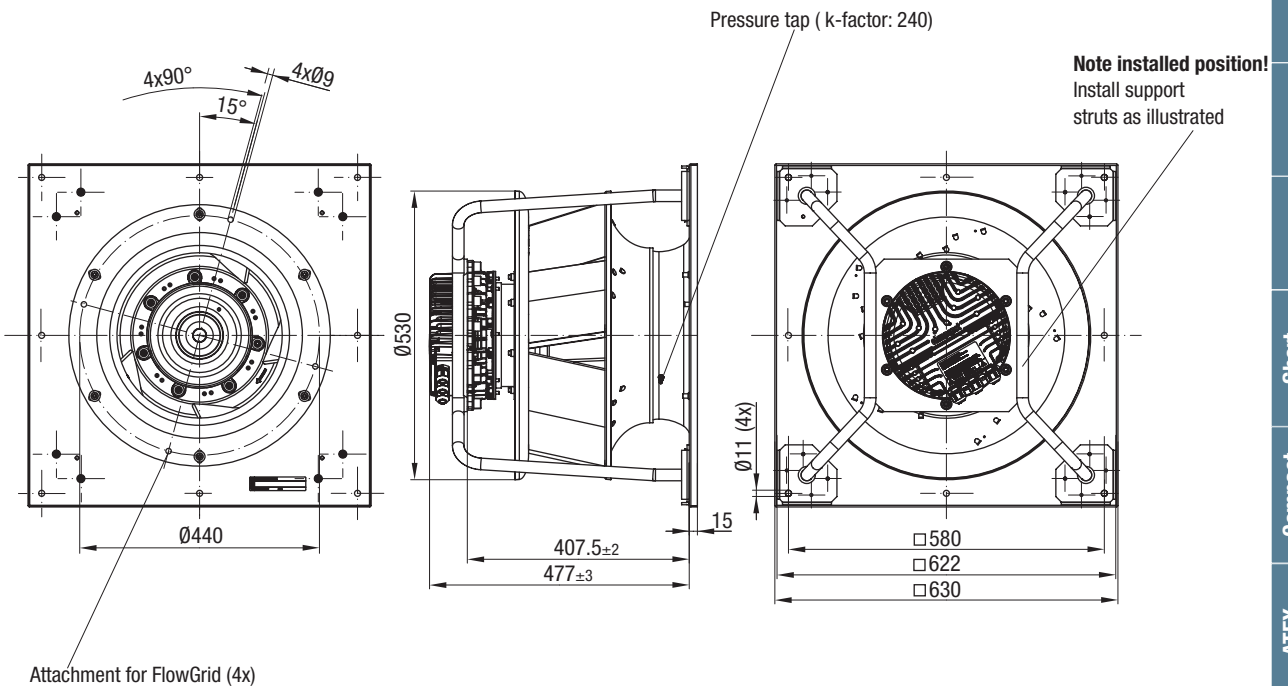

EC centrifugal fans – RadiPac

backward curved, Ø 450 (Active-PFC)



R3G 450-PA21-C1 (Centrifugal fan)



Accessory part: Inlet ring 45075-2-4013
Not included in scope of delivery (k-factor: 240)
Dimensions: see "Accessories" chapter

Max. clearance of screw 20 mm

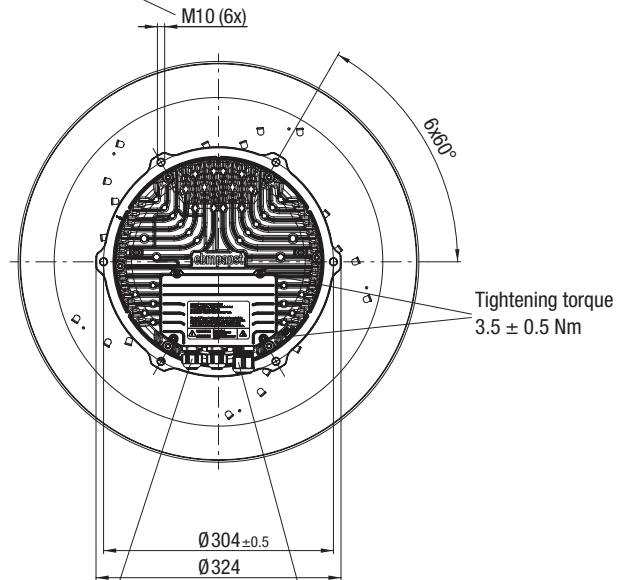
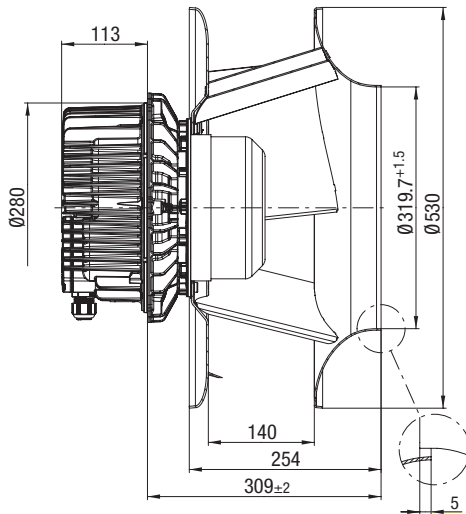

Cable gland
M20 x 1.5 (2x):
Cable diameter
min. 4 mm, max. 10 mm
Tightening torque 4 ± 0.6 Nm

Cable gland
M25 x 1.5:
Cable diameter
min. 9 mm, max. 16 mm
Tightening torque 6 ± 0.9 Nm

K3G 450-PA21-C1 (Centrifugal module with support bracket)

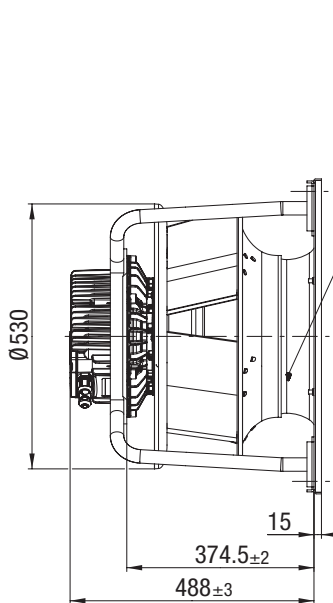
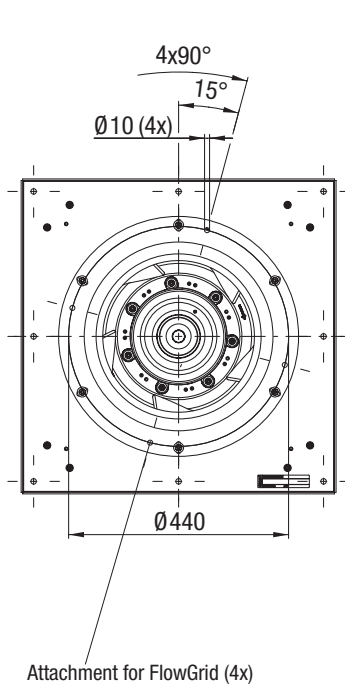

Pressure tap (k-factor: 240)

Note installed position!
Install support
struts as illustrated

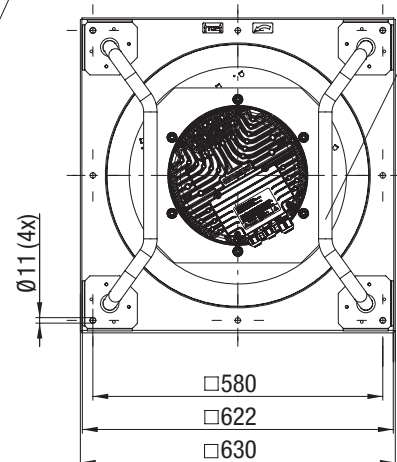

EC centrifugal fans – RadiPac

backward curved, Ø 450



R3G 450-PB24-01 (Centrifugal fan)

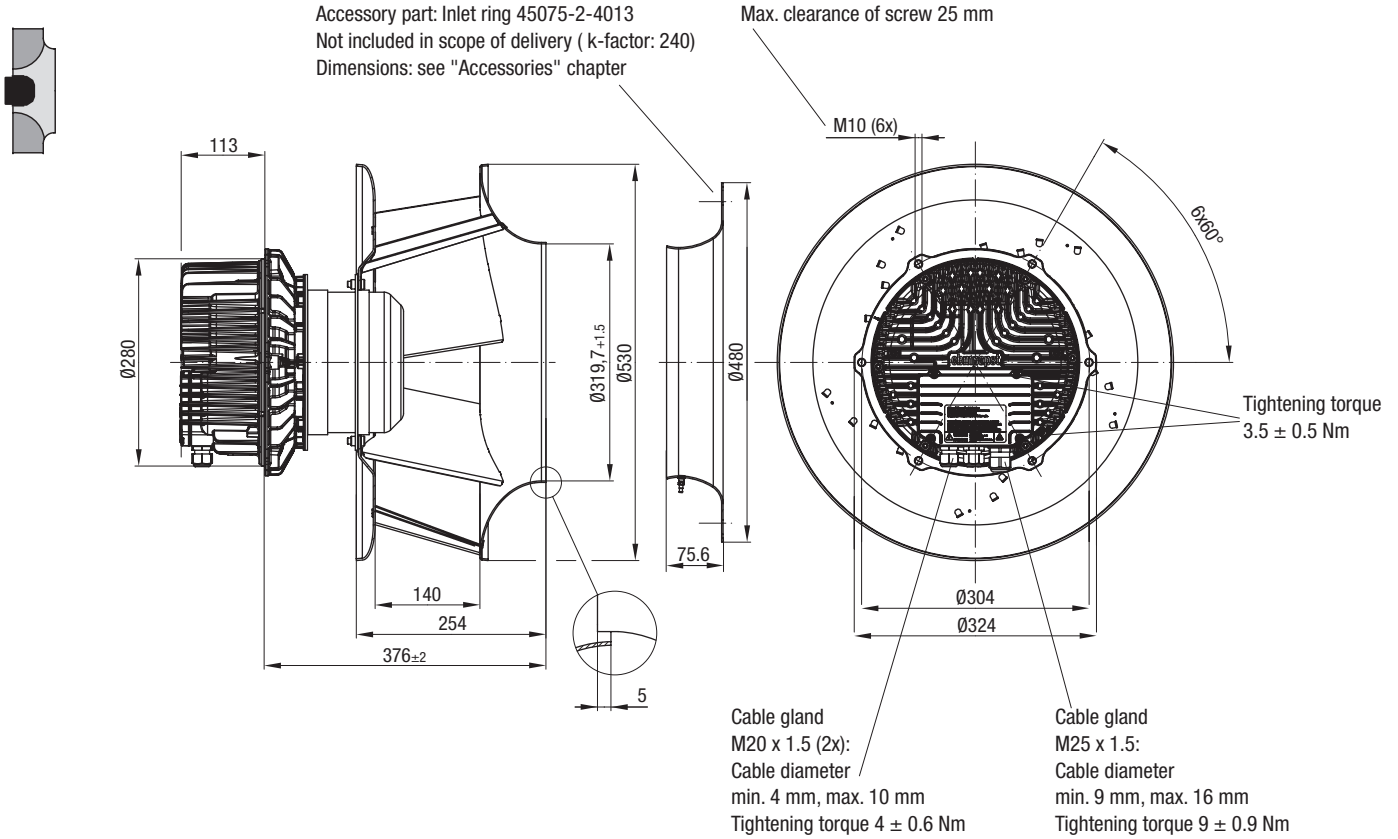

K3G 450-PB24-01 (Centrifugal module with support bracket)

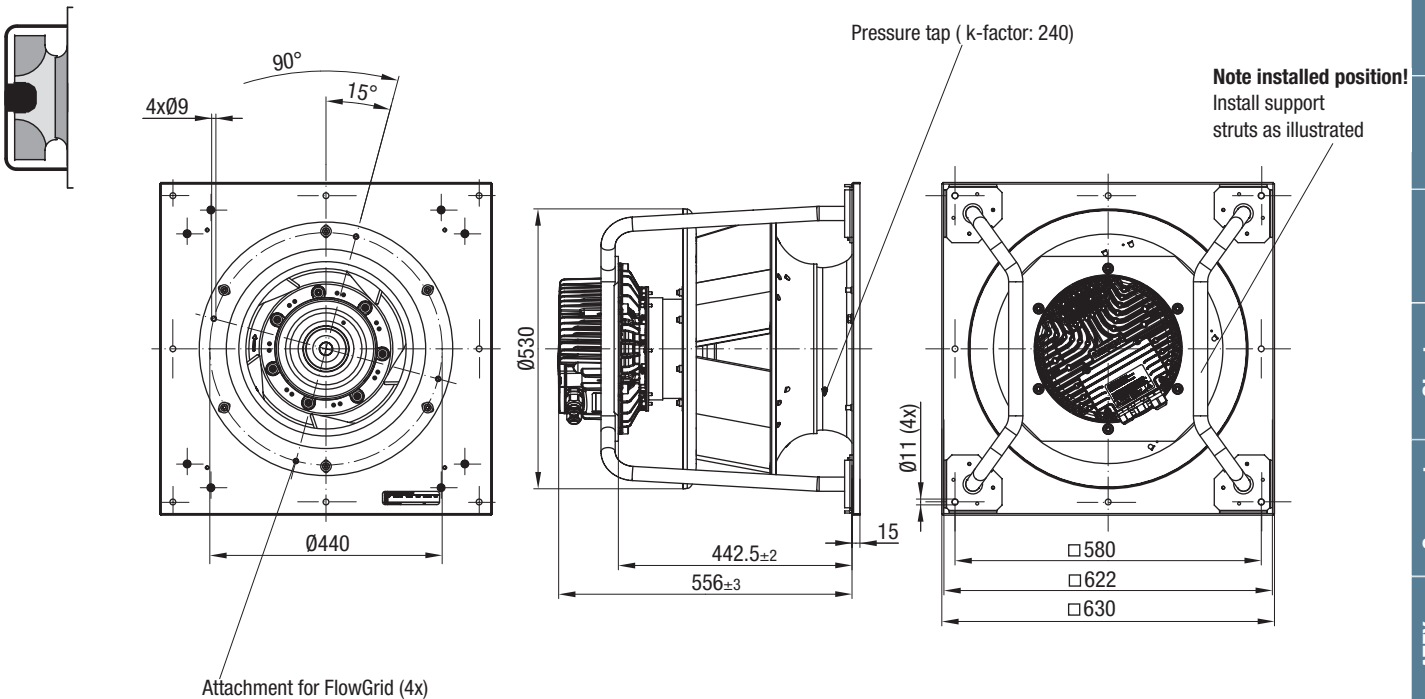

EC centrifugal fans – RadiPac

backward curved, Ø 500



- **Material:** Support bracket: Steel, painted black
Support plate and inlet ring: Sheet steel, galvanized
Impeller: Sheet aluminium
Rotor: Painted black
Electronics housing: Die-cast aluminium
- **Number of blades:** 5
- **Direction of rotation:** Clockwise viewed toward rotor
- **Degree of protection:** IP 55
- **Insulation class:** "F"
- **Installation position:** Shaft horizontal or rotor on bottom, rotor on top on request
- **Condensation drainage holes:** Rotor side
- **Mode:** Continuous operation (S1)
- **Mounting:** Maintenance-free ball bearings

Nominal data

Type	Motor	Curve	Nominal voltage range	Frequency	Speed ⁽¹⁾	Max. Input power ⁽¹⁾	Max. Input current ⁽¹⁾	Perm. ambient temp.	Weight	Techn. features and connection diagram
Type	Motor	VAC	Hz	rpm	kW	A	°C	kg		
*3G 500	M3G 150-FF	Ⓐ 3~380-480	50/60	1810	3,10	4,50	-25..+40	28,5	P. 116 / RP1)	
*3G 500	M3G 150-FF	Ⓑ 3~380-480	50/60	1910	3,45	5,30	-25..+40	24,3	P. 117 / RP2)	
*3G 500	M3G 150-IF	Ⓒ 3~380-480	50/60	2250	5,70	9,00	-25..+40	32,0	P. 116 / RP1)	

Subject to change

(1) Nominal data at operating point with maximum load and 400 VAC.

Curves

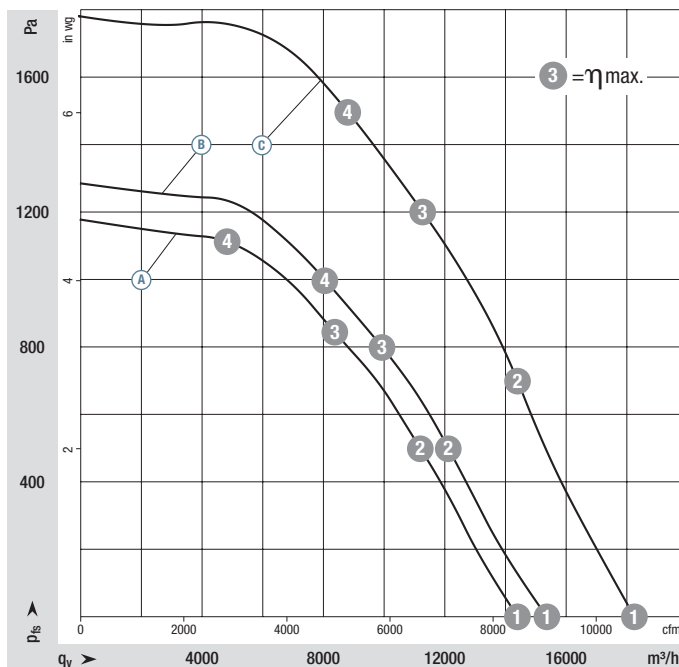

	n rpm	P _{ed} kW	I A	L _{wA} dB(A)
Ⓐ 1	1810	1,80	2,60	102
Ⓐ 2	1810	2,70	3,90	91
Ⓐ 3	1810	3,10	4,50	82
Ⓐ 4	1810	2,85	4,10	86
Ⓑ 1	1910	1,98	3,09	102
Ⓑ 2	1910	2,92	4,49	92
Ⓑ 3	1910	3,38	5,19	86
Ⓑ 4	1910	3,45	5,30	83
Ⓒ 1	2250	3,24	5,05	105
Ⓒ 2	2250	4,86	7,47	95
Ⓒ 3	2250	5,70	9,00	88
Ⓒ 4	2250	5,70	8,74	87

Air performance measured according to: ISO 5801, installation category A, with ebm-papst inlet ring without contact protection. Intake-side sound level: L_{wA} according to ISO 13347, L_{pA} measured at 1 m distance from fan axis. The values given are only applicable under the specified measuring conditions and may differ depending on the installation conditions. In the event of deviation from the standard configuration, the parameters must be checked in installed condition. See Page 126 ff. for detailed information.

- **Technical features:** See connection diagram P. 116 f.
- **EMC:**
 - ⓑ Interference emission according to EN 61000-6-4
 - ⓒ Interference emission according to EN 61000-6-3, except EN 61000-3-2 for professionally used equipment with a total rated power greater than 1 kW
 - ⓑⓒ Immunity to interference according to EN 61000-6-2
- **Touch current:** <= 3,5 mA according to IEC 60990 (measuring circuit Fig. 4)
- **Terminal box design:** electrical connection via terminal strip
- **Protection class:** I (with customer connection of protective earth)
- **Conformity with standards:** EN 61800-5-1, CE
- **Approvals:** ⓐ ⓑ ⓓ EAC
 - ⓒ C22.2 Nr.77 + CAN/CSA-E60730-1, UL 1004-7 + 60730
- **Efficiency:** Ecodesign EU regulation EU 327/2011



Weight centrifugal fan

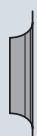

Inlet ring with one pressure tap



Weight centrifugal module with support bracket

Centrifugal fan	kg	Inlet ring with one pressure tap	Centrifugal module with support bracket	kg
R3G 500-PA26 -C1 ⁽²⁾	28,5	64025-2-4013	K3G 500-PA26 -C1 ⁽²⁾	46,5
R3G 500-PA23 -71	24,3	64025-2-4013	K3G 500-PA23 -71	38,7
R3G 500-PB33 -01	32,0	64025-2-4013	K3G 500-PB33 -01	48,0

⁽²⁾ with Aktive-PFC

EC centrifugal fans – RadiPac

backward curved, Ø 500 (Active-PFC)



R3G 500-PA26-C1 (Centrifugal fan)



Accessory part: Inlet ring 64025-2-4013
Not included in scope of delivery (k-factor: 281)
Dimensions: see "Accessories" chapter

Max. clearance of screw 20 mm

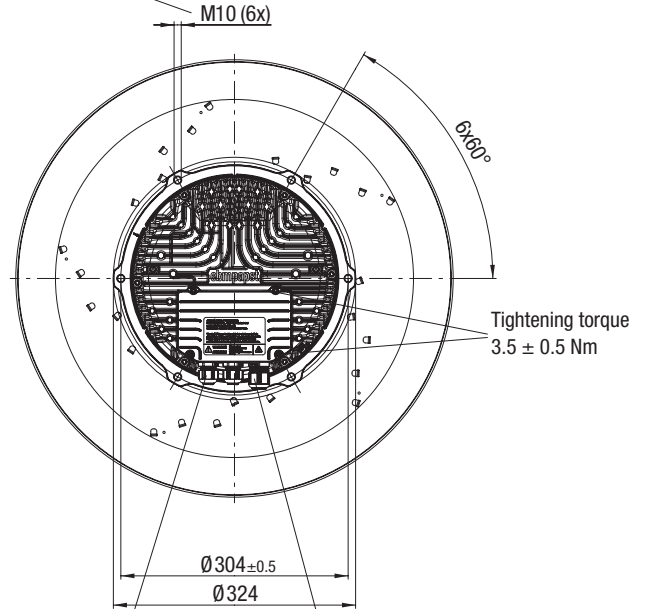
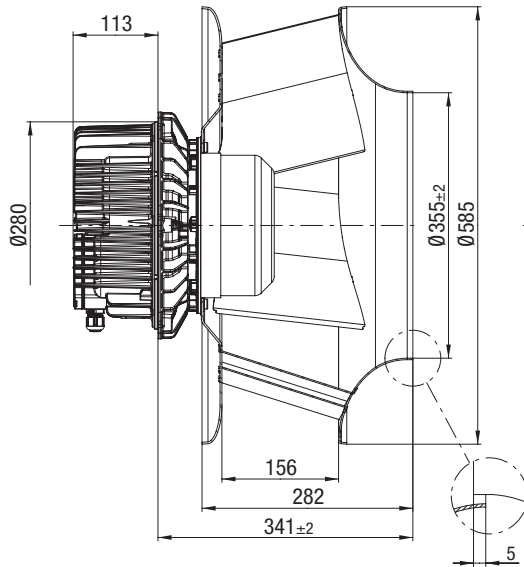

Cable gland
M20 x 1.5 (2x):
Cable diameter
min. 4 mm, max. 10 mm
Tightening torque 4 ± 0.6 Nm

Cable gland
M25 x 1.5:
Cable diameter
min. 9 mm, max. 16 mm
Tightening torque 6 ± 0.9 Nm

K3G 500-PA26-C1 (Centrifugal module with support bracket)

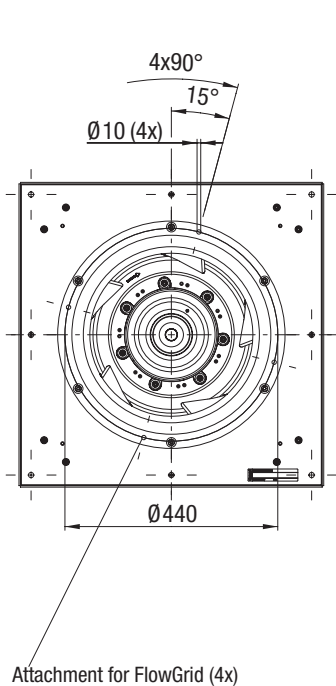

Pressure tap (k-factor: 281)

Note installed position!
Install support
struts as illustrated

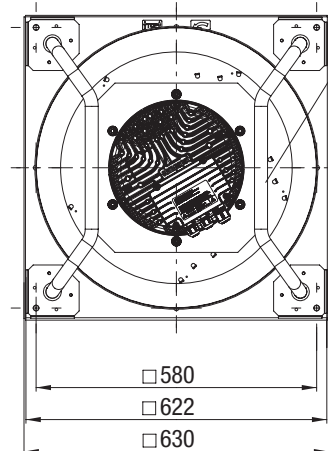
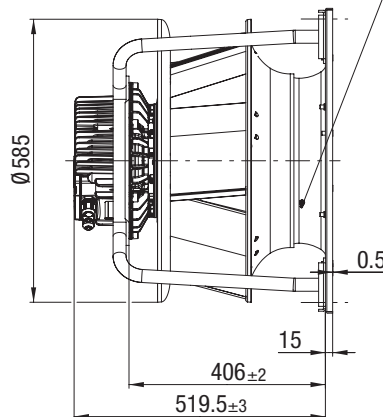

EC centrifugal fans – RadiPac

backward curved, Ø 500



R3G 500-PA23-71 (Centrifugal fan)



Accessory part: Inlet ring 64025-2-4013
Not included in scope of delivery (k-factor: 281)
Dimensions: see "Accessories" chapter

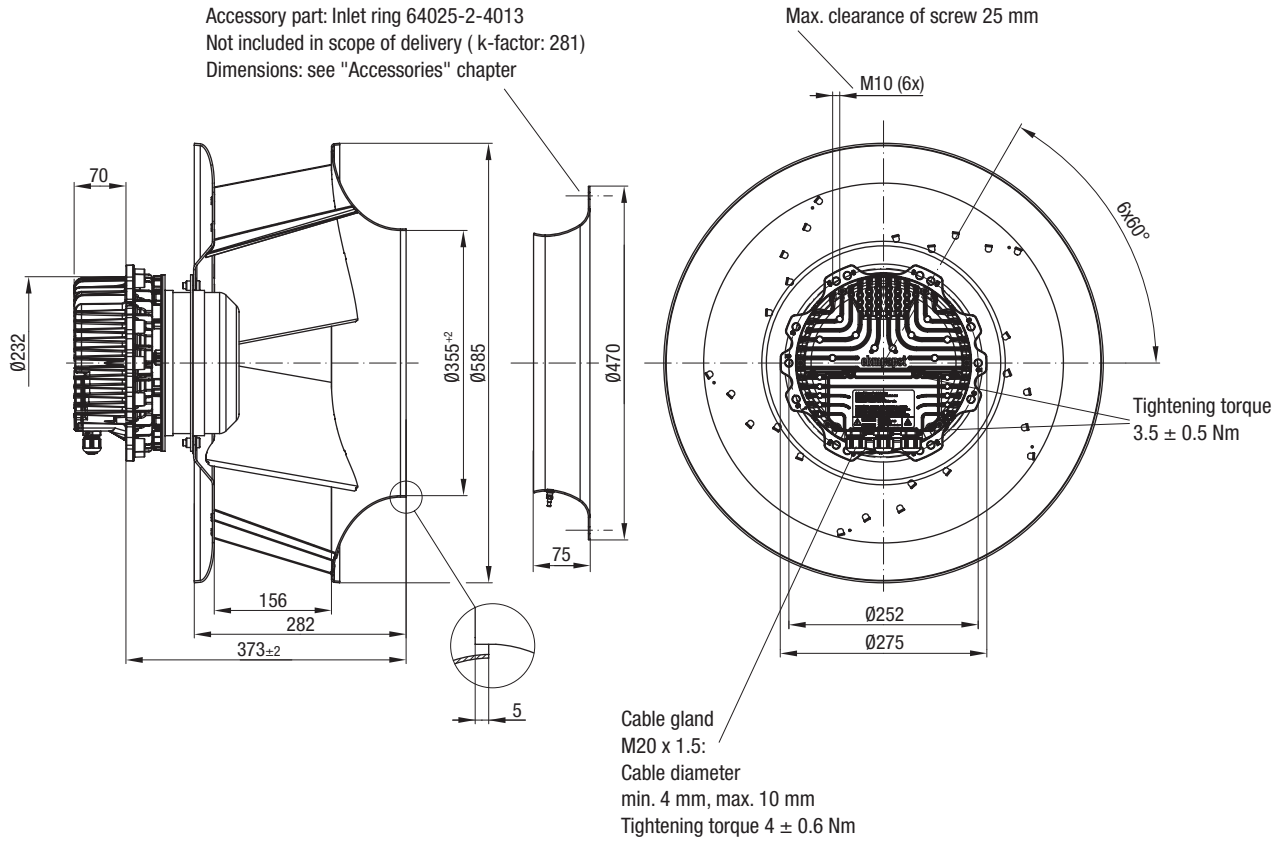

K3G 500-PA23-71 (Centrifugal module with support bracket)

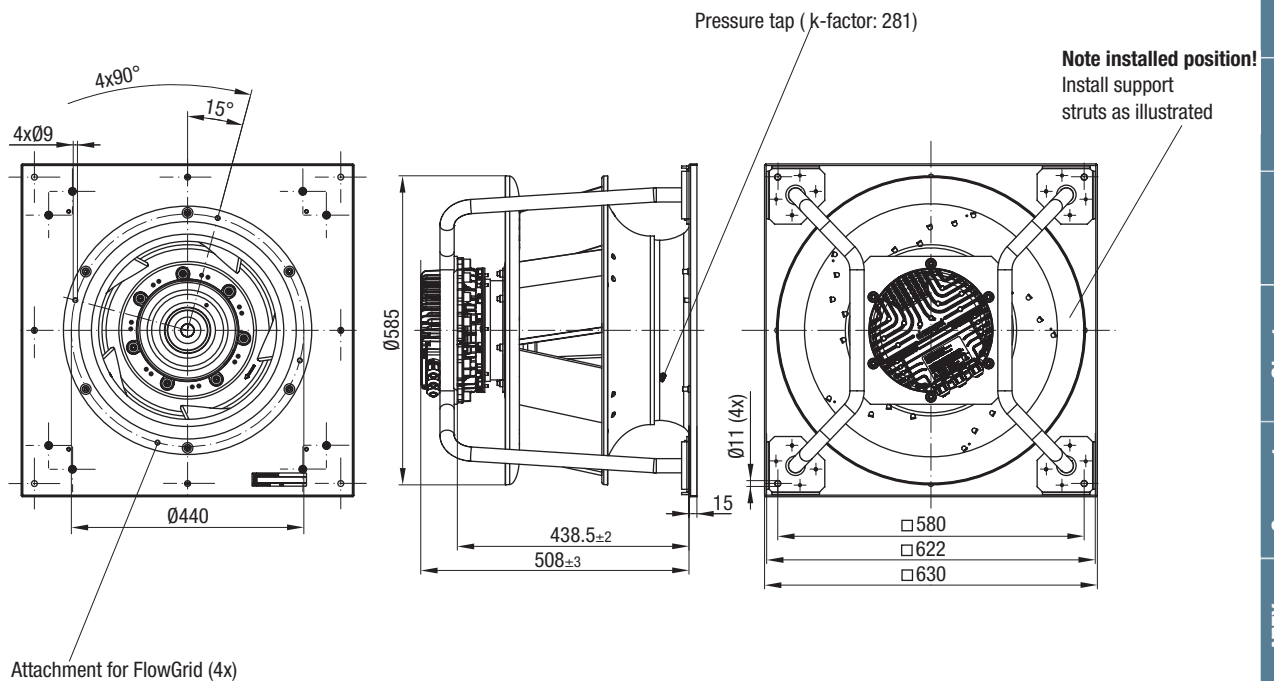

EC centrifugal fans – RadiPac

backward curved, Ø 500



R3G 500-PB33-01 (Centrifugal fan)



Accessory part: Inlet ring 64025-2-4013
Not included in scope of delivery (k-factor: 281)
Dimensions: see "Accessories" chapter

Max. clearance of screw 20 mm

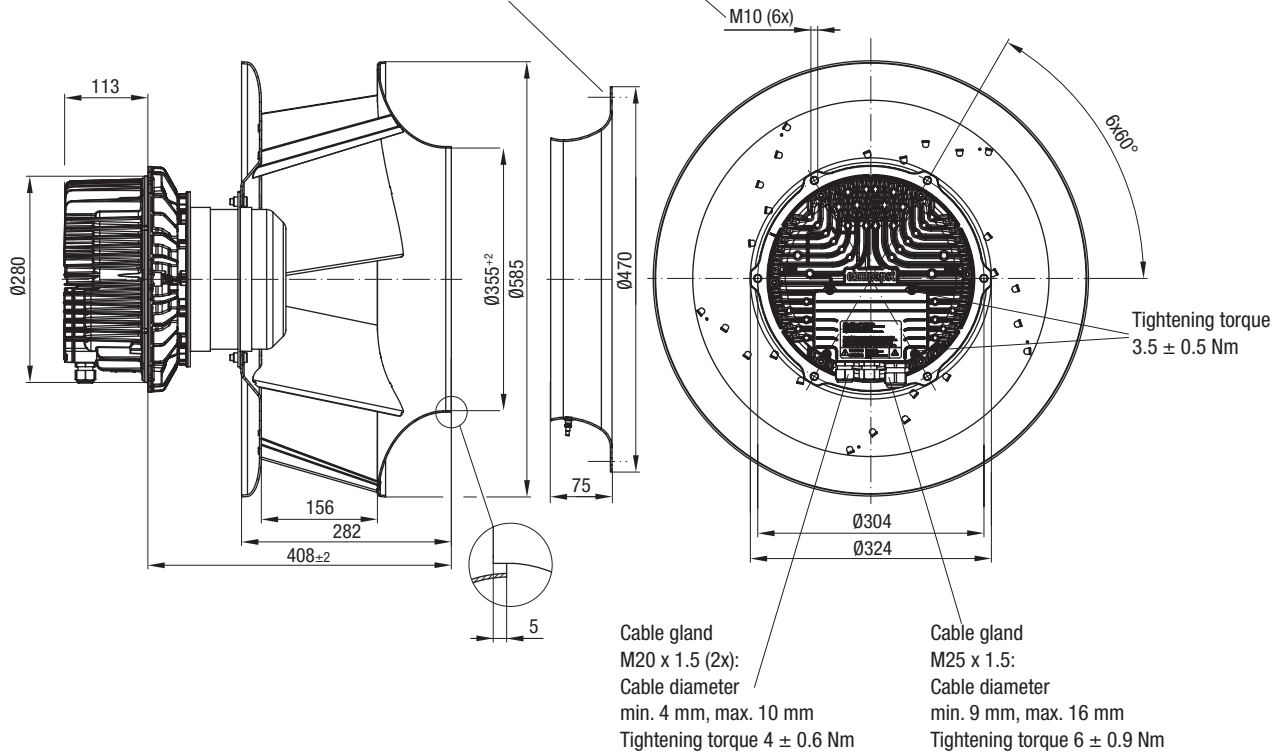

K3G 500-PB33-01 (Centrifugal module with support bracket)

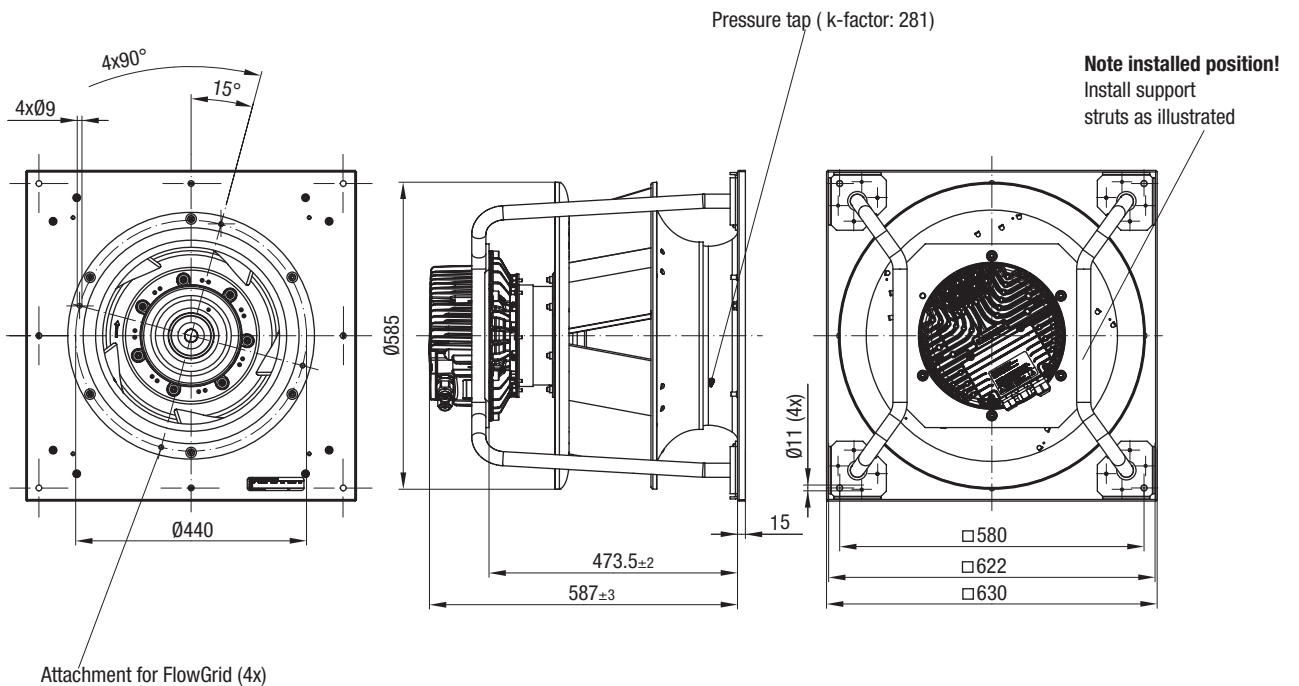

Agents	Technology	ATEX version	Compact version	Short version	Ø 1000	Ø 800	Ø 710	Ø 630	Ø 560	Ø 500	Ø 450	Ø 400	Ø 355	Ø 310	Ø 280	Ø 250	Information
--------	------------	--------------	-----------------	---------------	--------	-------	-------	-------	-------	-------	-------	-------	-------	-------	-------	-------	-------------

EC centrifugal fans – RadiPac

backward curved, Ø 560



- **Material:** Support bracket: Steel, painted black
Support plate and inlet ring: Sheet steel, galvanized
Impeller: Sheet aluminium
Rotor: Painted black
Electronics housing: Die-cast aluminium
- **Number of blades:** 5
- **Direction of rotation:** Clockwise viewed toward rotor
- **Degree of protection:** IP 55
- **Insulation class:** "F"
- **Installation position:** Shaft horizontal or rotor on bottom, rotor on top on request
- **Condensation drainage holes:** Rotor side
- **Mode:** Continuous operation (S1)
- **Mounting:** Maintenance-free ball bearings

Nominal data

Type	Motor	Curve	Nominal voltage range	Frequency	Speed ⁽¹⁾	Max. Input power ⁽¹⁾	Max. Input current ⁽¹⁾	Perm. ambient temp.	Weight	Techn. features and connection diagram
Type	Motor	VAC	Hz	rpm	kW	A	°C	kg		
*3G 560	M3G 150-IF	Ⓐ 3~380-480	50/60	1470	3,06	4,40	-25..+40	34,0	P. 116 / RP1)	
*3G 560	M3G 150-IF	Ⓑ 3~380-480	50/60	1540	3,30	5,10	-25..+50	30,5	P. 117 / RP2)	
*3G 560	M3G 150-NA	Ⓒ 3~380-480	50/60	1760	5,00	7,70	-25..+40	38,5	P. 116 / RP1)	

Subject to change

(1) Nominal data at operating point with maximum load and 400 VAC.

Curves

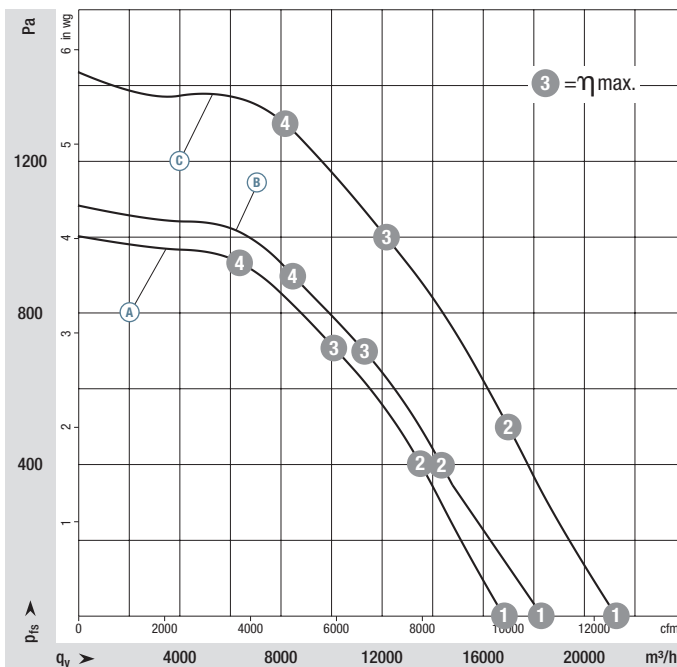

	n rpm	P _{ed} kW	I A	L _{wA} dB(A)
Ⓐ ①	1470	1,80	2,60	96
Ⓐ ②	1470	2,71	3,94	87
Ⓐ ③	1470	3,06	4,40	79
Ⓐ ④	1470	2,83	4,10	83
Ⓑ ①	1540	1,83	2,88	97
Ⓑ ②	1540	2,81	4,32	88
Ⓑ ③	1540	3,30	5,10	82
Ⓑ ④	1540	3,23	4,95	82
Ⓒ ①	1760	2,79	4,36	101
Ⓒ ②	1760	4,25	6,52	92
Ⓒ ③	1760	5,00	7,70	84
Ⓒ ④	1760	4,79	7,32	87

Air performance measured according to: ISO 5801, installation category A, with ebm-papst inlet ring without contact protection. Intake-side sound level: L_{wA} according to ISO 13347, L_{pA} measured at 1 m distance from fan axis. The values given are only applicable under the specified measuring conditions and may differ depending on the installation conditions. In the event of deviation from the standard configuration, the parameters must be checked in installed condition. See Page 126 ff. for detailed information.

- **Technical features:** See connection diagram P. 116 f.
- **EMC:** ⓑ ⓐ Interference emission according to EN 61000-6-3, except EN 61000-3-2 for professionally used equipment with a total rated power greater than 1 kW
Immunity to interference according to EN 61000-6-2
- **Touch current:** <= 3,5 mA according to IEC 60990 (measuring circuit Fig. 4)
- **Terminal box design:** electrical connection via terminal strip
- **Protection class:** I (with customer connection of protective earth)
- **Conformity with standards:** EN 61800-5-1, CE
- **Approvals:** Ⓐ Ⓑ EAC
Ⓒ C22.2 Nr.77 + CAN/CSA-E60730-1, UL 1004-7 + 60730
- **Efficiency:** Ecodesign EU regulation EU 327/2011



Weight centrifugal fan

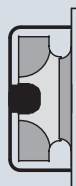

Weight centrifugal module with support bracket

Centrifugal fan	kg	Inlet ring with one pressure tap	Centrifugal module with support bracket	kg
R3G 560-PB22 -C1 ⁽²⁾	34,0	64030-2-4013	K3G 560-PB22 -C1 ⁽²⁾	61,0
R3G 560-PB31 -71	30,5	64030-2-4013	K3G 560-PB31 -71	52,0
R3G 560-PC04 -01	38,5	64030-2-4013	K3G 560-PC04 -01	68,0

⁽²⁾ with Aktive-PFC

EC centrifugal fans – RadiPac

backward curved, Ø 560 (Active-PFC)



R3G 560-PB22-C1 (Centrifugal fan)



Accessory part: Inlet ring 64030-2-4013
Not included in scope of delivery (k-factor: 348)
Dimensions: see "Accessories" chapter

Max. clearance of screw 20 mm

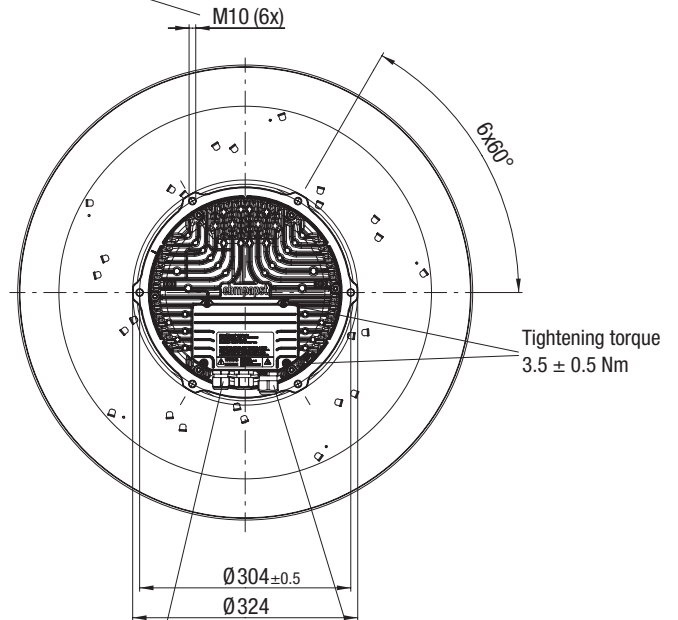
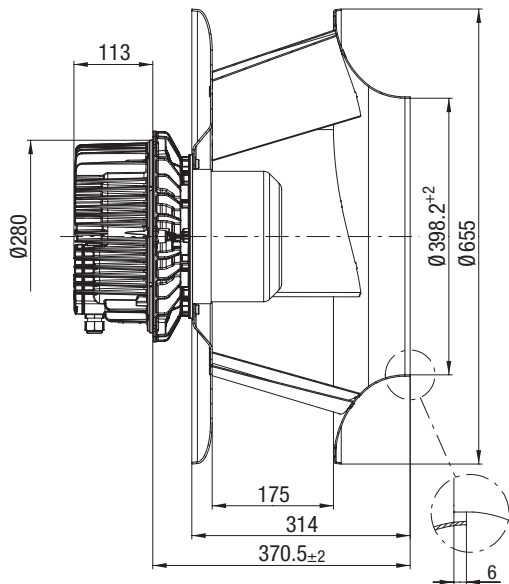

Cable gland
M20 x 1.5 (2x):
Cable diameter
min. 4 mm, max. 10 mm
Tightening torque 4 ± 0.6 Nm

Cable gland
M25 x 1.5:
Cable diameter
min. 9 mm, max. 16 mm
Tightening torque 6 ± 0.9 Nm

K3G 560-PB22-C1 (Centrifugal module with support bracket)

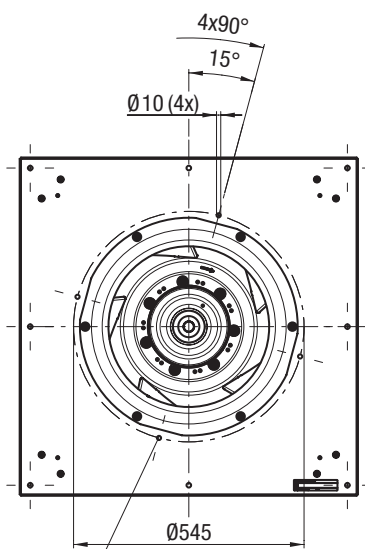

Attachment for FlowGrid (4x)

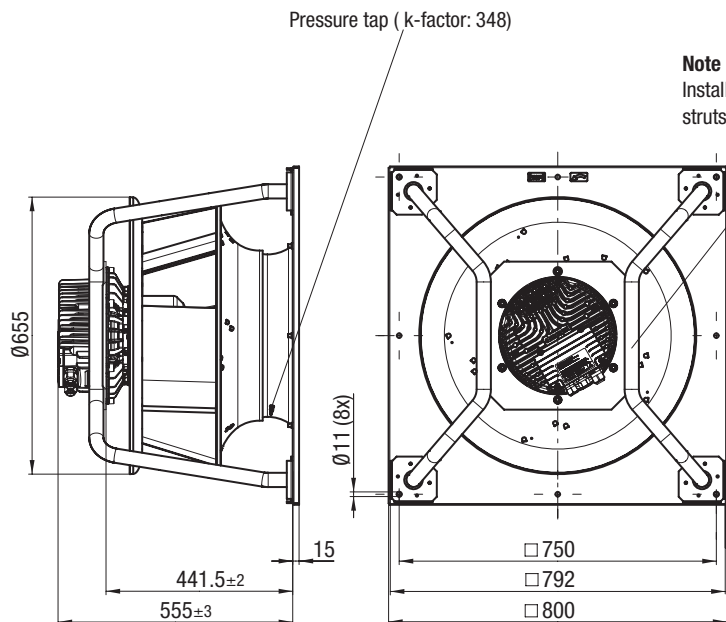

Note installed position!
Install support
struts as illustrated

EC centrifugal fans – RadiPac

backward curved, Ø 560



R3G 560-PB31-71 (Centrifugal fan)

Accessory part: Inlet ring 64030-2-4013
Not included in scope of delivery (k-factor: 348)
Dimensions: see "Accessories" chapter

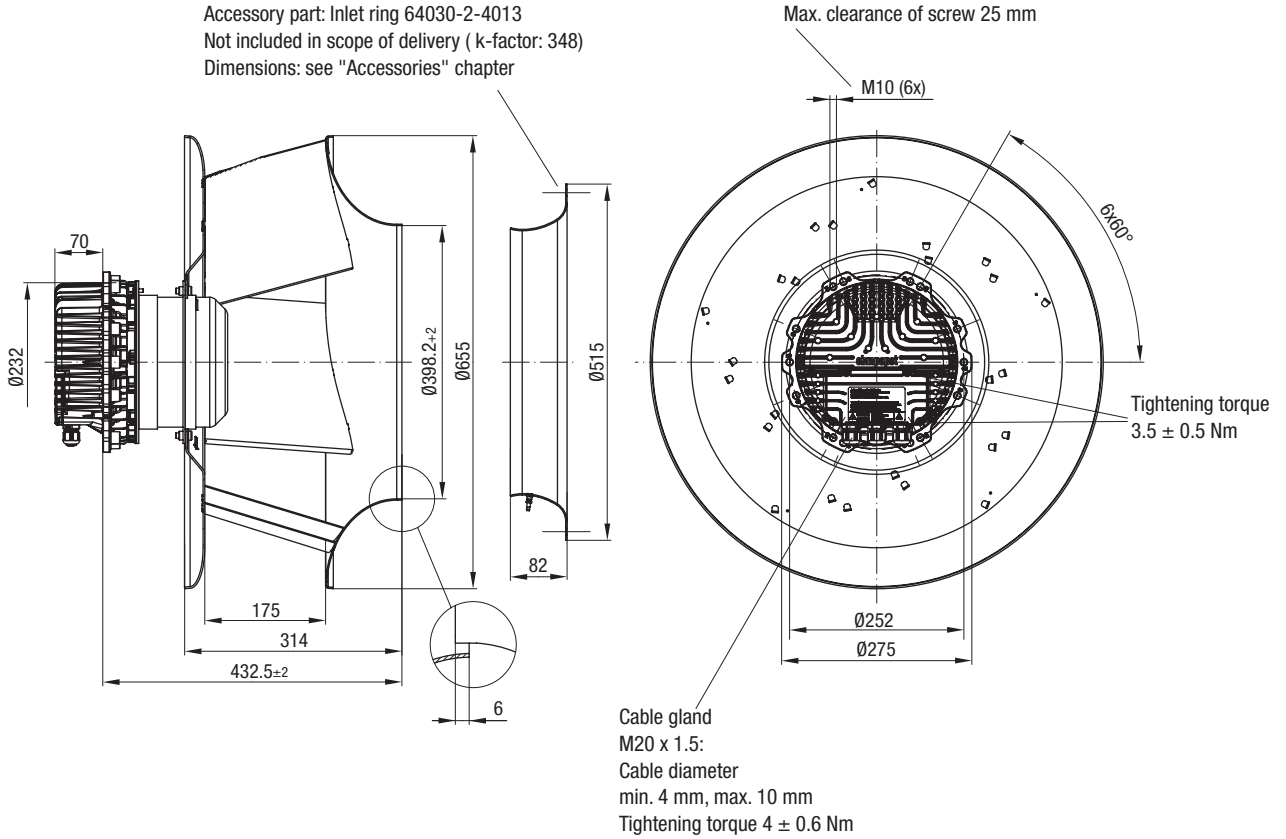

K3G 560-PB31-71 (Centrifugal module with support bracket)

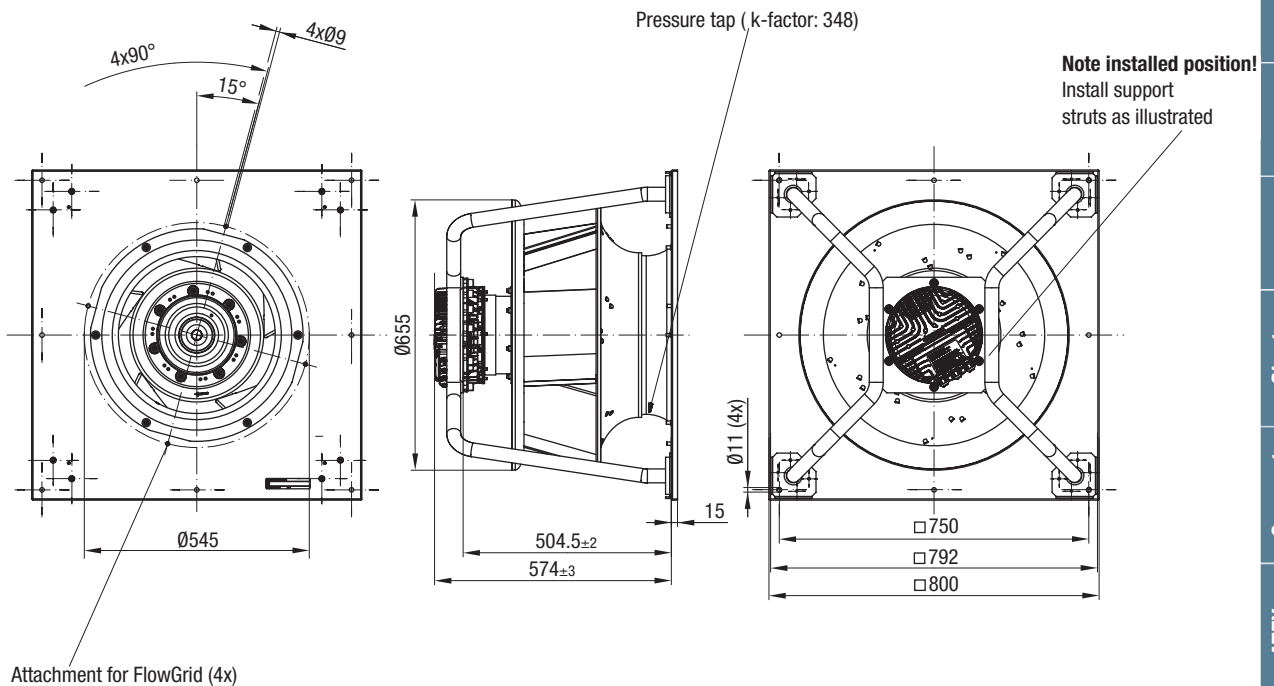

EC centrifugal fans – RadiPac

backward curved, Ø 560



R3G 560-PC04-01 (Centrifugal fan)



Accessory part: Inlet ring 64030-2-4013
Not included in scope of delivery (k-factor: 348)
Dimensions: see "Accessories" chapter

Max. clearance of screw 20 mm

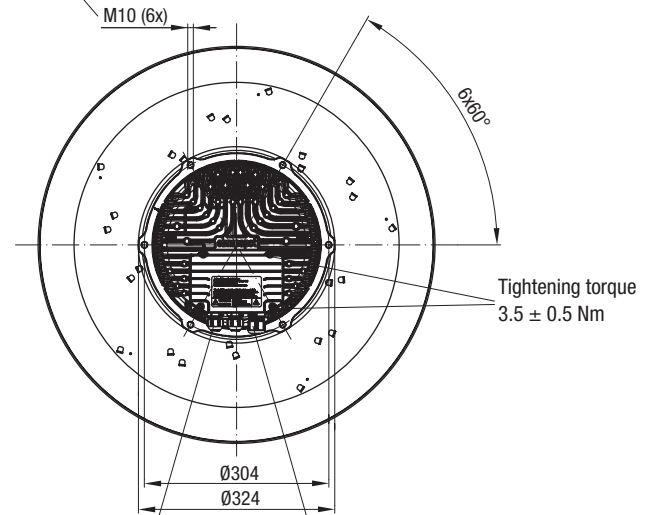
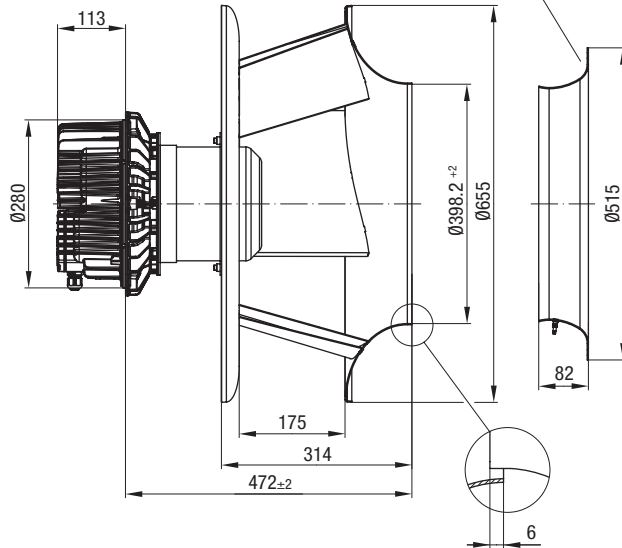

Cable gland
M20 x 1.5 (2x):
Cable diameter
min. 4 mm, max. 10 mm
Tightening torque 4 ± 0.6 Nm

Cable gland
M25 x 1.5:
Cable diameter
min. 9 mm, max. 16 mm
Tightening torque 6 ± 0.9 Nm

K3G 560-PC04-01 (Centrifugal module with support bracket)



Pressure tap (k-factor: 348)

Note installed position!
Install support
struts as illustrated

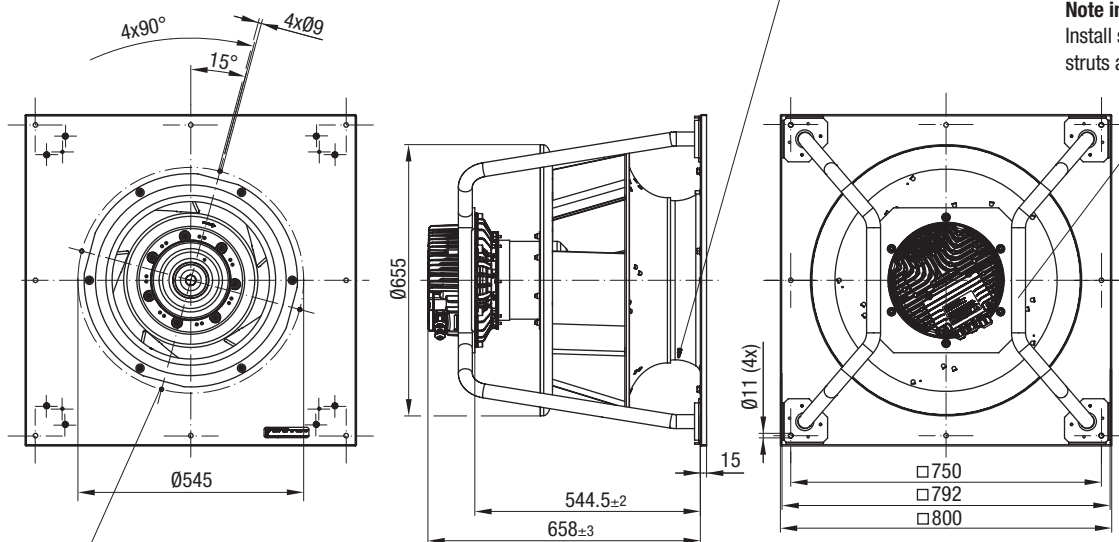

Attachment for FlowGrid (4x)

Agents	Technology	ATEX version	Compact version	Short version	Ø 1000	Ø 800	Ø 710	Ø 630	Ø 560	Ø 500	Ø 450	Ø 400	Ø 355	Ø 310	Ø 280	Ø 250	Information
--------	------------	--------------	-----------------	---------------	--------	-------	-------	-------	-------	-------	-------	-------	-------	-------	-------	-------	-------------

EC centrifugal fans – RadiPac

backward curved, Ø 630



- **Material:** Support plate and inlet ring: Sheet steel, galvanized
 (A) (B) Support bracket: Steel, painted black
 (C) (D) Cube design, Spacer: Aluminium
 Impeller: Sheet aluminium; Rotor: Painted black
 Electronics housing: Die-cast aluminium
- **Number of blades:** 5
- **Direction of rotation:** Clockwise viewed toward rotor
- **Degree of protection:** (A) (B) IP 55; (C) (D) IP 54
- **Insulation class:** "F"
- **Installation position:** Shaft horizontal ((C) (D) base mounting only) or rotor on bottom, rotor on top on request
- **Condensation drainage holes:** Rotor side
- **Mode:** Continuous operation (S1)
- **Mounting:** Maintenance-free ball bearings

Nominal data

Type	Motor	Curve	Nominal voltage range	Frequency	Speed ⁽¹⁾	Max. Input power ⁽¹⁾	Max. Input current ⁽¹⁾	Perm. ambient temp.	Weight	Techn. features and connection diagram
Type	Motor	VAC	Hz	rpm	kW	A	°C	kg		
*3G 630	M3G 150-IF	(A) 3~380-480	50/60	1275	2,67	4,10	-25..+40	32	P. 117 / RP2)	
*3G 630	M3G 150-NA	(B) 3~380-480	50/60	1530	4,68	7,20	-25..+40	39,5	P. 116 / RP1)	
*3G 630	M3G 200-HF	(C) 3~380-480	50/60	1750	7,06	10,8	-25..+40	97	P. 116 / RP1)	
*3G 630	M3G 200-LA	(D) 3~380-480	50/60	1950	9,78	15,2	-25..+40	116	P. 116 / RP1)	

Subject to change

(1) Nominal data at operating point with maximum load and 400 VAC.

Curves:

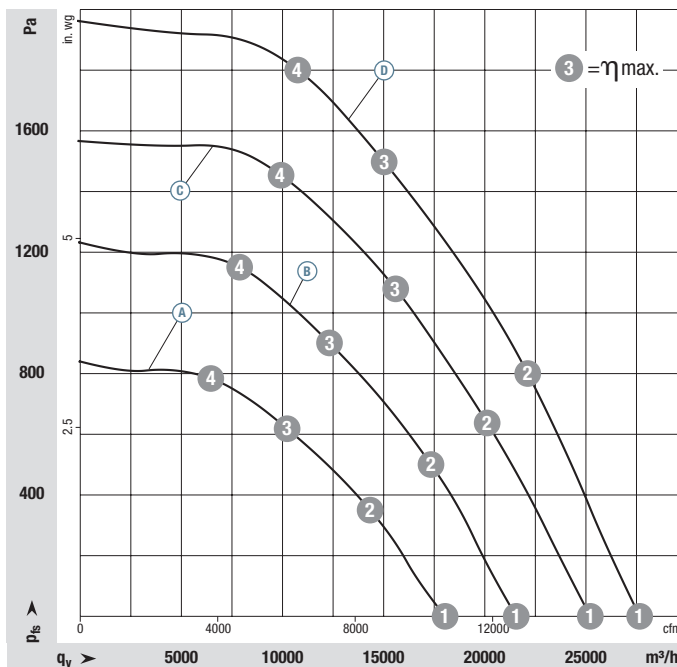

	n rpm	P _{ed} kW	I A	L _{wA} dB(A)
(A) ①	1275	1,42	2,28	90
(A) ②	1275	2,32	3,60	81
(A) ③	1275	2,67	4,10	78
(A) ④	1275	2,53	3,90	82
(B) ①	1530	2,51	4,00	93
(B) ②	1530	4,02	6,21	86
(B) ③	1530	4,68	7,20	82
(B) ④	1530	4,48	6,88	87
(C) ①	1750	3,74	5,89	99
(C) ②	1750	6,00	9,22	90
(C) ③	1750	7,06	11,80	86
(C) ④	1750	6,90	10,55	89
(D) ①	1950	5,08	8,40	105
(D) ②	1950	8,40	13,19	96
(D) ③	1950	9,78	15,20	89
(D) ④	1950	9,33	14,55	94

Air performance measured according to: ISO 5801, installation category A, with ebm-papst inlet ring without contact protection. Intake-side sound level: L_{wA} according to ISO 13347, L_{pA} measured at 1 m distance from fan axis. The values given are only applicable under the specified measuring conditions and may differ depending on the installation conditions. In the event of deviation from the standard configuration, the parameters must be checked in installed condition. See Page 126 ff. for detailed information.

- **Technical features:** See connection diagram P. 116 f.
- **EMC:** Ⓐ Interference emission according to EN 61000-6-3, except EN 61000-3-2 for professionally used equipment with a total rated power greater than 1 kW
Immunity to interference according to EN 61000-6-2
- **Touch current:** <= 3,5 mA according to IEC 60990 (measuring circuit Fig. 4)
- **Terminal box design:** electrical connection via terminal strip
- **Protection class:** I (with customer connection of protective earth)
- **Conformity with standards:** EN 61800-5-1, CE
- **Approvals:** C22.2 Nr.77 + CAN/CSA-E60730-1, UL 1004-7 + 60730
- **Efficiency:** Ecodesign EU regulation EU 327/2011



Weight centrifugal fan



Inlet ring with one pressure tap



Weight centrifugal module with support bracket



Weight centrifugal module with cube design

Centrifugal fan	kg	Inlet ring with one pressure tap	Centrifugal module with support bracket	kg	Centrifugal module with cube design	kg
R3G 630-PB32 -71	32,0	64040-2-4013	K3G 630-PB32 -71	57,9	---	---
R3G 630-PC08 -01	39,5	64040-2-4013	K3G 630-PC08 -01	67,0	---	---
---	---	---	---	---	K3G 630-PV04 -01	97
---	---	---	---	---	K3G 630-PW04 -01	116

EC centrifugal fans – RadiPac

backward curved, Ø 630



R3G 630-PB32-71 (Centrifugal fan)

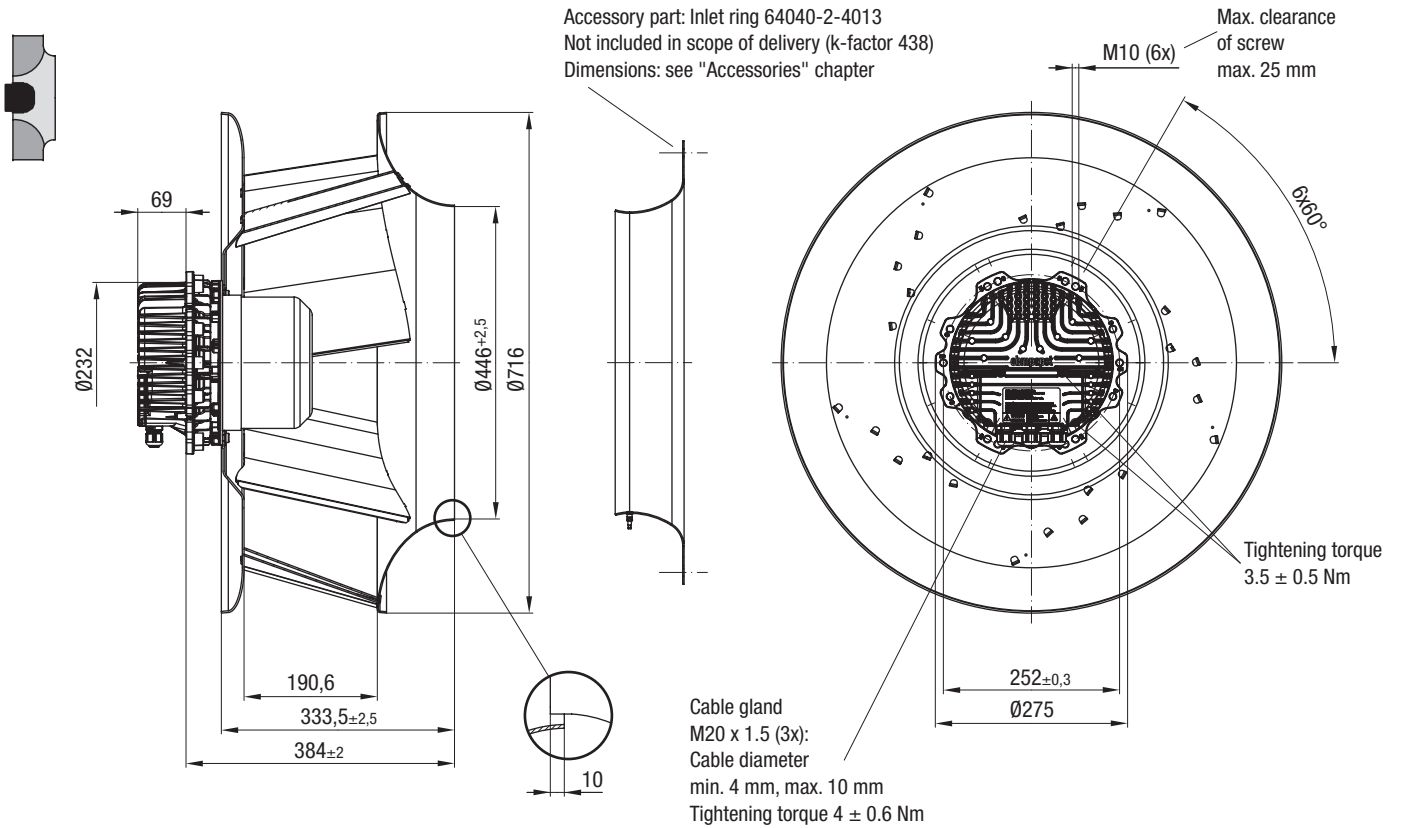

K3G 630-PB32-71 (Centrifugal module with support bracket)

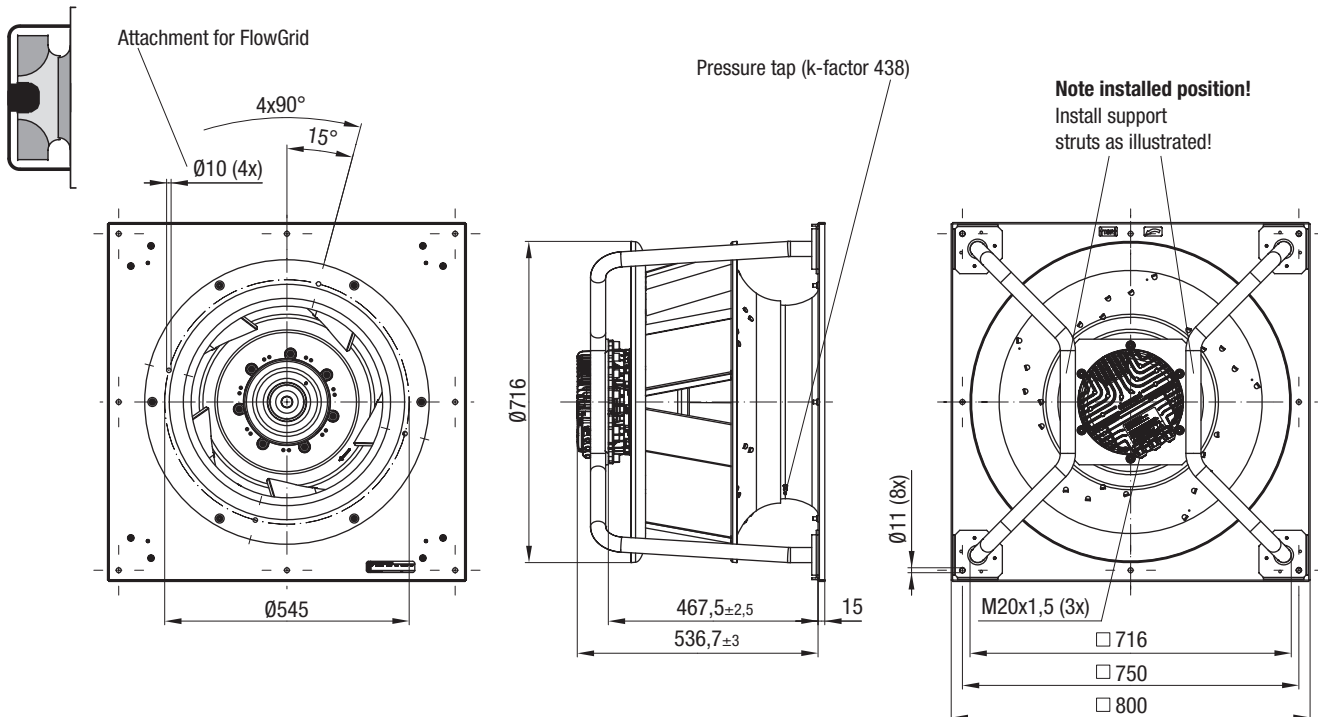

EC centrifugal fans – RadiPac

backward curved, Ø 630



R3G 630-PC08-01 (Centrifugal fan)

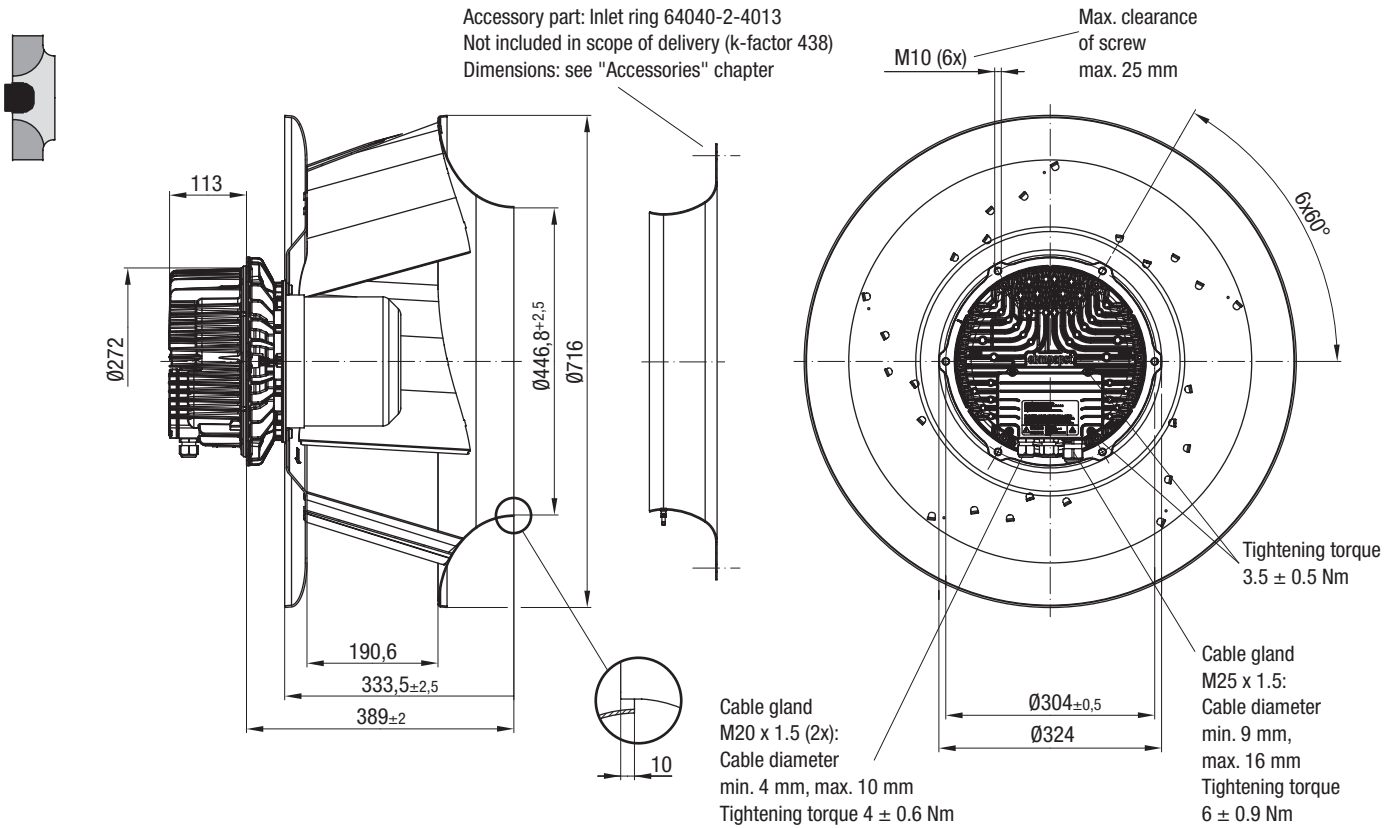

K3G 630-PC08-01 (Centrifugal module with support bracket)

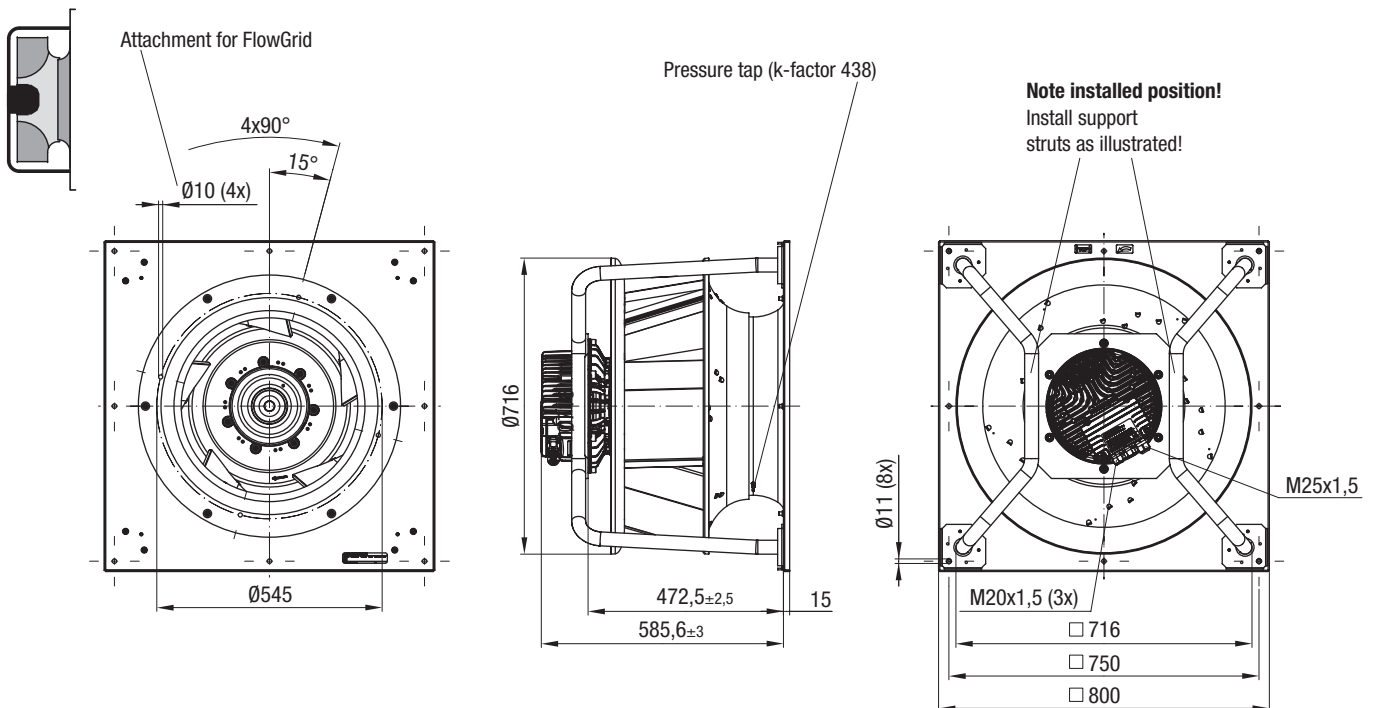

EC centrifugal fans – RadiPac

backward curved, Ø 630



K3G 630-PV04-01 (Centrifugal module with cube design)

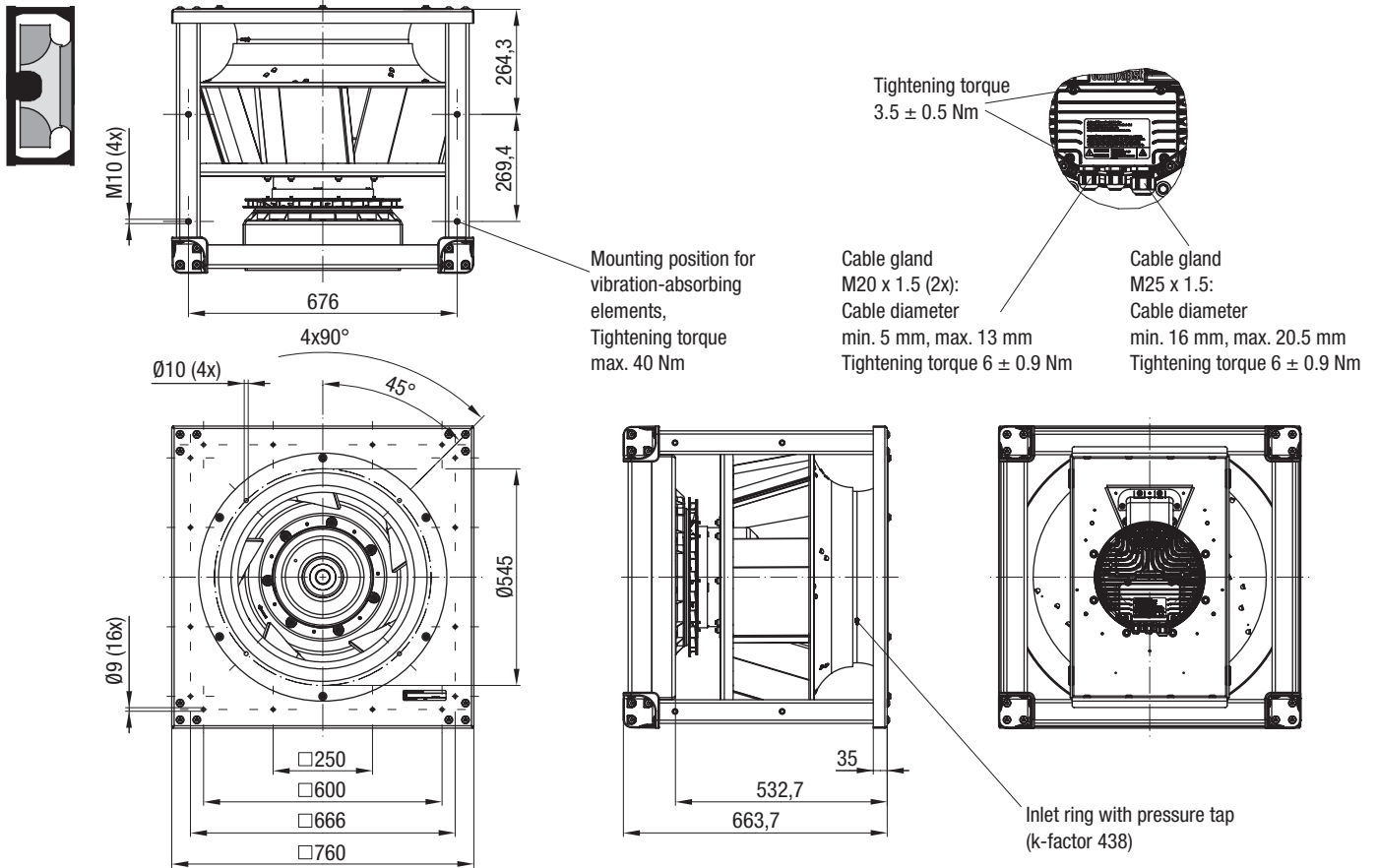

Note installation position: shaft horizontal (motor support plate must stand upright) or rotor on bottom; rotor on top on request!

EC centrifugal fans – RadiPac

backward curved, Ø 630



K3G 630-PW04-01 (Centrifugal module with cube design)

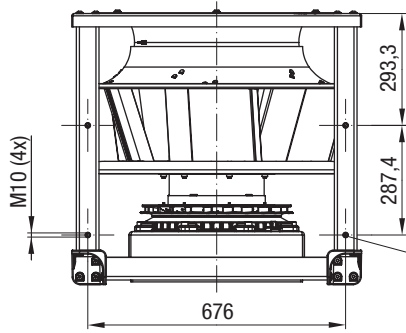

Mounting position for vibration-absorbing elements, Tightening torque max. 40 Nm

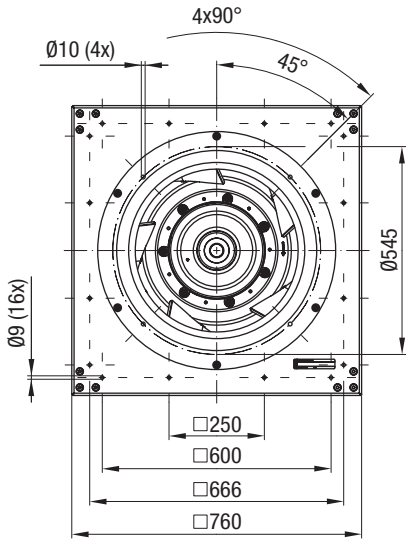

Tightening torque 3.5 ± 0.5 Nm

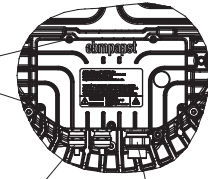

Cable gland M20 x 1.5 (2x): Cable diameter min. 5 mm, max. 13 mm Tightening torque 6 ± 0.9 Nm

Cable gland M25 x 1.5: Cable diameter min. 16 mm, max. 20.5 mm Tightening torque 6 ± 0.9 Nm

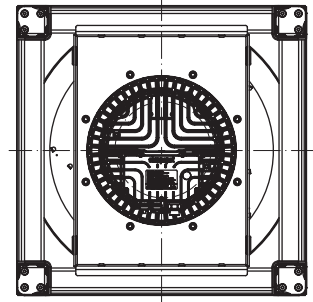
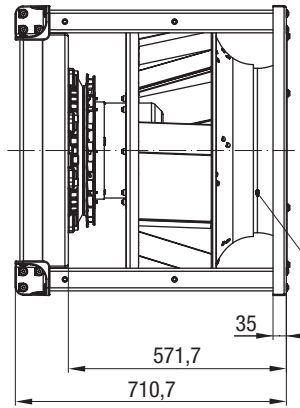

Inlet ring with pressure tap (k-factor 438)

Note installation position: shaft horizontal (motor support plate must stand upright) or rotor on bottom; rotor on top on request!

EC centrifugal fans – RadiPac

backward curved, Ø 710

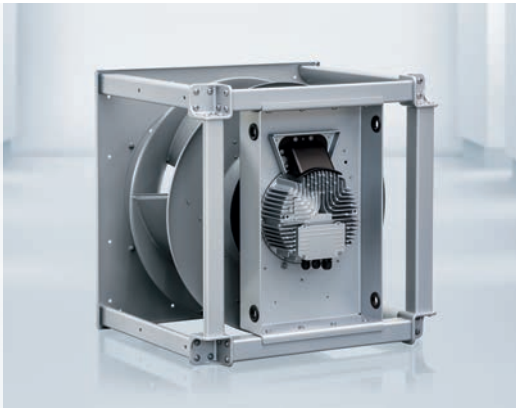

- **Material:** Support plate and inlet ring: Sheet steel, galvanized
 - Ⓐ Support bracket: Steel, painted black
 - Ⓑ Ⓒ Cube design, Spacer: Aluminium
- Impeller: Sheet aluminium; Rotor: Painted black
- Electronics housing: Die-cast aluminium
- **Number of blades:** 5
- **Direction of rotation:** Clockwise viewed toward rotor
- **Degree of protection:** Ⓐ IP 55; Ⓑ Ⓒ IP 54
- **Insulation class:** "F"
- **Installation position:** Shaft horizontal (Ⓑ Ⓒ base mounting only) or rotor on bottom, rotor on top on request
- **Condensation drainage holes:** Rotor side
- **Mode:** Continuous operation (S1)
- **Mounting:** Maintenance-free ball bearings

Nominal data

Type	Motor	Curve	Nominal voltage range	Frequency	Speed ⁽¹⁾	Max. Input power ⁽¹⁾	Max. Input current ⁽¹⁾	Perm. ambient temp.	Weight	Techn. features and connection diagram
Type	Motor	VAC	Hz	rpm	kW	A	°C	kg		
*3G 710	M3G 150-NA	Ⓐ	3~380-480	50/60	1060	2,90	4,50	-25..+40	39	P. 117 / RP2)
*3G 710	M3G 200-LA	Ⓑ	3~380-480	50/60	1430	7,35	11,2	-25..+40	127	P. 116 / RP1)
*3G 710	M3G 200-QA	Ⓒ	3~380-480	50/60	1680	11,9	18,3	-25..+40	154	P. 116 / RP1)

Subject to change

(1) Nominal data at operating point with maximum load and 400 VAC.

Curves:

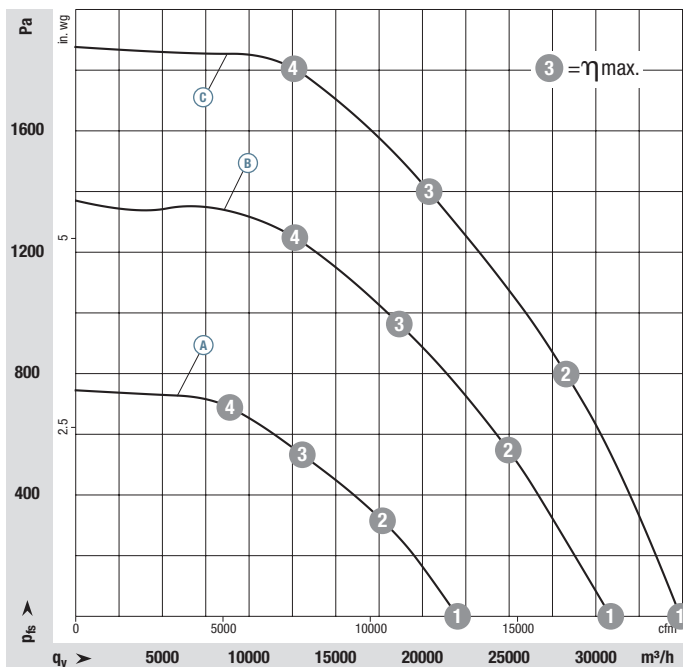

	n rpm	P _{ed} kW	I A	L _{wA} dB(A)
Ⓐ 1	1060	1,58	2,51	80
Ⓐ 2	1060	2,57	3,96	77
Ⓐ 3	1060	2,90	4,50	75
Ⓐ 4	1060	2,75	4,24	78
Ⓑ 1	1430	3,94	6,20	88
Ⓑ 2	1430	6,25	9,62	84
Ⓑ 3	1430	7,35	11,20	83
Ⓑ 4	1430	7,12	10,90	85
Ⓒ 1	1680	6,15	10,04	91
Ⓒ 2	1680	10,33	16,02	87
Ⓒ 3	1680	11,90	18,30	86
Ⓒ 4	1680	10,83	16,76	91

Air performance measured according to: ISO 5801, installation category A, with ebm-papst inlet ring without contact protection. Intake-side sound level: L_{wA} according to ISO 13347, L_{pA} measured at 1 m distance from fan axis. The values given are only applicable under the specified measuring conditions and may differ depending on the installation conditions. In the event of deviation from the standard configuration, the parameters must be checked in installed condition. See Page 126 ff. for detailed information.

- **Technical features:** See connection diagram P. 116 f.
- **EMC:** Interference emission according to EN 61000-6-4
Immunity to interference according to EN 61000-6-2
- **Touch current:** <= 3,5 mA according to IEC 60990 (measuring circuit Fig. 4)
- **Terminal box design:** electrical connection via terminal strip
- **Protection class:** I (with customer connection of protective earth)
- **Conformity with standards:** EN 61800-5-1, CE
- **Approvals:** ^A EAC
^B ^C C22.2 Nr.77 + CAN/CSA-E60730-1, UL 1004-7 + 60730
- **Efficiency:** Ecodesign EU regulation EU 327/2011



Weight centrifugal fan



Inlet ring with one pressure tap

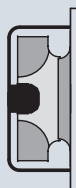

Weight centrifugal module with support bracket



Weight centrifugal module with cube design

Centrifugal fan	kg	Inlet ring with one pressure tap	Centrifugal module with support bracket	kg	Centrifugal module with cube design	kg
R3G 710-PC05 -71	39,0	71075-2-4013	K3G 710-PC05 -71	73,0	---	---
---	---	---	---	---	K3G 710-PV05 -01	127
---	---	---	---	---	K3G 710-PW06 -01	154

EC centrifugal fans – RadiPac

backward curved, Ø 710



R3G 710-PC05-71 (Centrifugal fan)

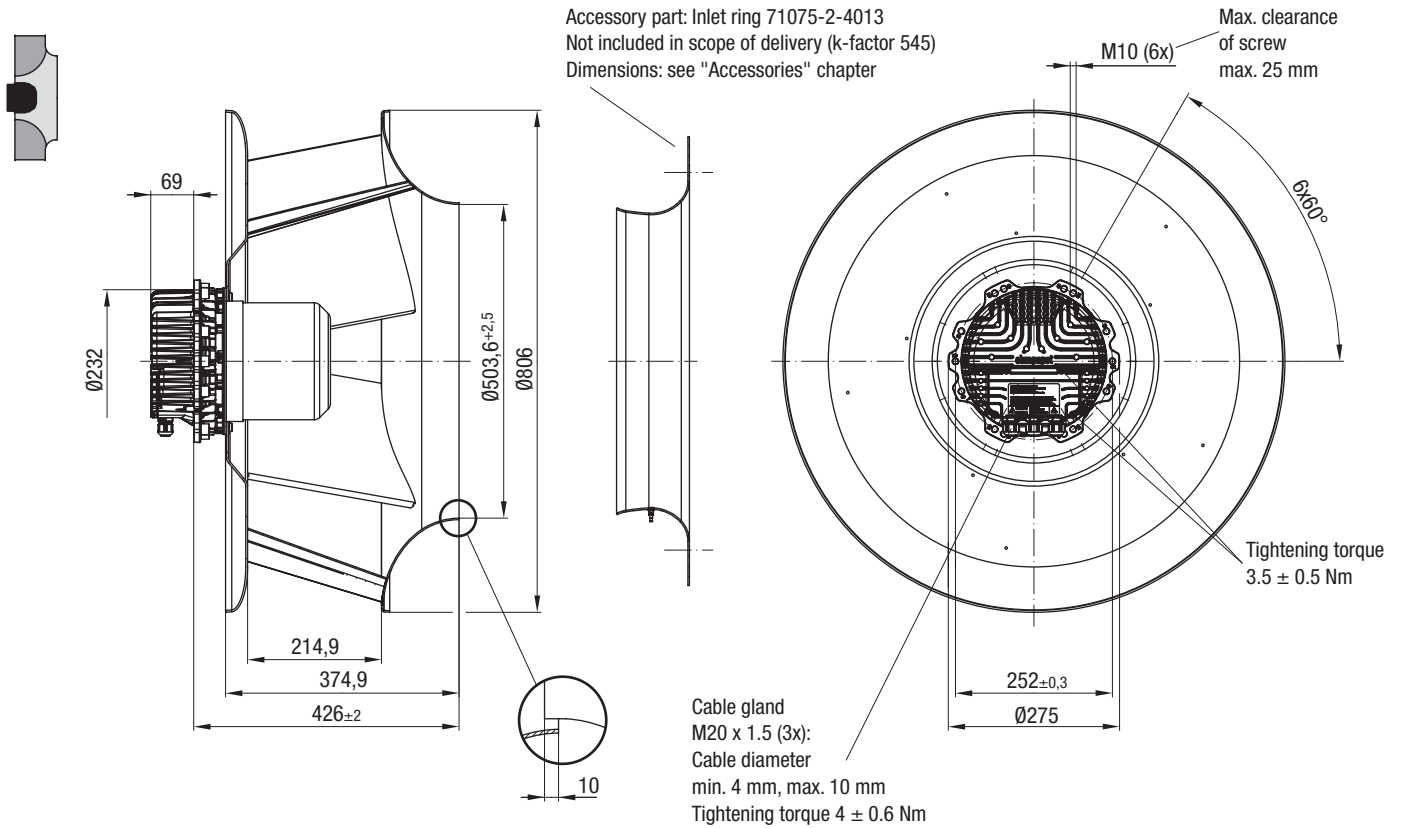

K3G 710-PC05-71 (Centrifugal module with support bracket)

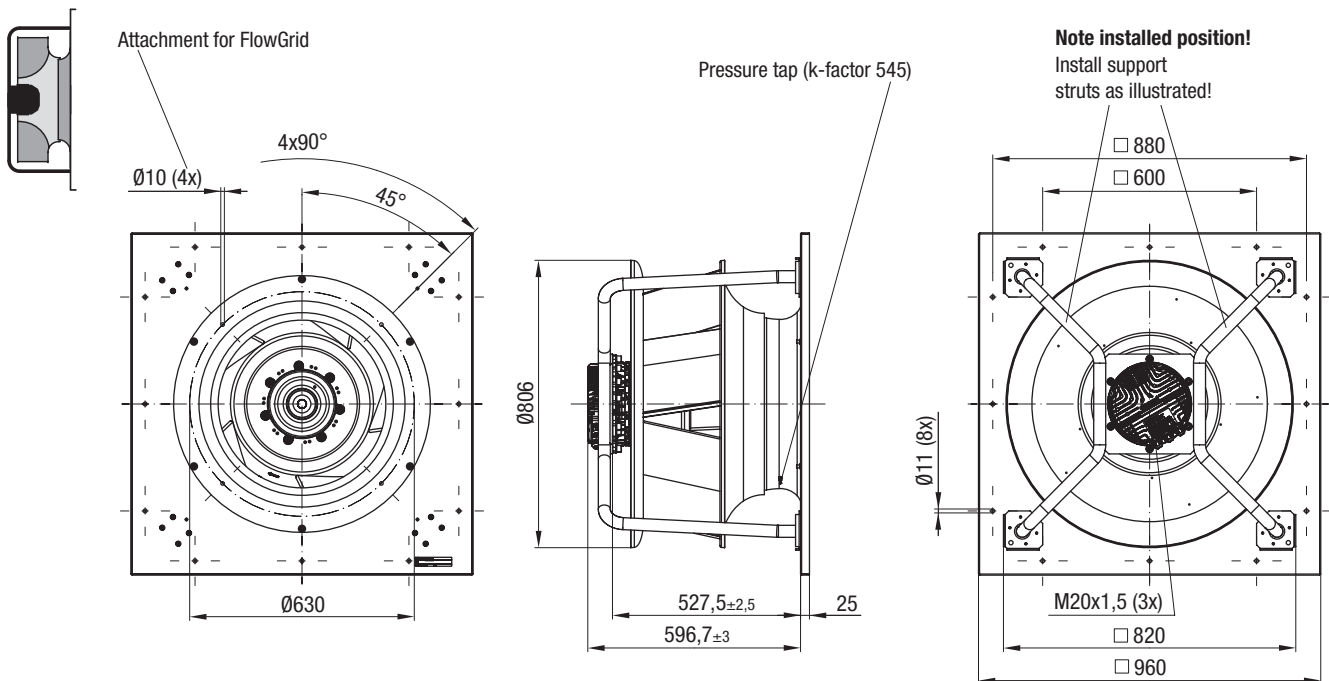

EC centrifugal fans – RadiPac

backward curved, Ø 710



Information

Ø 250

Ø 280

Ø 310

Ø 355

Ø 400

Ø 450

Ø 500

Ø 560

Ø 630

Ø 710

Ø 800

Ø 1000

Short version

Compact version

ATEX version

Technology

Agents

2017-07

K3G 710-PV05-01 (Centrifugal module with cube design)

Note installation position: shaft horizontal (motor support plate must stand upright) or rotor on bottom; rotor on top on request!

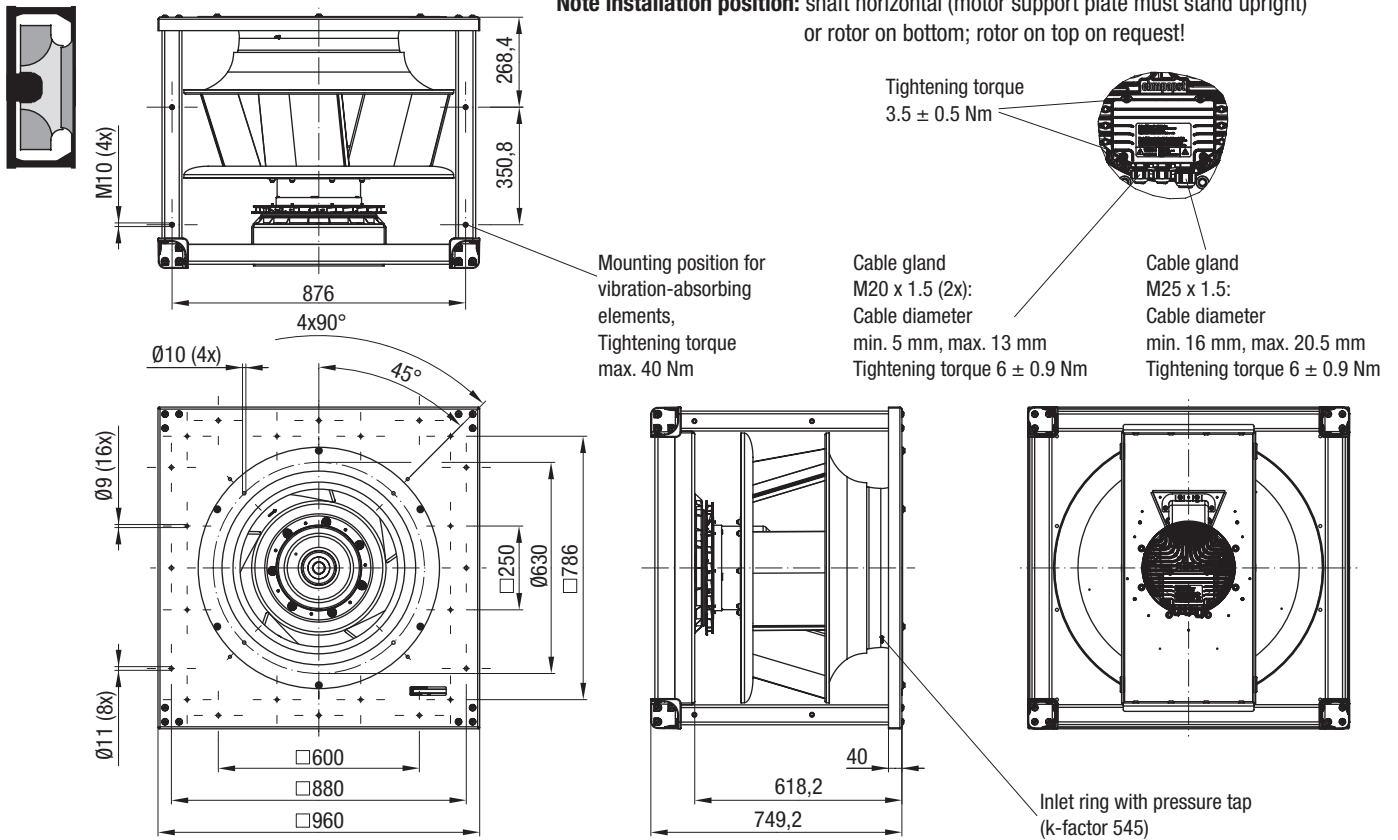

K3G 710-PW06-01 (Centrifugal module with cube design)

Note installation position: shaft horizontal (motor support plate must stand upright) or rotor on bottom; rotor on top on request!

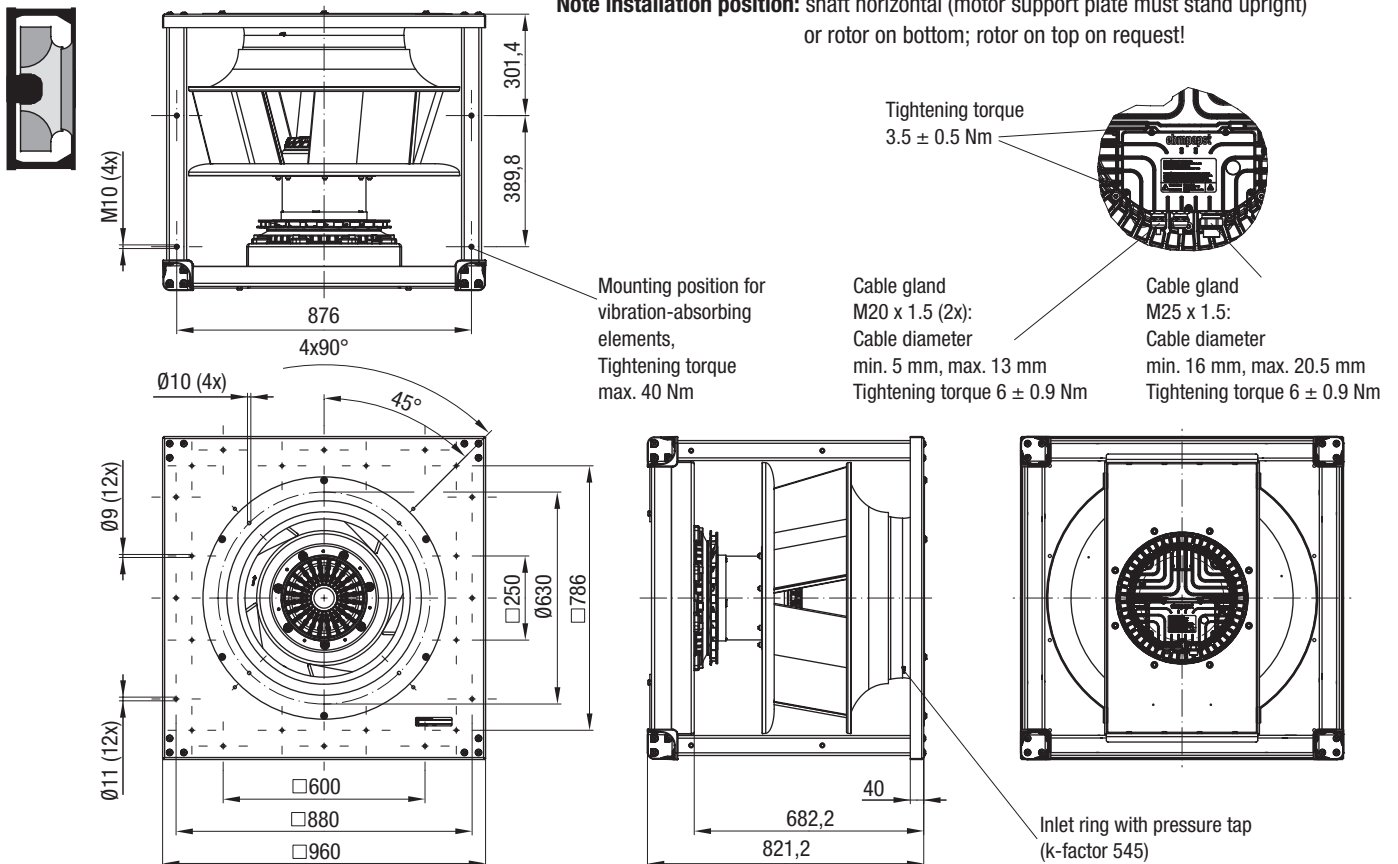

EC centrifugal fans – RadiPac

backward curved, Ø 800

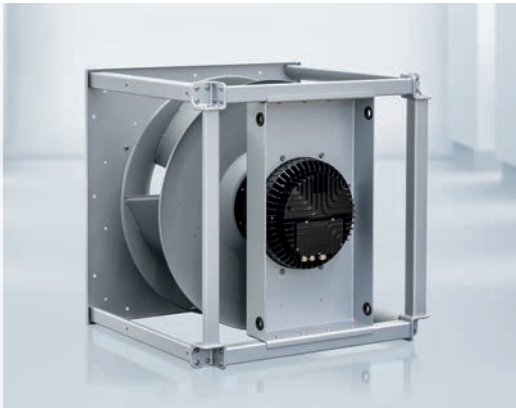

- **Material:** Support plate and inlet ring: Sheet steel, galvanized
 - Ⓐ Support bracket: Steel, painted black
 - Ⓑ Ⓒ Cube design, Spacer: Aluminium
- Impeller: Sheet aluminium; Rotor: Painted black
- Electronics housing: Die-cast aluminium
- **Number of blades:** 5
- **Direction of rotation:** Clockwise viewed toward rotor
- **Degree of protection:** Ⓐ IP 55; Ⓑ Ⓒ IP 54
- **Insulation class:** "F"
- **Installation position:** Shaft horizontal (Ⓑ Ⓒ base mounting only) or rotor on bottom, rotor on top on request
- **Condensation drainage holes:** Rotor side
- **Mode:** Continuous operation (S1)
- **Mounting:** Maintenance-free ball bearings

Nominal data

Type	Motor	Curve	Nominal voltage range	Frequency	Speed ⁽¹⁾	Max. Input power ⁽¹⁾	Max. Input current ⁽¹⁾	Perm. ambient temp.	Weight	Techn. features and connection diagram
Type	Motor	VAC	Hz	rpm	kW	A	°C	kg		
*3G 800	M3G 150-NA	Ⓐ 3~380-480	50/60	835	2,60	4,00	-25..+40	42	P. 117 / RP2)	
*3G 800	M3G 200-QA	Ⓑ 3~380-480	50/60	1215	7,95	12,1	-25..+40	146	P. 116 / RP1)	
*3G 800	M3G 200-QA	Ⓒ 3~380-480	50/60	1370	11,30	17,5	-25..+40	157	P. 116 / RP1)	

Subject to change

(1) Nominal data at operating point with maximum load and 400 VAC.

Curves:

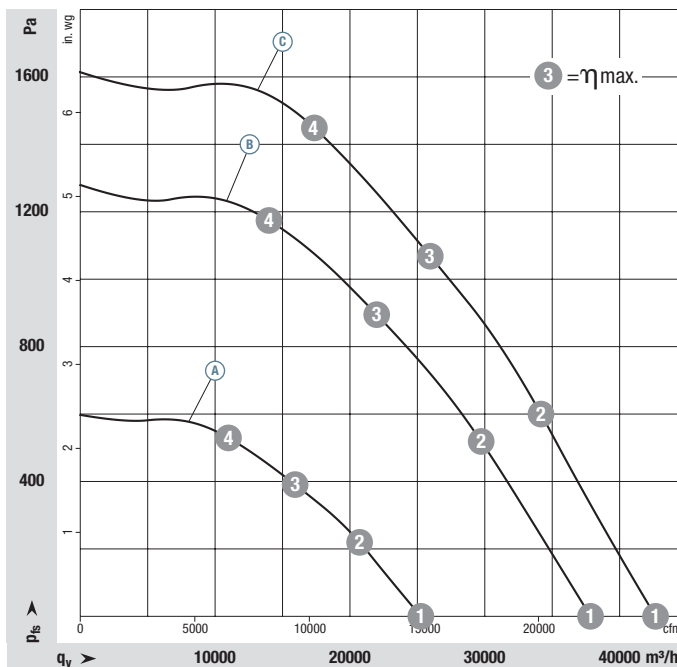

	n rpm	P _{ed} kW	I A	L _{wA} dB(A)
Ⓐ 1	835	1,43	2,30	79
Ⓐ 2	835	2,21	3,44	77
Ⓐ 3	835	2,60	4,00	75
Ⓐ 4	835	2,55	3,95	75
Ⓑ 1	1215	4,25	6,64	89
Ⓑ 2	1215	6,89	10,55	85
Ⓑ 3	1215	7,95	12,10	83
Ⓑ 4	1215	7,53	11,51	86
Ⓒ 1	1370	6,37	10,26	91
Ⓒ 2	1370	9,60	14,99	88
Ⓒ 3	1370	11,30	17,50	85
Ⓒ 4	1370	11,00	17,04	88

Air performance measured according to: ISO 5801, installation category A, with ebm-papst inlet ring without contact protection. Intake-side sound level: L_{wA} according to ISO 13347, L_{pA} measured at 1 m distance from fan axis. The values given are only applicable under the specified measuring conditions and may differ depending on the installation conditions. In the event of deviation from the standard configuration, the parameters must be checked in installed condition. See Page 126 ff. for detailed information.

- **Technical features:** See connection diagram P. 116 f.
- **Touch current:** <= 3,5 mA according to IEC 60990 (measuring circuit Fig. 4)
- **Terminal box design:** electrical connection via terminal strip
- **Protection class:** I (with customer connection of protective earth)
- **Conformity with standards:** EN 61800-5-1, CE
- **Approvals:** [Ⓐ] EAC
[Ⓑ] [Ⓒ] C22.2 Nr.77 + CAN/CSA-E60730-1, UL 1004-7 + 60730
- **Efficiency:** Ecodesign EU regulation EU 327/2011



Weight centrifugal fan



Inlet ring with one pressure tap



Weight centrifugal module with support bracket



Weight centrifugal module with cube design

Centrifugal fan	kg	Inlet ring with one pressure tap	Centrifugal module with support bracket	kg	Centrifugal module with cube design	kg
R3G 800-PC12 -71	42,0	80075-2-4013	K3G 800-PC12 -71	73,0	---	---
---	---	---	---	---	K3G 800-PV13 -01	146
---	---	---	---	---	K3G 800-PW07 -01	157

EC centrifugal fans – RadiPac

backward curved, Ø 800



R3G 800-PC12-71 (Centrifugal fan)

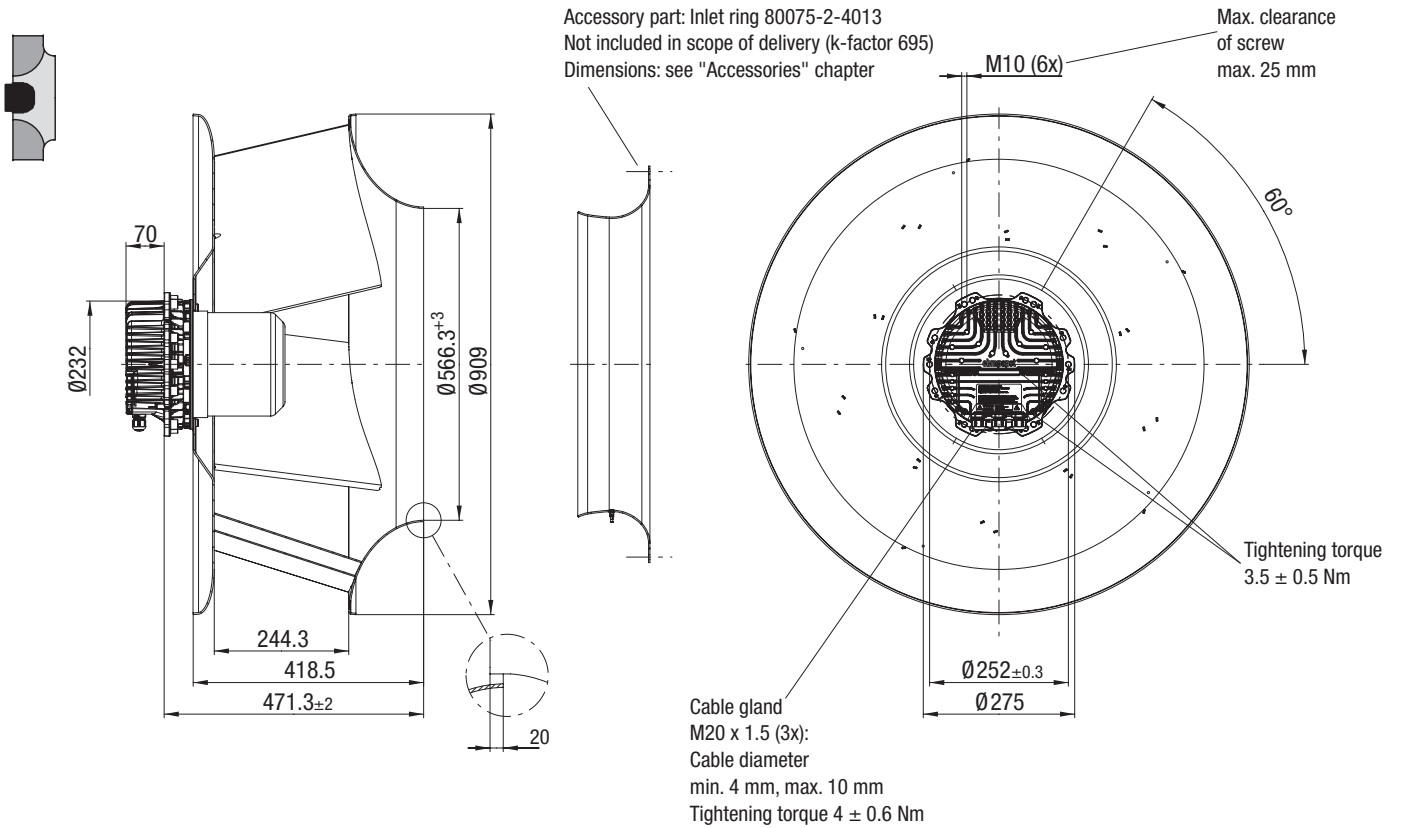

K3G 800-PC12-71 (Centrifugal module with support bracket)

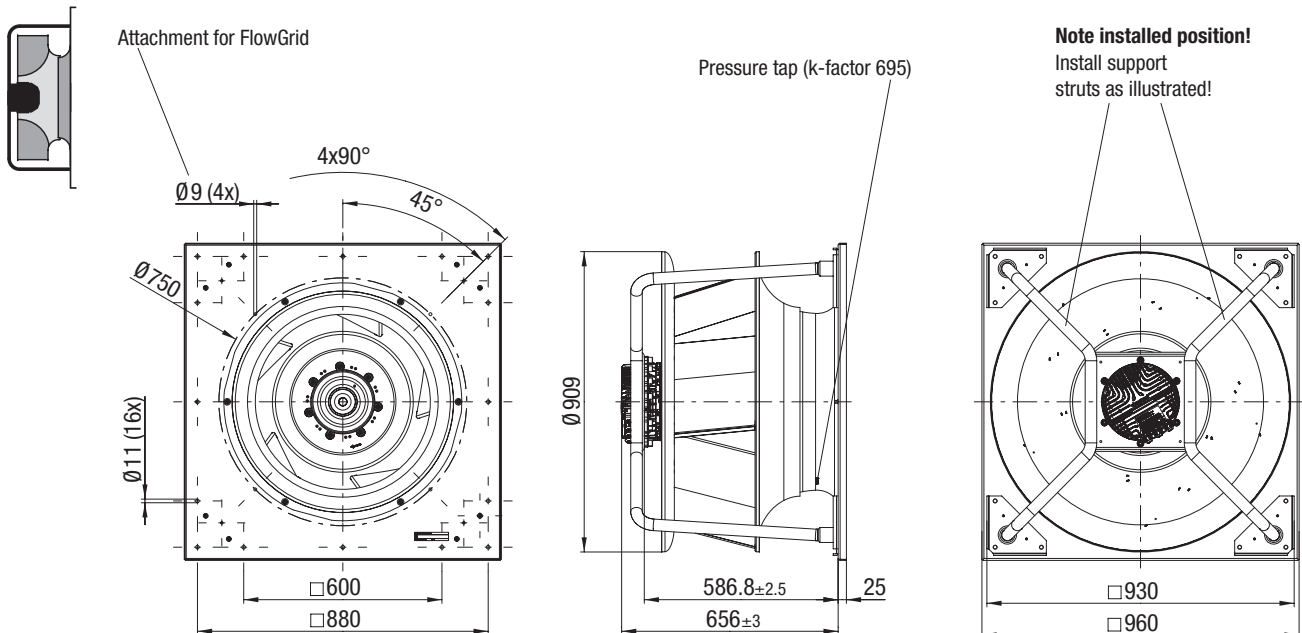

EC centrifugal fans – RadiPac

backward curved, Ø 800



Information

Ø 250

Ø 280

Ø 310

Ø 355

Ø 400

Ø 450

Ø 500

Ø 560

Ø 630

Ø 710

Ø 800

Ø 1000

Short version

Compact version

ATEX version

Technology

Agents

2017-07

K3G 800-PV13-01 (Centrifugal module with cube design)

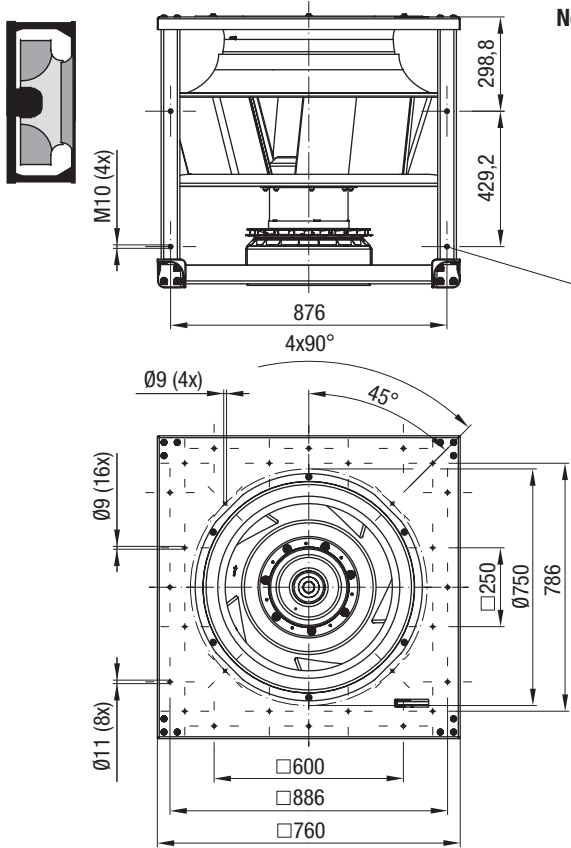

Note installation position: shaft horizontal (motor support plate must stand upright) or rotor on bottom; rotor on top on request!

Tightening torque
3.5 ± 0.5 Nm



Mounting position for vibration-absorbing elements, Tightening torque max. 40 Nm

Cable gland M20 x 1.5 (2x): Cable diameter min. 5 mm, max. 13 mm Tightening torque 6 ± 0.9 Nm

Cable gland M25 x 1.5: Cable diameter min. 16 mm, max. 20.5 mm Tightening torque 6 ± 0.9 Nm

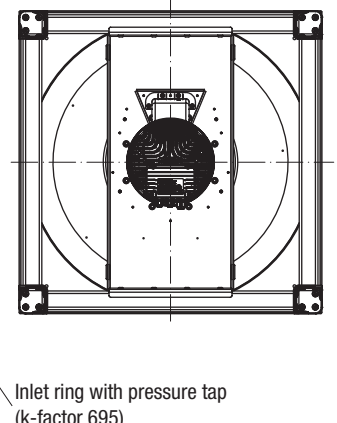
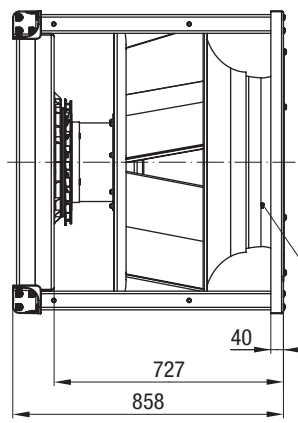

Inlet ring with pressure tap (k-factor 695)

K3G 800-PW07-01 (Centrifugal module with cube design)

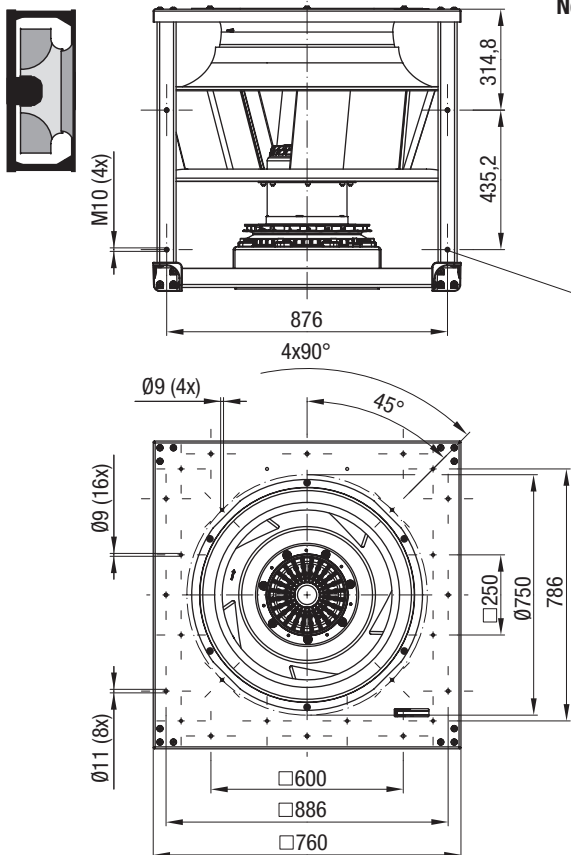

Note installation position: shaft horizontal (motor support plate must stand upright) or rotor on bottom; rotor on top on request!

Tightening torque
3.5 ± 0.5 Nm

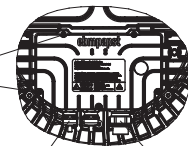

Mounting position for vibration-absorbing elements, Tightening torque max. 40 Nm

Cable gland M20 x 1.5 (2x): Cable diameter min. 5 mm, max. 13 mm Tightening torque 6 ± 0.9 Nm

Cable gland M25 x 1.5: Cable diameter min. 16 mm, max. 20.5 mm Tightening torque 6 ± 0.9 Nm

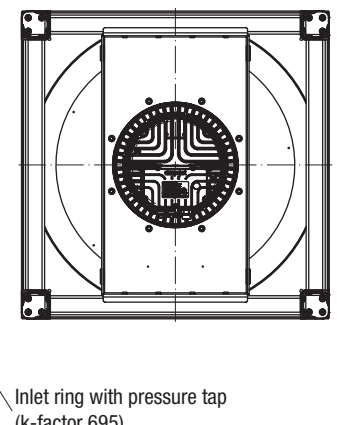
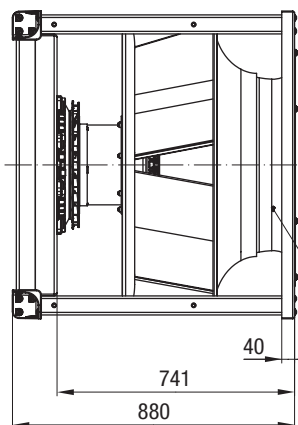

Inlet ring with pressure tap (k-factor 695)

EC centrifugal fans – RadiPac

backward curved, Ø 1000

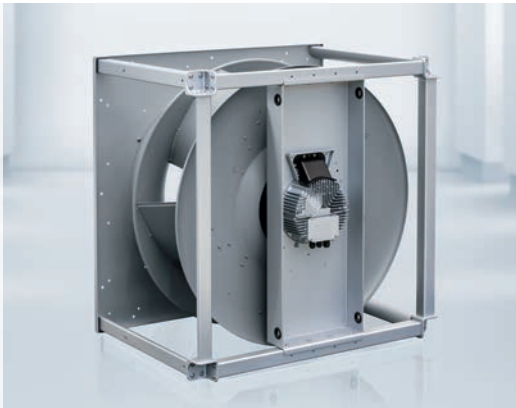

- **Material:** Support plate and inlet ring: Sheet steel, galvanized
Cube design, Spacer: Aluminium
Impeller: Sheet aluminium; Rotor: Painted black
Electronics housing: Die-cast aluminium
- **Number of blades:** 5
- **Direction of rotation:** Clockwise viewed toward rotor
- **Degree of protection:** IP 54
- **Insulation class:** "F"
- **Installation position:** Shaft horizontal (base mounting only) or rotor on bottom,
- **Condensation drainage holes:** Rotor side
- **Mode:** Continuous operation (S1)
- **Mounting:** Maintenance-free ball bearings

Nominal data

Type	Motor	Curve	Nominal voltage range	Frequency	Speed ⁽¹⁾	Max. Input power ⁽¹⁾	Max. Input current ⁽¹⁾	Perm. ambient temp.	Weight	Techn. features and connection diagram
		VAC	Hz	rpm	kW	A	°C	kg		
K3G A00-PV03 -01	M3G 200-QA	Ⓐ 3~380-480	50/60	750	6,34	9,80	-25..+40	178	P. 116 / RP1)	

Subject to change

(1) Nominal data at operating point with maximum load and 400 VAC.

Curves:

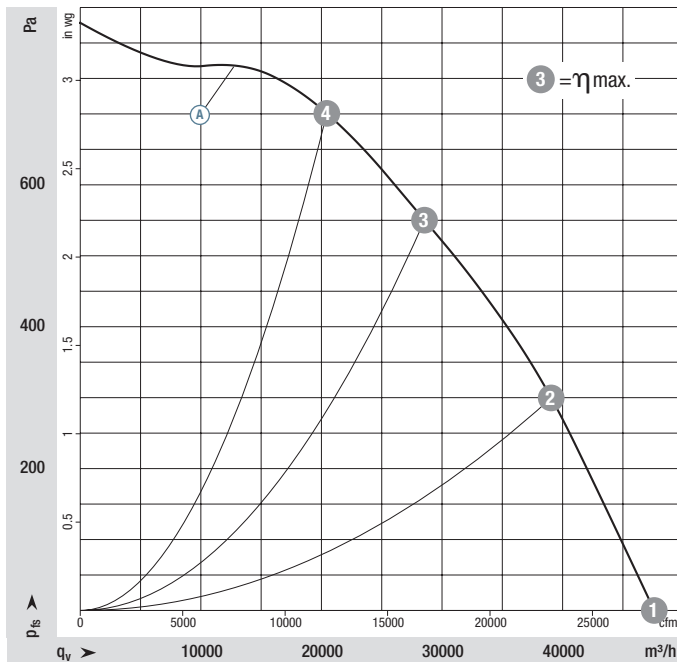

	n rpm	P _{ed} kW	I A	L _{wA} dB(A)
Ⓐ 1	750	3,54	5,63	84
Ⓐ 2	750	5,49	8,49	80
Ⓐ 3	750	6,34	9,80	77
Ⓐ 4	750	6,12	9,40	79

Air performance measured according to: ISO 5801, installation category A, with ebm-papst inlet ring without contact protection. Intake-side sound level: L_{wA} according to ISO 13347, L_{pA} measured at 1 m distance from fan axis. The values given are only applicable under the specified measuring conditions and may differ depending on the installation conditions. In the event of deviation from the standard configuration, the parameters must be checked in installed condition. See Page 126 ff. for detailed information.

- **Technical features:** See connection diagram P. 116
- **Touch current:** $\leq 3,5$ mA according to IEC 60990 (measuring circuit Fig. 4)
- **Terminal box design:** electrical connection via terminal strip
- **Protection class:** I (with customer connection of protective earth)
- **Conformity with standards:** EN 61800-5-1, CE
- **Approvals:** C22.2 Nr.77 + CAN/CSA-E60730-1, UL 1004-7 + 60730
- **Efficiency:** Ecodesign EU regulation EU 327/2011

EC centrifugal fans – RadiPac

backward curved, Ø 1000



K3G A00-PV03-01 (Centrifugal module with cube design)

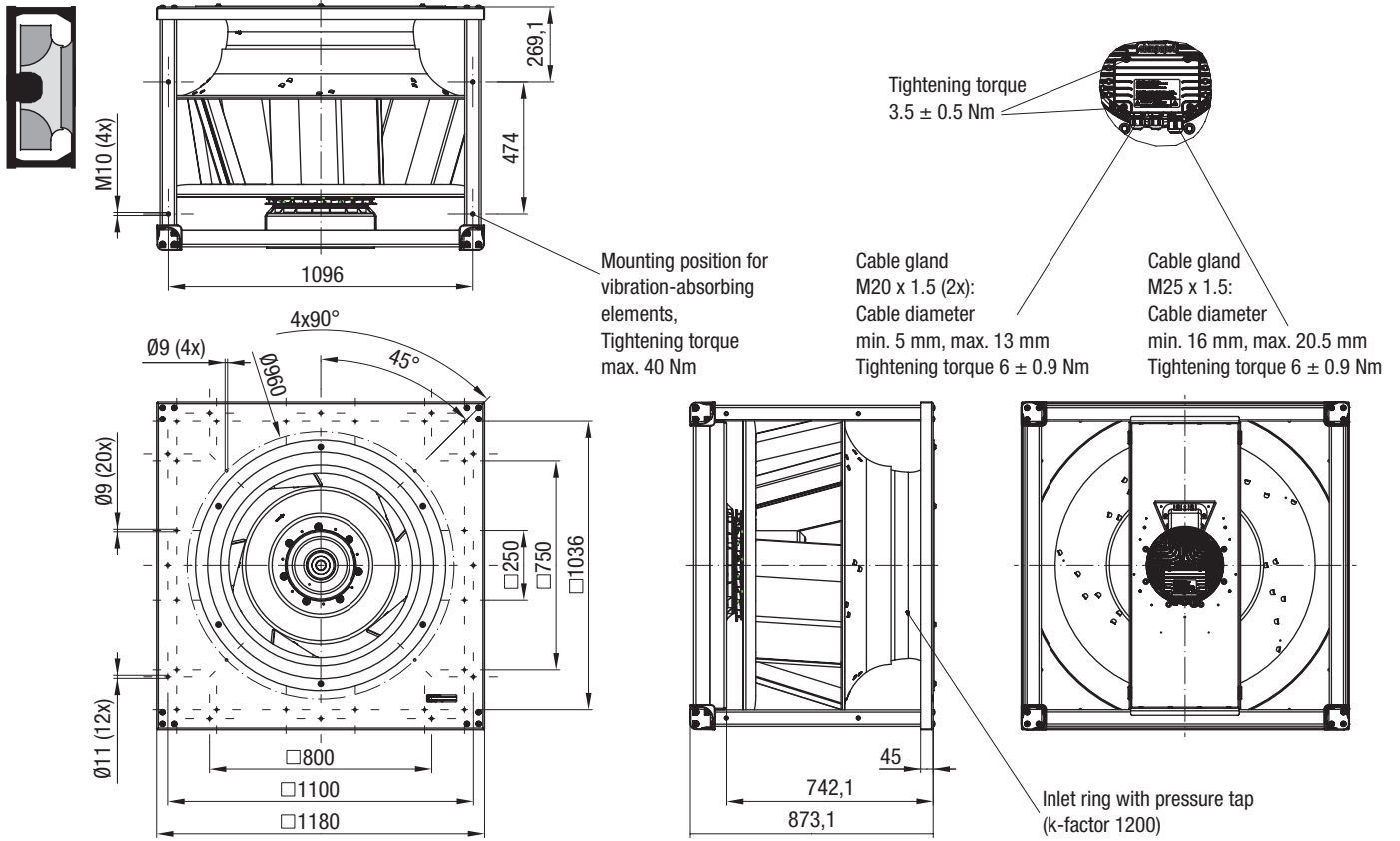

Note installation position: shaft horizontal (motor support plate must stand upright) or rotor on bottom; rotor on top on request!

Agents	Technology	ATEX version	Compact version	Short version	Ø 1000	Ø 800	Ø 710	Ø 630	Ø 560	Ø 500	Ø 450	Ø 400	Ø 355	Ø 310	Ø 280	Ø 250	Information
--------	------------	--------------	-----------------	---------------	--------	-------	-------	-------	-------	-------	-------	-------	-------	-------	-------	-------	-------------

Short version:

In addition to the standard versions, size 450, 500 and 560 RadiPac centrifugal fans in the R3G (motor impeller) and K3G (modular) design variants are also combined with the third-generation M3G 150 motor.

The result is a higher-performance version with additional functionality such as programmable inputs and outputs and an LED status indicator.

Moreover, mounting the impeller on the base flange results in a lower installed height.



EC centrifugal fans – RadiPac

Short version, Ø 450 - Ø 560



EC centrifugal fans – RadiPac

backward curved, Ø 450 - Ø 560 (Short version)

- **Material:** Support bracket: Steel, painted black
Support plate and inlet ring: Sheet steel, galvanized
Impeller: Sheet aluminium
Rotor: Painted black
Electronics housing: Die-cast aluminium
- **Number of blades:** 5
- **Direction of rotation:** Clockwise viewed toward rotor
- **Degree of protection:** IP 55
- **Insulation class:** "F"
- **Installation position:** Shaft horizontal or rotor on bottom, rotor on top on request
- **Condensation drainage holes:** Rotor side
- **Mode:** Continuous operation (S1)
- **Mounting:** Maintenance-free ball bearings



Nominal data

Type	Motor	Curve	Nominal voltage range	Frequency	Speed ⁽¹⁾	Max. Input power ⁽¹⁾	Max. Input current ⁽¹⁾	Perm. ambient temp.	Weight	Techn. features and connection diagram
Type	Motor	VAC	Hz	rpm	kW	A	°C	kg		
*3G 450	M3G 150-FF	Ⓐ	3~380-480	50/60	2480	4,50	6,80	-25..+40	21,3	P. 121 / RP6)
*3G 500	M3G 150-FF	Ⓑ	3~380-480	50/60	1890	3,80	5,90	-25..+40	22,2	P. 121 / RP6)
*3G 500	M3G 150-FF	Ⓒ	3~380-480	50/60	2000	4,20	6,40	-25..+45	26,6	P. 121 / RP6)
*3G 560	M3G 150-FF	Ⓓ	3~380-480	50/60	1700	4,40	6,60	-25..+40	27,8	P. 121 / RP6)

Subject to change

(1) Nominal data at operating point with maximum load and 400 VAC.

Curves:

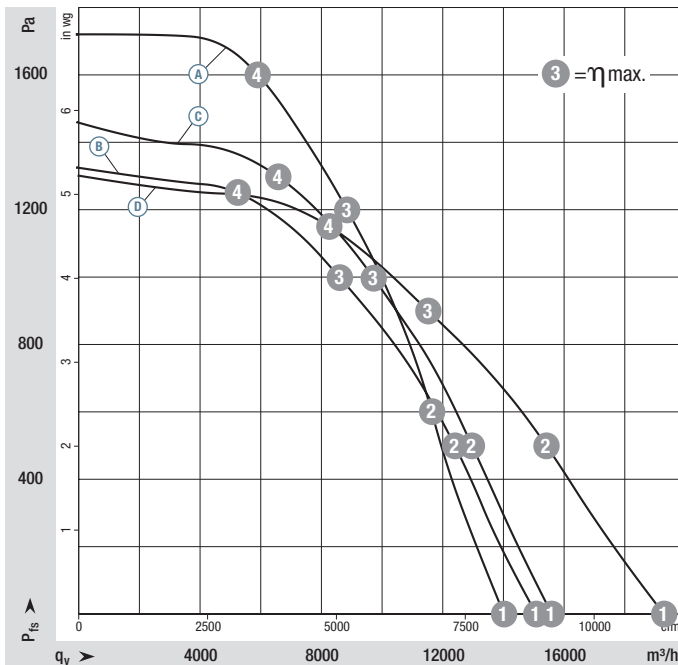

	n rpm	P _{ed} kW	I A	L _{wA} dB(A)
Ⓐ ①	2480	2,62	4,04	99
Ⓐ ②	2480	3,75	5,73	91
Ⓐ ③	2480	4,50	6,80	85
Ⓐ ④	2480	4,36	6,65	89
Ⓑ ①	1890	2,22	3,45	100
Ⓑ ②	1890	3,22	4,93	93
Ⓑ ③	1890	3,80	5,90	83
Ⓑ ④	1890	3,40	5,20	87
Ⓒ ①	2000	2,49	3,86	103
Ⓒ ②	2000	3,45	5,27	94
Ⓒ ③	2000	4,20	6,40	86
Ⓒ ④	2000	4,03	6,14	88
Ⓓ ①	1700	2,72	4,17	102
Ⓓ ②	1700	3,74	5,69	91
Ⓓ ③	1700	4,40	6,60	83
Ⓓ ④	1700	4,24	6,47	87

Air performance measured according to: ISO 5801, installation category A, with ebm-papst inlet ring without contact protection. Intake-side sound level: L_{wA} according to ISO 13347, L_{pA} measured at 1 m distance from fan axis. The values given are only applicable under the specified measuring conditions and may differ depending on the installation conditions. In the event of deviation from the standard configuration, the parameters must be checked in installed condition. See Page 126 ff. for detailed information.

- **Technical features:** See connection diagram P. 121
- **Touch current:** $\leq 3,5$ mA
- **Terminal box design:** electrical connection via terminal strip
- **Protection class:** I (with customer connection of protective earth)
- **Conformity with standards:** EN 61800-5-1, CE
- **Efficiency:** Ecodesign EU regulation EU 327/2011



Weight centrifugal fan

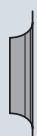

Inlet ring with one pressure tap



Weight centrifugal module with support bracket

Centrifugal fan	kg	Inlet ring with one pressure tap	Centrifugal module with support bracket	kg
R3G 450-PA31 -03	21,3	45075-2-4013	K3G 450-PA31 -03	38,0
R3G 500-PA28 -03	22,2	64025-2-4013	K3G 500-PA28 -03	38,9
R3G 500-PB24 -03	26,6	64025-2-4013	K3G 500-PB24 -03	43,3
R3G 560-PB31 -03	27,8	64030-2-4013	K3G 560-PB31 -03	53,3

EC centrifugal fans – RadiPac

backward curved, Ø 450 (Short version)

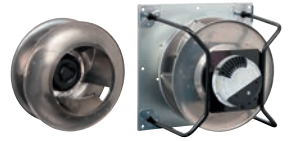

R3G 450-PA31-03 (Centrifugal fan)

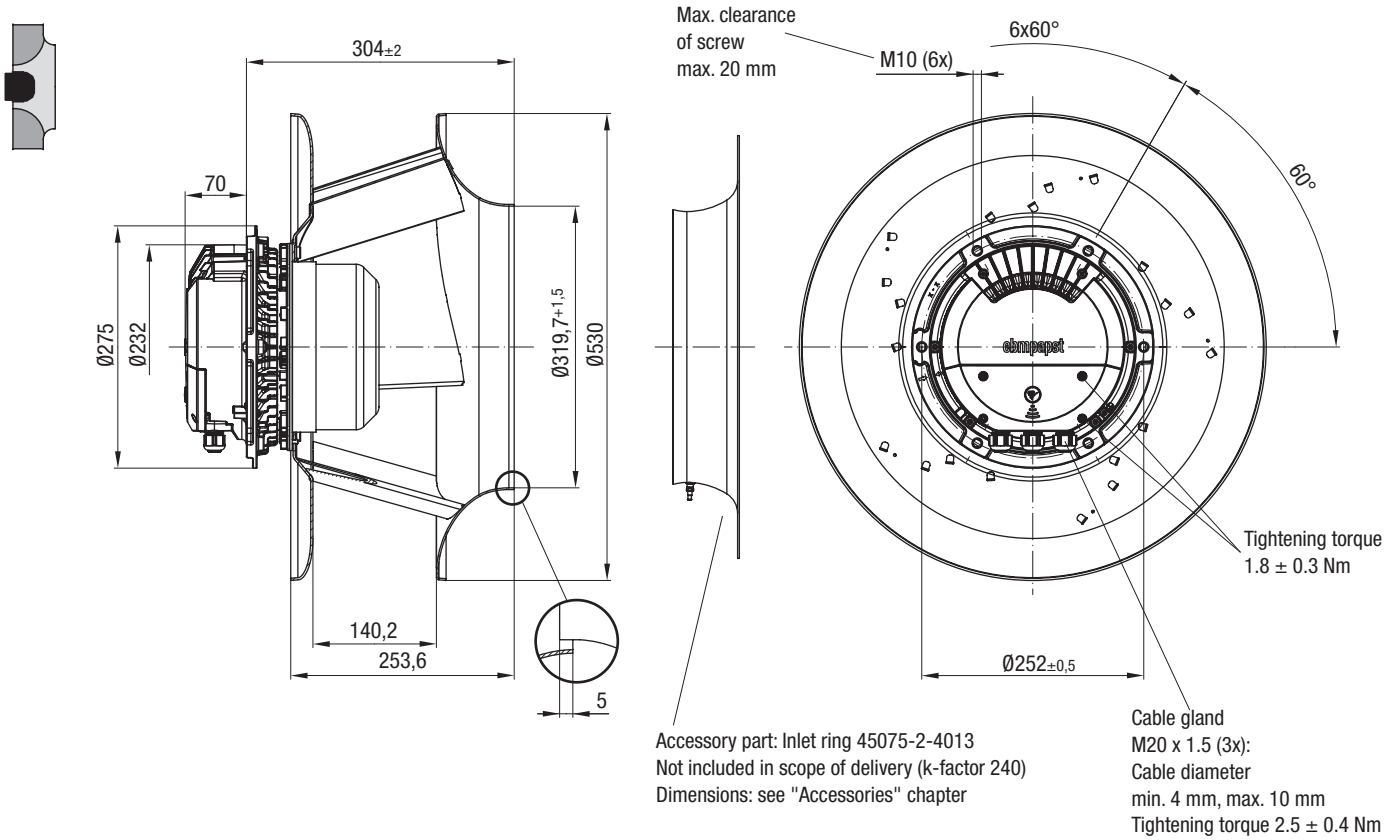

K3G 450-PA31-03 (Centrifugal module with support bracket)

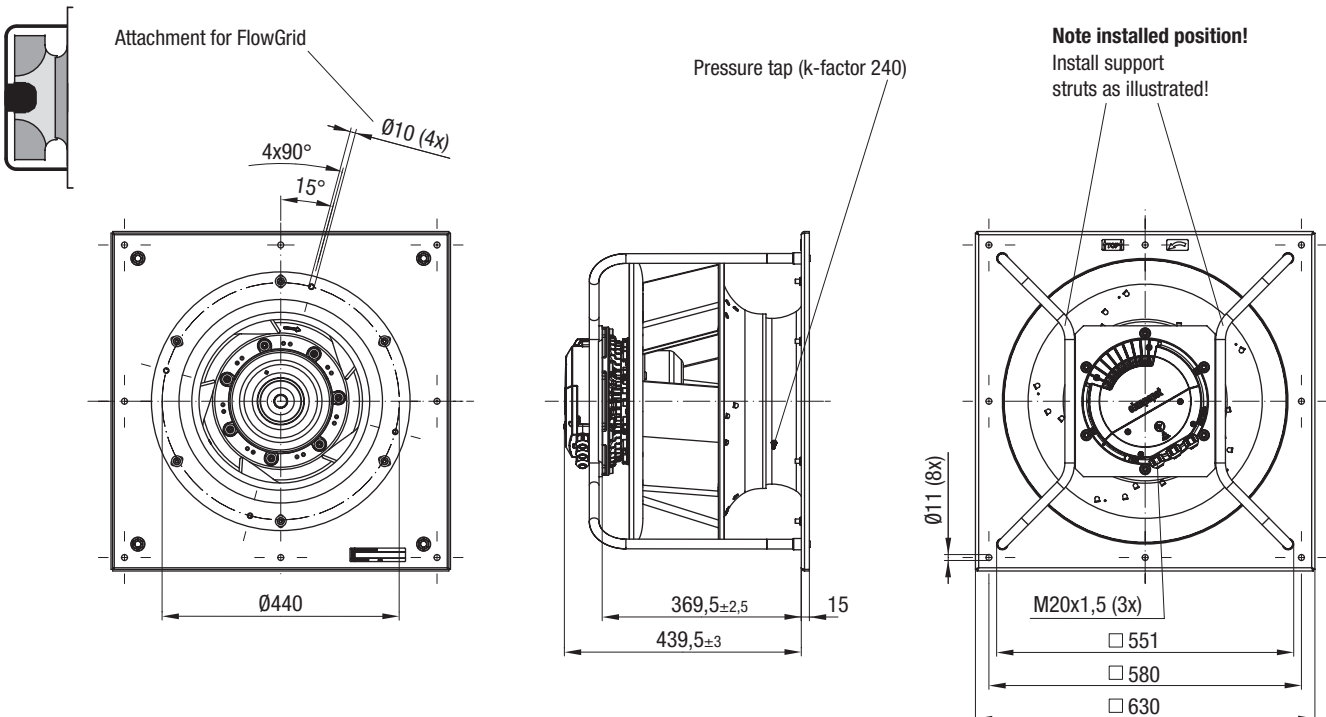

EC centrifugal fans – RadiPac

backward curved, Ø 500 (Short version)

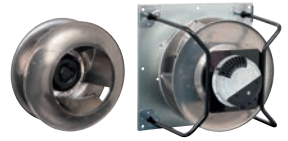

Information

Ø 250

Ø 280

Ø 310

Ø 355

Ø 400

Ø 450

Ø 500

Ø 560

Ø 630

Ø 710

Ø 800

Ø 1000

Short version

Compact version

ATEX version

Technology

Agents

2017-07

R3G 500-PA28-03 (Centrifugal fan)

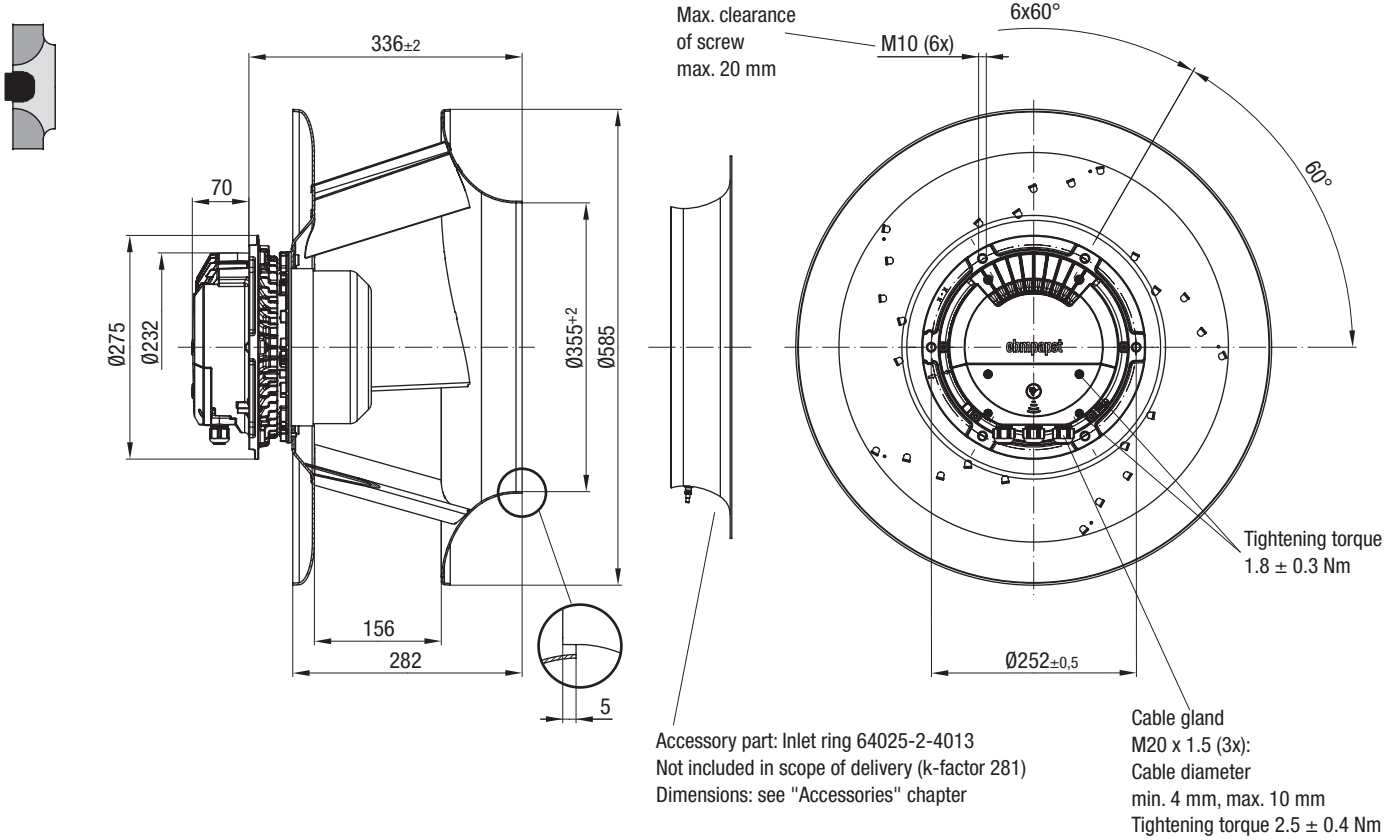

K3G 500-PA28-03 (Centrifugal module with support bracket)

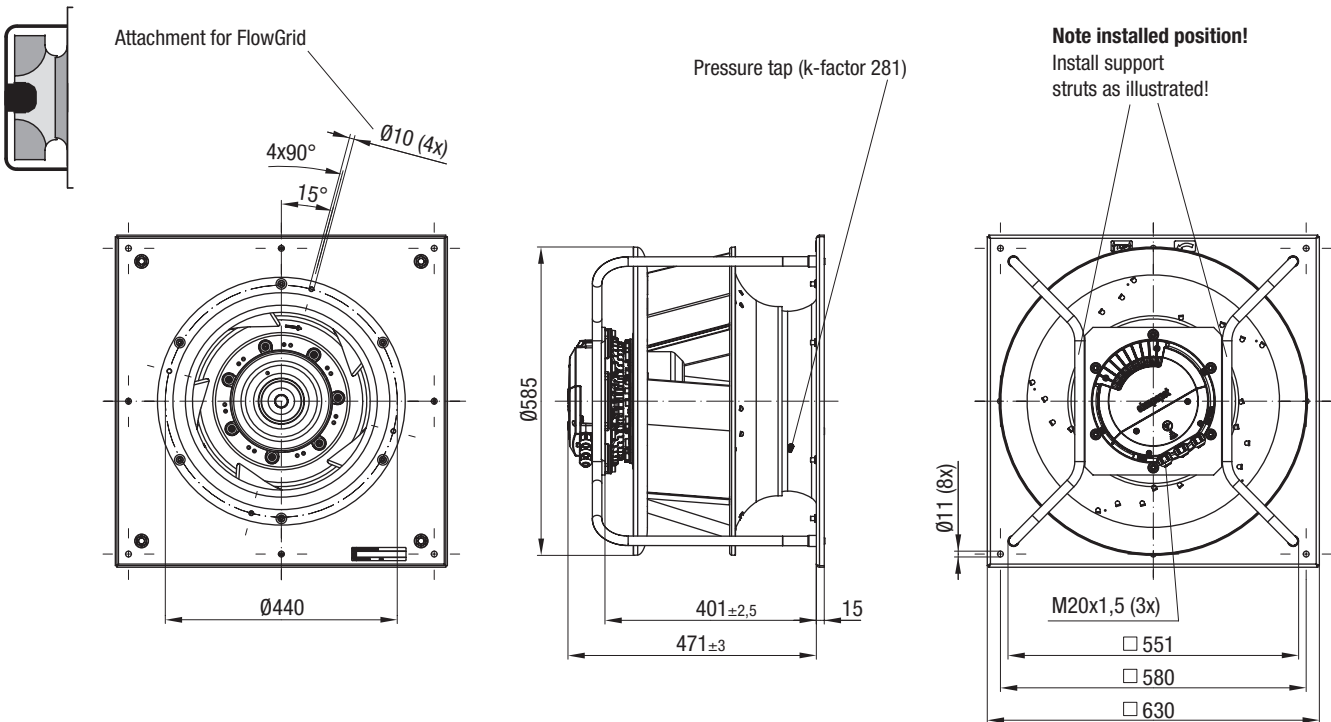

EC centrifugal fans – RadiPac

backward curved, Ø 500 (Short version)



R3G 500-PB24-03 (Centrifugal fan)

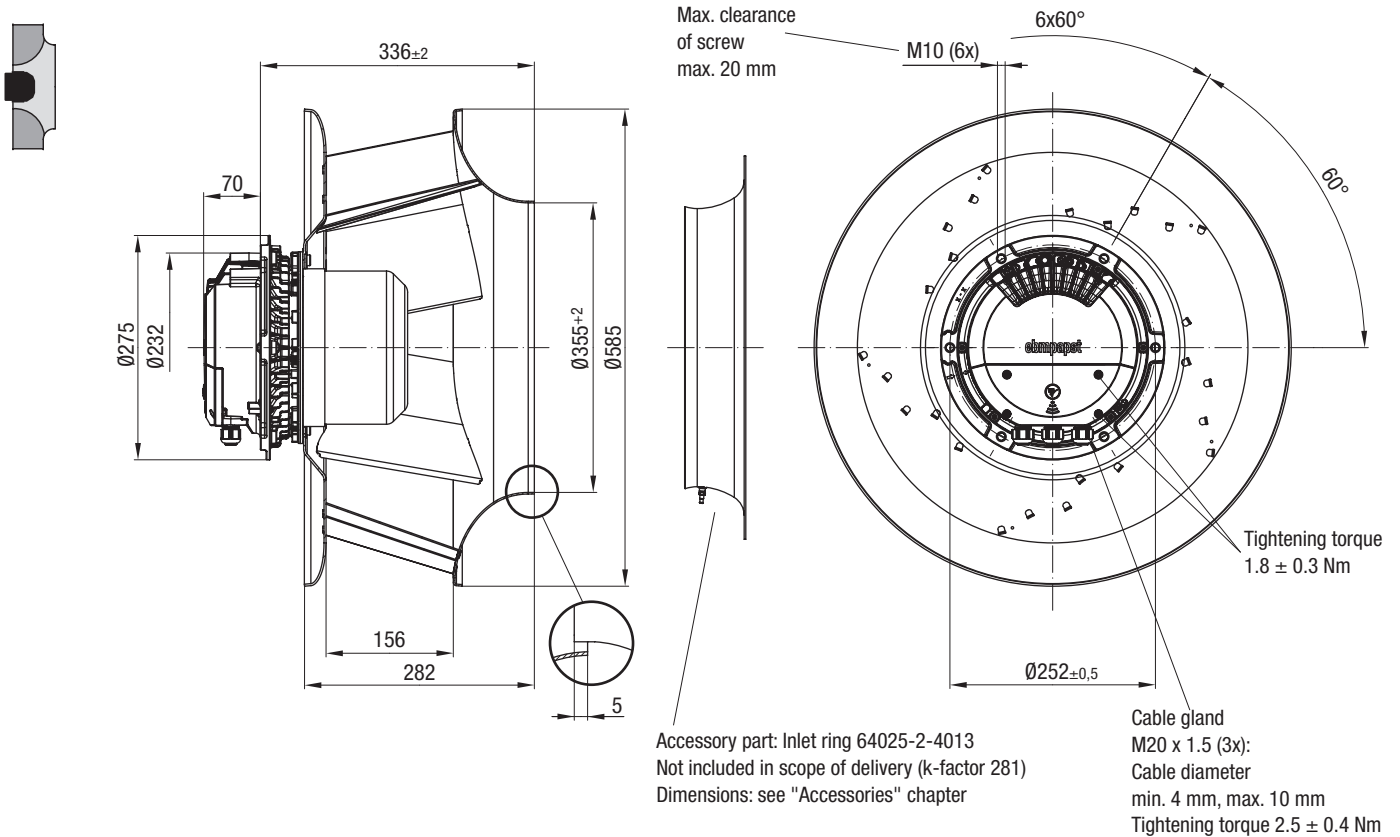

K3G 500-PB24-03 (Centrifugal module with support bracket)

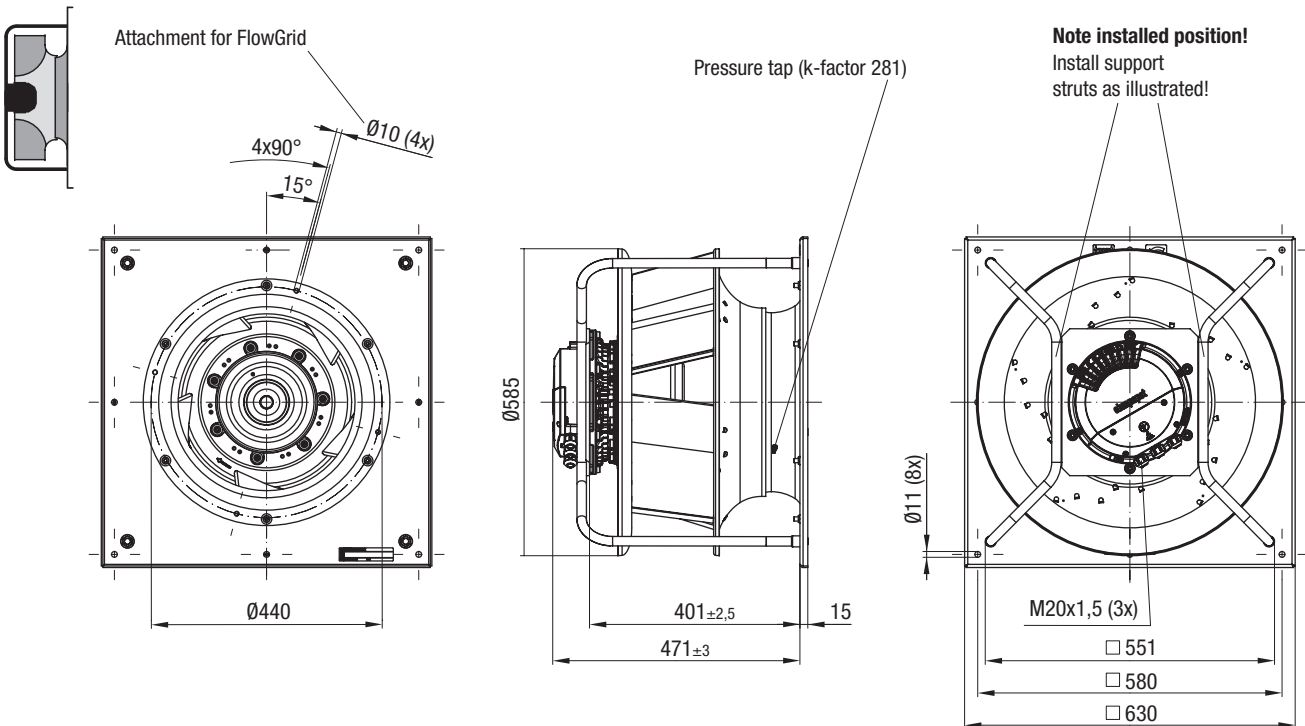

EC centrifugal fans – RadiPac

backward curved, Ø 560 (Short version)

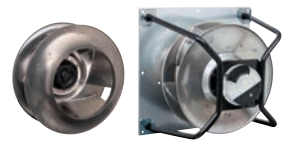

Information

Ø 250

Ø 280

Ø 310

Ø 355

Ø 400

Ø 450

Ø 500

Ø 560

Ø 630

Ø 710

Ø 800

Ø 1000

Short version

Compact version

ATEX version

Technology

Agents

2017-07

R3G 560-PB31-03 (Centrifugal fan)

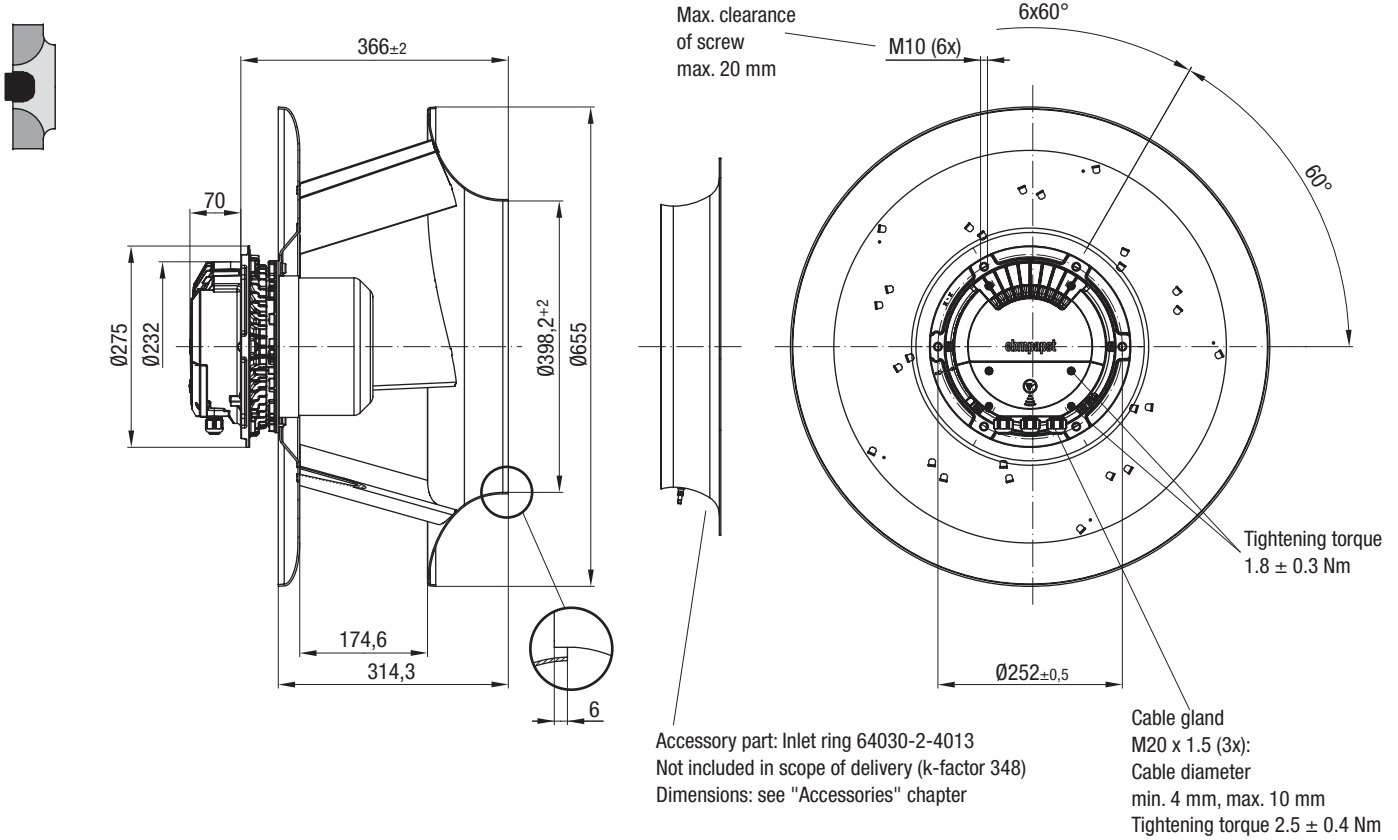

K3G 560-PB31-03 (Centrifugal module with support bracket)

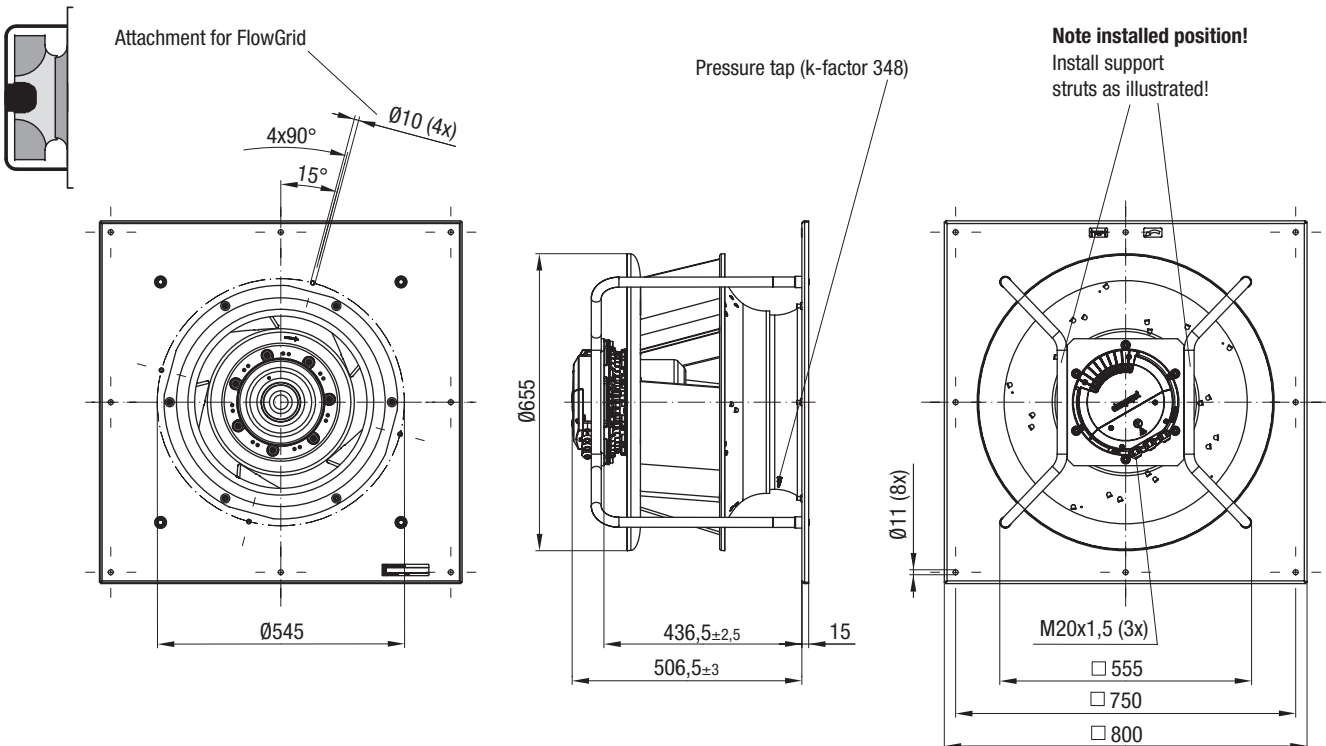

Compact version:

RadiPac centrifugal fans in sizes 280 to 450 are also available as compact R3G motor impellers.

The aluminum impeller without airfoil blades and without radial diffuser has a very small footprint and is intended for use in single-inlet scroll or half-scroll housings.

EC centrifugal fans – RadiPac

Compact version, Ø 280 - Ø 450



Information

Ø 250

Ø 280

Ø 310

Ø 355

Ø 400

Ø 450

Ø 500

Ø 560

Ø 630

Ø 710

Ø 800

Ø 1000

Short version

Compact version

ATEX version

Technology

Agents

EC centrifugal fans – RadiPac

backward curved, Ø 280 - 450 (Compact version)

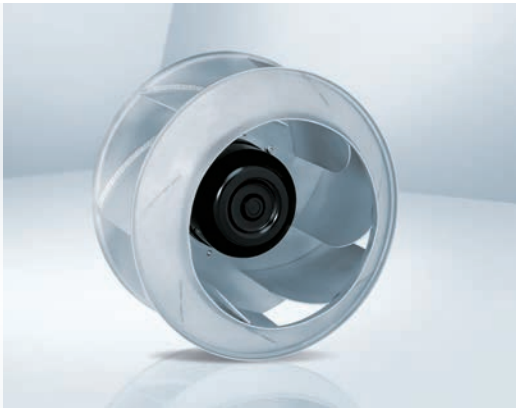

- **Material:** Impeller: Sheet aluminium
Rotor: Painted black
Electronics housing: Die-cast aluminium
- **Number of blades:** 7
- **Direction of rotation:** Clockwise viewed toward rotor
- **Degree of protection:** IP 54
- **Insulation class:** "B"
- **Installation position:** Shaft horizontal or rotor on bottom, rotor on top on request
- **Condensation drainage holes:** Rotor side
- **Mode:** Continuous operation (S1)
- **Mounting:** Maintenance-free ball bearings

Nominal data

Type	Motor	Curve	Nominal voltage range	Frequency	Speed ⁽¹⁾	Max. Input power ⁽¹⁾	Max. Input current ⁽¹⁾	Perm. ambient temp.	Weight	Techn. features and connection diagram
Type	Motor	VAC	Hz	rpm	kW	A	°C	kg		
R3G 280-AJ14 -C1	M3G 084-GF	Ⓐ	3~380-480	50/60	3260	0,99	1,60	-25..+60	6,8	P. 120 / RP5)
R3G 310-BC38 -01	M3G 112-GA	Ⓑ	3~380-480	50/60	3170	1,65	2,50	-25..+50	12,1	P. 116 / RP1)
R3G 355-BD43 -01	M3G 112-GA	Ⓒ	3~380-480	50/60	2650	1,73	2,60	-25..+60	12,6	P. 116 / RP1)
R3G 400-AS23 -01	M3G 150-FF	Ⓓ	3~380-480	50/60	2550	2,84	4,20	-25..+60	21,3	P. 116 / RP1)
R3G 450-AS24 -01	M3G 150-FF	Ⓔ	3~380-480	50/60	2040	2,38	3,60	-25..+60	22,0	P. 116 / RP1)

Subject to change

(1) Nominal data at operating point with maximum load and 400 VAC.

Curves:

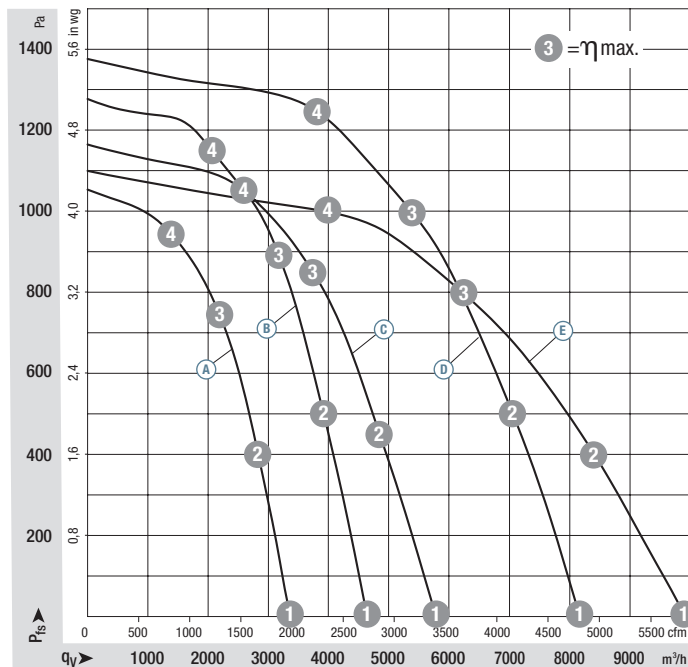

Air performance measured according to: ISO 5801, installation category A, with ebm-papst inlet ring without contact protection. Intake-side sound level: L_{WA} according to ISO 13347, L_{pA} measured at 1 m distance from fan axis. The values given are only applicable under the specified measuring conditions and may differ depending on the installation conditions. In the event of deviation from the standard configuration, the parameters must be checked in installed condition. See Page 126 ff. for detailed information.

	n rpm	P _{ed} kW	I A	L _{WA} dB(A)
Ⓐ ①	3260	0,70	1,31	89
Ⓐ ②	3260	0,88	1,57	86
Ⓐ ③	3260	0,99	1,60	84
Ⓐ ④	3260	0,87	1,57	85
Ⓑ ①	3170	1,23	1,83	90
Ⓑ ②	3170	1,52	2,27	88
Ⓑ ③	3170	1,65	2,50	85
Ⓑ ④	3170	1,54	2,30	88
Ⓒ ①	2650	1,25	1,86	90
Ⓒ ②	2650	1,56	2,33	86
Ⓒ ③	2650	1,73	2,60	84
Ⓒ ④	2650	1,63	2,42	86
Ⓓ ①	2550	2,10	3,13	92
Ⓓ ②	2550	2,59	3,84	89
Ⓓ ③	2550	2,84	4,20	86
Ⓓ ④	2550	2,68	3,95	89
Ⓔ ①	2040	1,64	2,48	90
Ⓔ ②	2040	2,16	3,23	85
Ⓔ ③	2040	2,38	3,60	82
Ⓔ ④	2040	2,17	3,24	86

- **Technical features:** See connection diagram P. 116 ff.
- **EMC:** ① Interference emission according to EN 61000-6-3, except EN 61000-3-2 for professionally used equipment with a total rated power greater than 1 kW
 - ② Immunity to interference according to EN 61000-6-2
- **Touch current:** <= 3,5 mA according to IEC 60990 (measuring circuit Fig. 4)
- **Terminal box design:** electrical connection via terminal strip
- **Protection class:** I (with customer connection of protective earth)
- **Conformity with standards:** EN 61800-5-1, CE
- **Approvals:** ④ C22.2 Nr.77 + CAN/CSA-E60730-1, EAC, UL 1004-7 + 60730
 - ⑤ ⑥ VDE, EAC
 - ⑦ ⑧ UL, CSA, EAC
- **Efficiency:** Ecodesign EU regulation EU 327/2011

EC centrifugal fans – RadiPac

backward curved, Ø 280 - 450 (Compact version)



R3G 280-AJ14-C1 (Centrifugal fan)

Accessory part: Inlet ring 28075-2-4013
Not included in scope of delivery (k-factor 93)

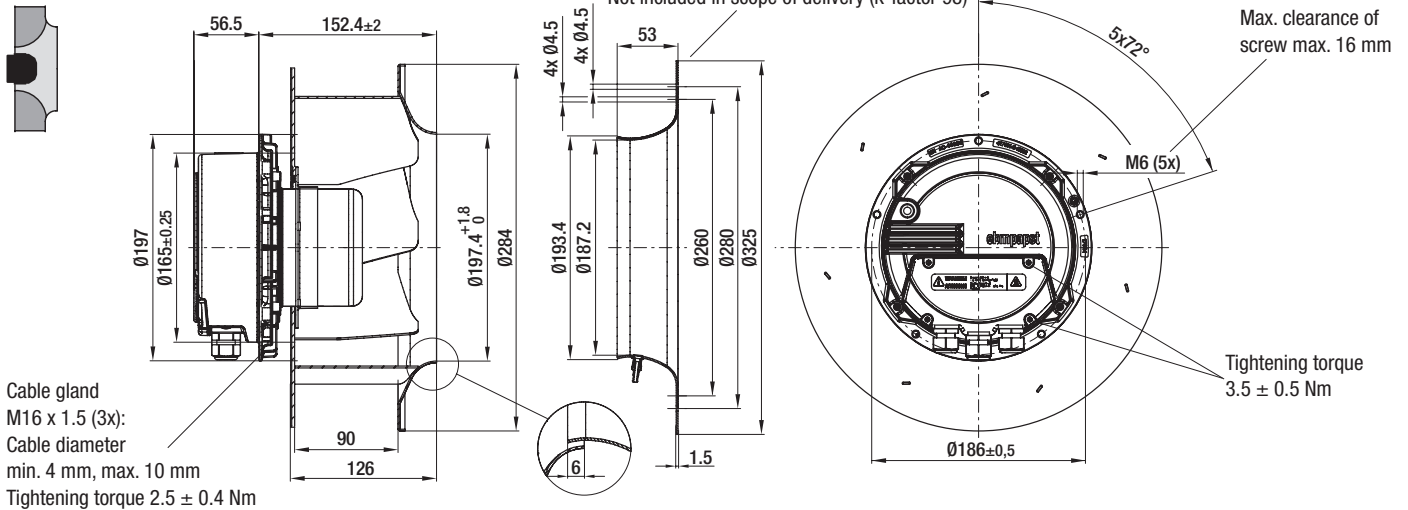

R3G 310-BC38-01 (Centrifugal fan)

Accessory part: Inlet ring 31475-2-4013
Not included in scope of delivery (k-factor 116)
Dimensions: see "Accessories" chapter

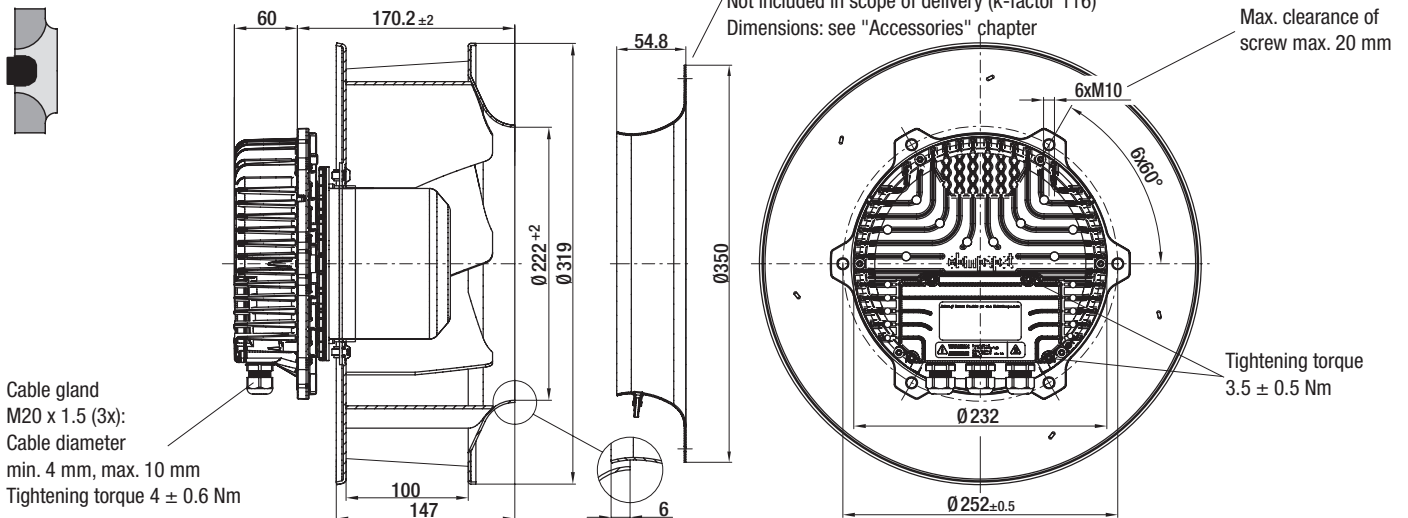

R3G 355-BD43-01 (Centrifugal fan)

Accessory part: Inlet ring 35675-2-4013
Not included in scope of delivery (k-factor 148)
Dimensions: see "Accessories" chapter

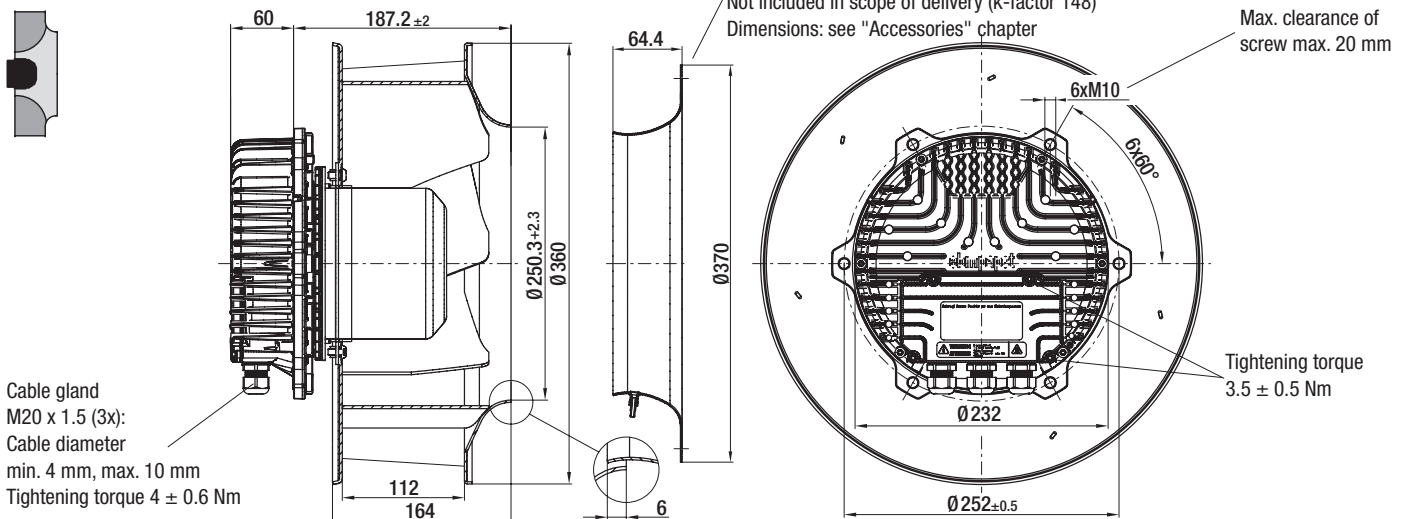

EC centrifugal fans – RadiPac

backward curved, Ø 280 - 450 (Compact version)



Information

Ø 250

Ø 280

Ø 310

Ø 355

Ø 400

Ø 450

Ø 500

Ø 560

Ø 630

Ø 710

Ø 800

Ø 1000

Short version

Compact version

ATEX version

Technology

Agents

R3G 400-AS23-01 (Centrifugal fan)

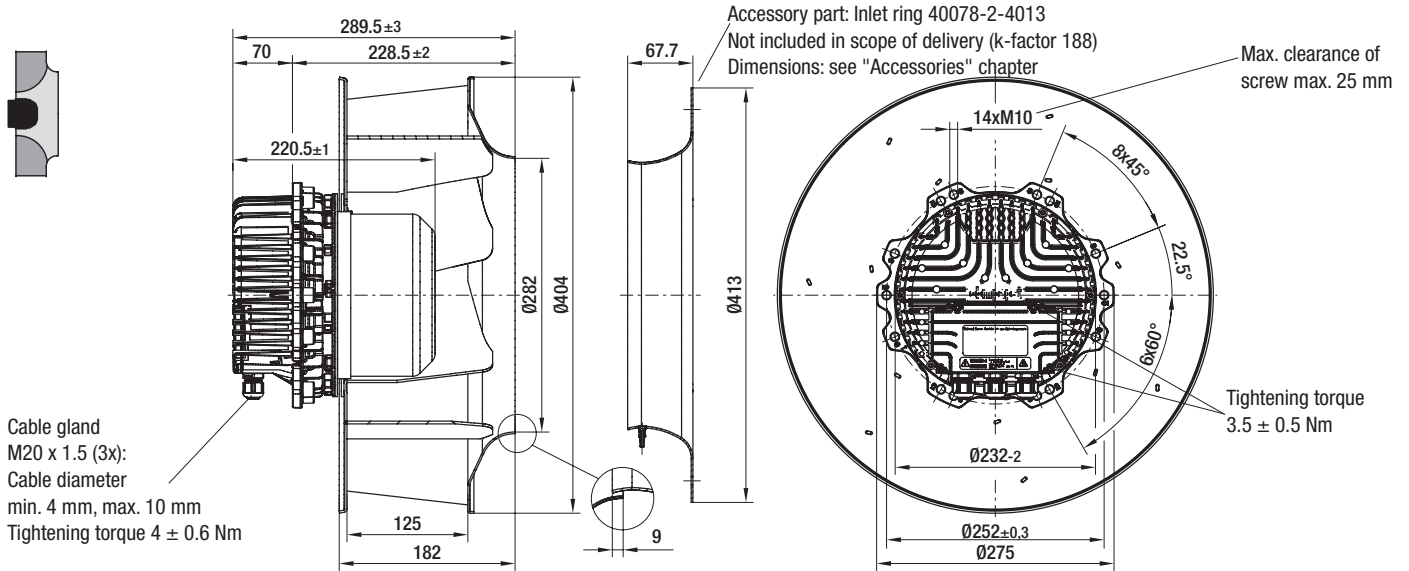

R3G 450-AS24-01 (Centrifugal fan)

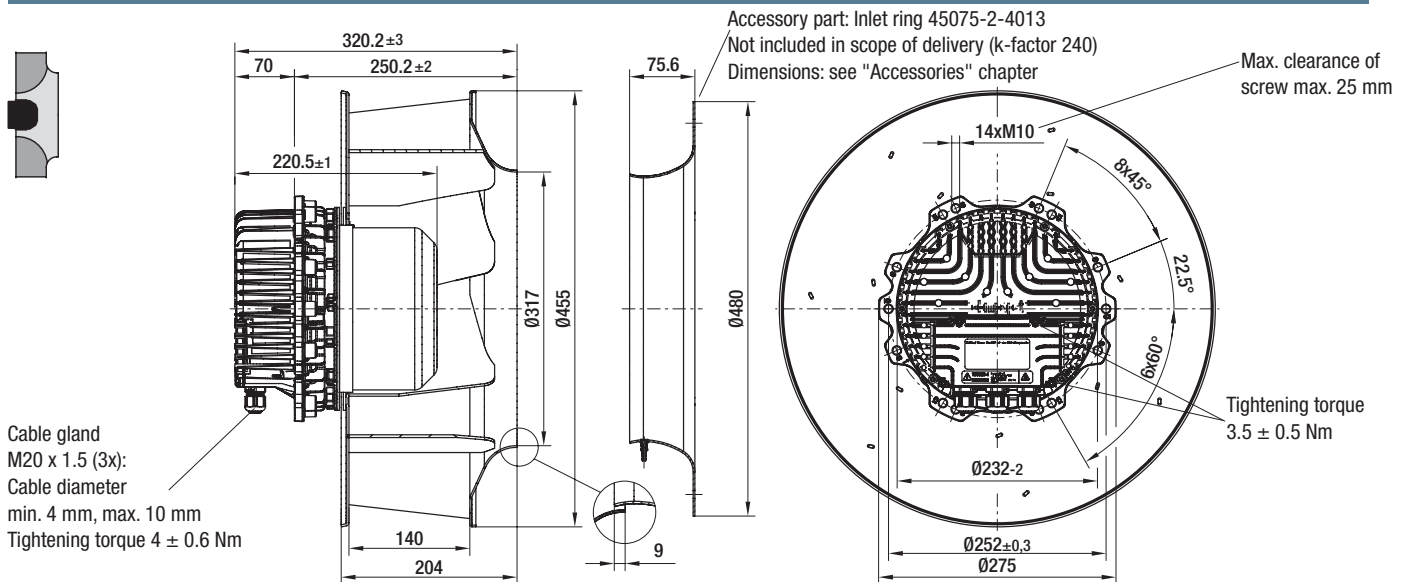

Atmosphere Explosive.

The European guideline on explosion protection.

Certified safety.

ebm-papst's ex-protected fans are based on the proven 3 kW GreenTech EC external rotor motor and are tested and certified in line with the European product directive 2014/34/EU. They therefore meet all demands made of devices used in areas at risk of explosion. Our axial and centrifugal ex-protected fans are suitable for equipment group II (explosion-protected areas outside mining) and the gases and vapours substance group in explosion group IIB.

Our ex-protected fans can be used in hazard zones 1 and 2. They therefore correspond to category 2G (ATEX) and have the equipment protection level Gb (EN 60079-0).

As per the ATEX 1999/92/EC operating directive, the facility operator is responsible for the categorisation of hazard zones. The corresponding equipment categorisation is performed by the manufacturer, i. e. ebm-papst.

ATEX fans:

RadiPac centrifugal fans for use in potentially explosive atmospheres.

These fans are available in sizes 400 to 630.

The combination of high-efficiency EC motor and integrated control electronics for use in potentially explosive atmospheres of Zones 1 and 2 is unique and simplifies the use of fans in such environments for the operator.



Ex marking of the ebm-papst fans as per ATEX and EN 60079-0:

Ex marking	Group	Equipment category	Ignition protection Types			Explosion group	Temperature classes	Equipment protection level	Escape of gases, fog and vapours (e.g. ammonia, methane, ethane, propane, town gas, acrylonitrile, hydrogen sulphide, ethyl ether, acet-aldehyde)
			Pressure-resistant enclosure Protection level	Increased safety Protection level	Intrinsic safety Protection level				
	3G	Corresponding to Zone 2		ic		IIA	T1 T2	Gc Increased protection	Zone 2 Hardly ever, rarely
	II 2G Ex		db	eb	ib	IIB	T3	Gb	Zone 1 Occasionally
		Required customer specification				Required customer specification			
Not available	I	1G Corresponding to Zone 0		ia		IIC	T4 T5 T6	Ga Very high protection	Zone 0 Constantly, often

The following requirements are not covered:

EC centrifugal fans – RadiPac

ATEX version, Ø 400 - Ø 630

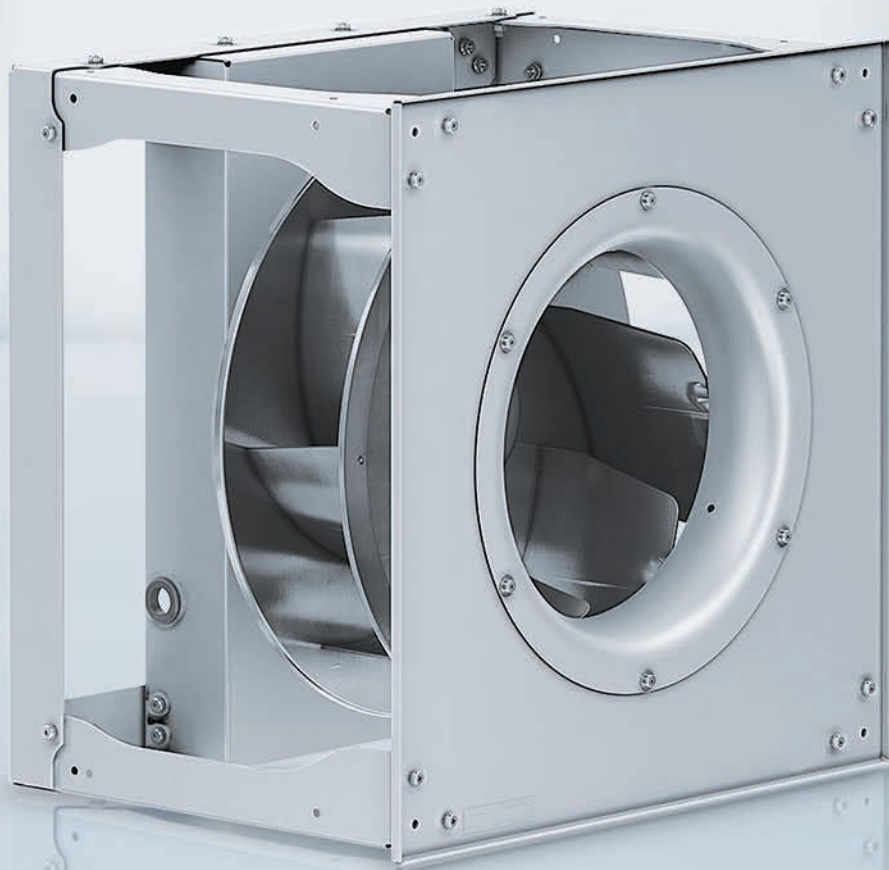



EC centrifugal fans – RadiPac

backward curved, Ø 400 - Ø 630 (ATEX version)

- **Material:** Cube design with inlet ring: Sheet steel, galvanized
Impeller: Sheet aluminium
Rotor: Painted black
Electronics housing: Die-cast aluminium
- **Number of blades:** 7
- **Direction of rotation:** Clockwise viewed toward rotor
- **Degree of protection:** IP 44
- **Insulation class:** "F"
- **Installation position:** Shaft horizontal (base mounting only) or rotor on bottom, rotor on top not allowed
- **Condensation drainage holes:** Rotor side
- **Mode:** Continuous operation (S1)
- **Mounting:** Maintenance-free ball bearings



Nominal data

Type	Motor	Curve	Nominal voltage range	Frequency	Speed ⁽¹⁾	Max. Input power ⁽¹⁾	Max. Input current ⁽¹⁾	Perm. ambient temp.	Weight	Techn. features and connection diagram
Type	Motor	VAC	Hz	rpm	kW	A	°C	kg		
*3G 400	M3G 150-FF	Ⓐ 3~380-480	50/60	2550	3,10	4,70	-25..+50	49,4	P. 122 / RP7)	
*3G 450	M3G 150-FF	Ⓑ 3~380-480	50/60	2040	2,95	4,50	-25..+50	57,5	P. 122 / RP7)	
*3G 500	M3G 150-FF	Ⓒ 3~380-480	50/60	1780	2,97	4,50	-25..+50	62,5	P. 122 / RP7)	
*3G 560	M3G 150-IF	Ⓓ 3~380-480	50/60	1500	2,94	4,50	-25..+50	80,8	P. 122 / RP7)	
*3G 630	M3G 150-NA	Ⓔ 3~380-480	50/60	1130	2,97	4,60	-25..+50	89,3	P. 122 / RP7)	

Subject to change



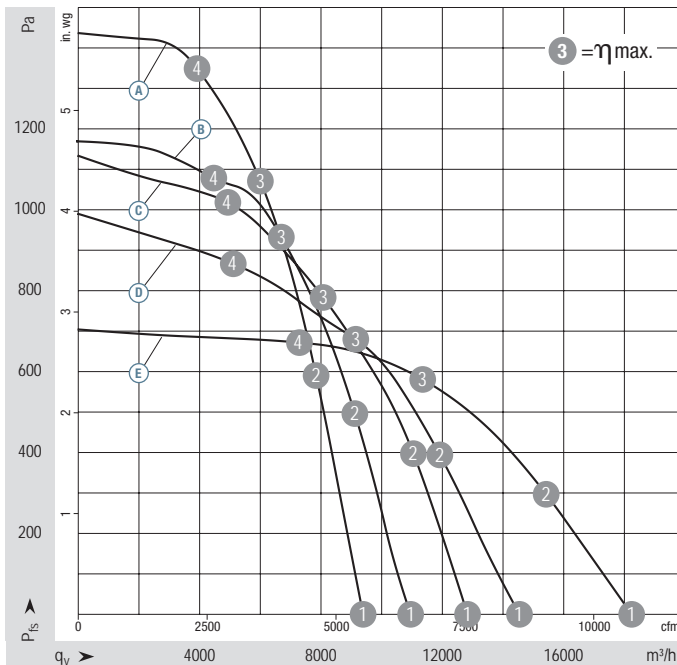

(1) Nominal data at operating point with maximum load and 400 VAC.

Curves:



Air performance measured according to: ISO 5801, installation category A, with ebm-papst inlet ring without contact protection. Intake-side sound level: L_{WA} according to ISO 13347, L_{pA} measured at 1 m distance from fan axis. The values given are only applicable under the specified measuring conditions and may differ depending on the installation conditions. In the event of deviation from the standard configuration, the parameters must be checked in installed condition. See Page 126 ff. for detailed information.

	n rpm	P _{ed} kW	I A	L _{WA} dB(A)
Ⓐ ①	2550	2,03	3,11	92
Ⓐ ②	2550	2,72	4,14	88
Ⓐ ③	2550	3,10	4,70	86
Ⓐ ④	2550	2,90	4,40	88
Ⓑ ①	2040	1,87	2,82	92
Ⓑ ②	2040	2,59	3,92	88
Ⓑ ③	2040	2,95	4,50	86
Ⓑ ④	2040	2,60	3,93	87
Ⓒ ①	1780	2,01	3,03	94
Ⓒ ②	1780	2,64	3,95	87
Ⓒ ③	1780	2,97	4,50	83
Ⓒ ④	1780	2,75	4,14	85
Ⓓ ①	1500	1,91	2,96	93
Ⓓ ②	1500	2,57	3,95	89
Ⓓ ③	1500	2,94	4,50	86
Ⓓ ④	1500	2,55	3,91	86
Ⓔ ①	1130	1,90	2,93	90
Ⓔ ②	1130	2,51	3,87	84
Ⓔ ③	1130	2,97	4,60	83
Ⓔ ④	1130	2,54	3,93	82

- **Technical features:** See connection diagram P. 122
- **EMC:**   Interference emission according to EN 61000-6-4 (industrial environment)
  Immunity to interference according to EN 61000-6-2 (industrial environment)
- **Touch current:** <= 3,5 mA
- **Terminal box design:** electrical connection via terminal strip
- **Protection class:** I (with customer connection of protective earth)
- **Conformity with standards:** EN 61800-5-1, CE, EN 14986, EN 60079-0, EN 60079-1, EN 60079-7, EN 60079-11
- **Approvals:** II 2G



Weight centrifugal module with cube design

Centrifugal module with cube design	kg
K3G 400-AQ23 -90	49,4
K3G 450-AQ24 -90	57,5
K3G 500-AP25 -90	62,5
K3G 560-AP23 -90	80,8
K3G 630-AP01 -90	89,3

Ø 250

Ø 280

Ø 310

Ø 355

Ø 400

Ø 450

Ø 500

Ø 560

Ø 630

Ø 710

Ø 800

Ø 1000

Short version

Compact version

ATEX version

Technology

Agents

EC centrifugal fans – RadiPac

backward curved, Ø 400 (ATEX version)



K3G 400-AQ23-90 (Centrifugal module with cube design)

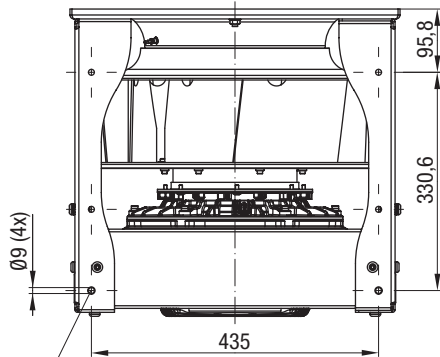

Mounting position for vibration-absorbing elements

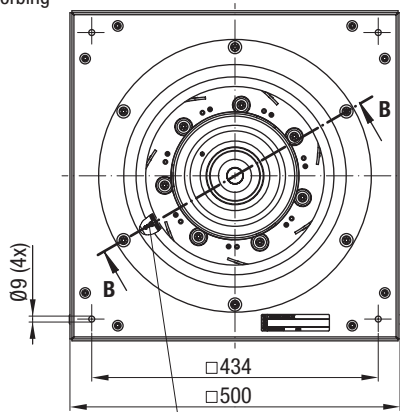

Inlet ring with pressure tap

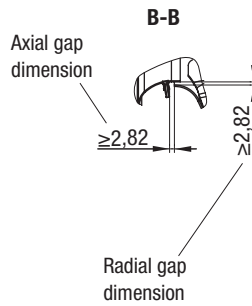

Terminal box cover fastening screws M4 x 20 (7x)
Tightening torque 3.5 ± 0.5 Nm

Screw plug M20 x 1.5

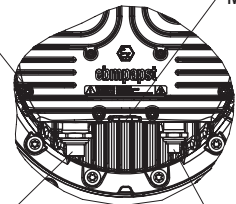

Cable gland M25 x 1.5: Cable diameter min. 10 mm, max. 16 mm
Tightening torque 6 ± 0.6 Nm
Approximate value depending on the cable

Cable gland M20 x 1.5: Cable diameter min. 10 mm, max. 14 mm
Tightening torque 6 ± 0.6 Nm
Approximate value depending on the cable

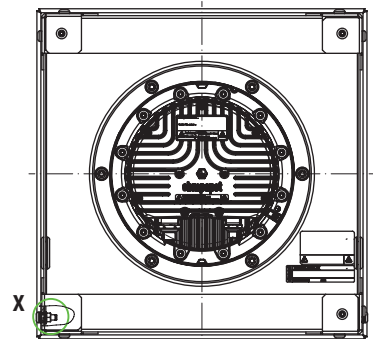
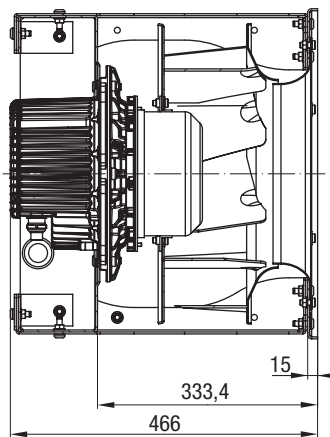

Ground connection point M8 (functional earthing for dissipation of electrostatic charge, no protective ground), do not unfasten the nut fitted, another nut is used for contacting.

Note installation position:

only designed for base mounting, shaft horizontal or rotor on bottom; rotor on top on request!

EC centrifugal fans – RadiPac

backward curved, Ø 450 (ATEX version)



K3G 450-AQ24-90 (Centrifugal module with cube design)

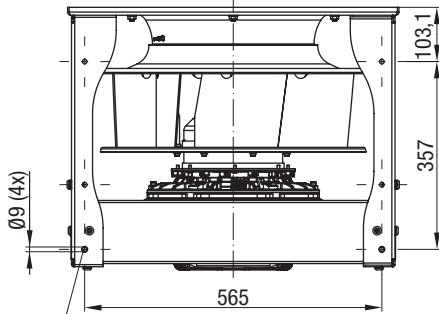

Mounting position for vibration-absorbing elements

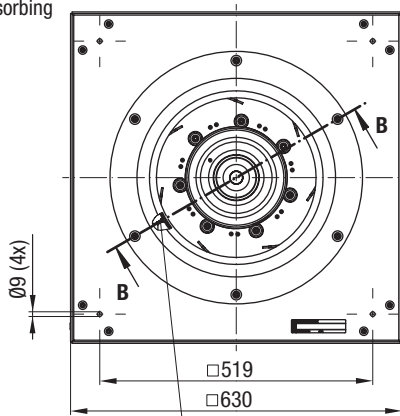

Inlet ring with pressure tap

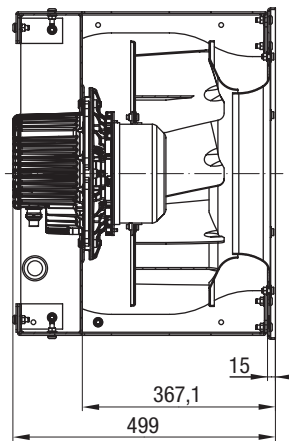
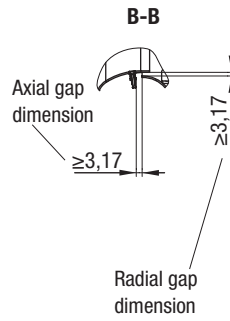

Terminal box cover fastening screws M4 x 20 (7x)
Tightening torque 3.5 ± 0.5 Nm

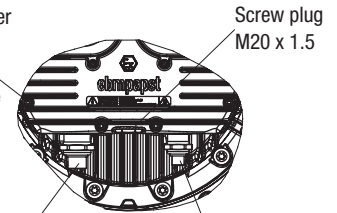

Screw plug M20 x 1.5

Cable gland M25 x 1.5: Cable diameter min. 10 mm, max. 16 mm
Tightening torque 6 ± 0.6 Nm
Approximate value depending on the cable

Cable gland M20 x 1.5: Cable diameter min. 10 mm, max. 14 mm
Tightening torque 6 ± 0.6 Nm
Approximate value depending on the cable

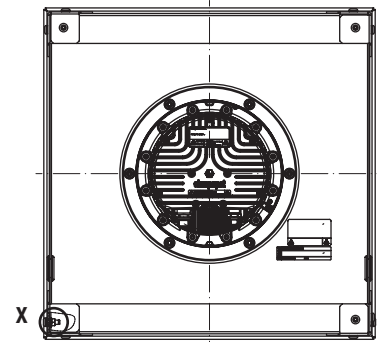

Ground connection point M8 (functional earthing for dissipation of electrostatic charge, no protective ground), do not unfasten the nut fitted, another nut is used for contacting.

Note installation position:

only designed for base mounting, shaft horizontal or rotor on bottom; rotor on top on request!

EC centrifugal fans – RadiPac

backward curved, Ø 500 (ATEX version)



K3G 500-AQ25-90 (Centrifugal module with cube design)

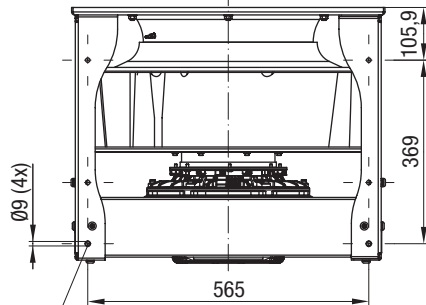

Mounting position for vibration-absorbing elements

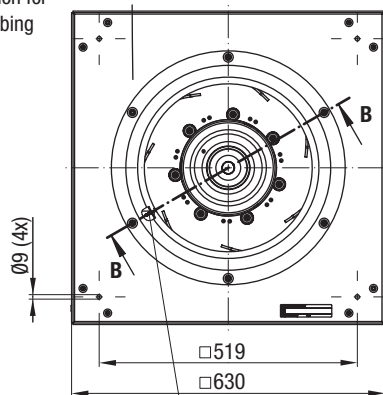

Inlet ring with pressure tap

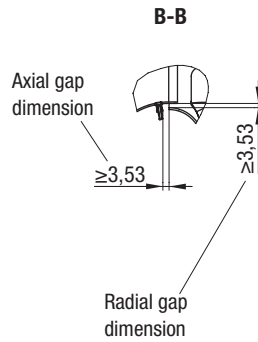

Axial gap dimension

Radial gap dimension

Terminal box cover fastening screws M4 x 20 (7x)
Tightening torque 3.5 ± 0.5 Nm

Screw plug M20 x 1.5

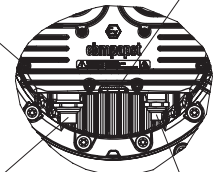

Cable gland M25 x 1.5: Cable diameter min. 10 mm, max. 16 mm
Tightening torque 6 ± 0.6 Nm
Approximate value depending on the cable

Cable gland M20 x 1.5: Cable diameter min. 10 mm, max. 14 mm
Tightening torque 6 ± 0.6 Nm
Approximate value depending on the cable

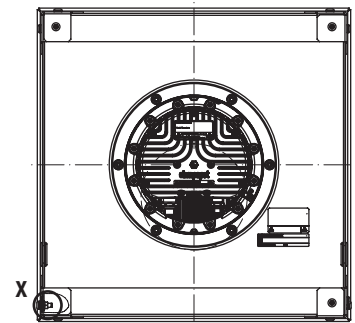
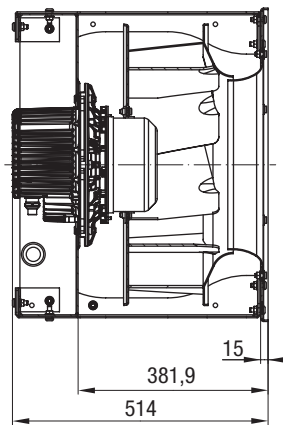

Ground connection point M8 (functional earthing for dissipation of electrostatic charge, no protective ground), do not unfasten the nut fitted, another nut is used for contacting.

Note installation position:

only designed for base mounting, shaft horizontal or rotor on bottom; rotor on top on request!

EC centrifugal fans – RadiPac

backward curved, Ø 560 (ATEX version)



K3G 560-AP23-90 (Centrifugal module with cube design)

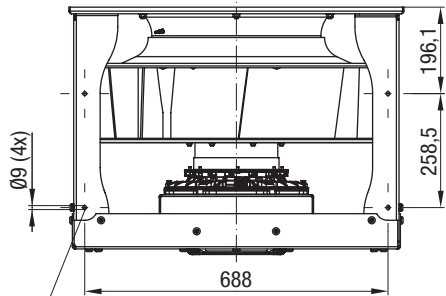

Mounting position for vibration-absorbing elements

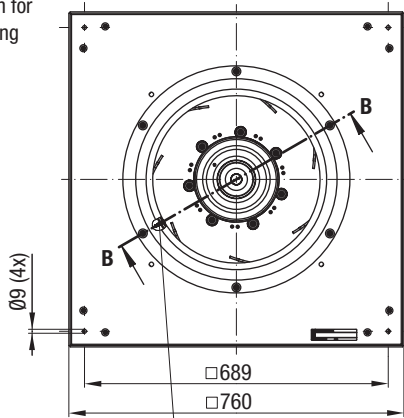

Inlet ring with pressure tap

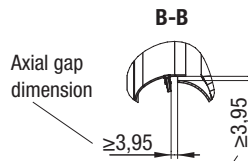

Axial gap dimension

Radial gap dimension

Terminal box cover fastening screws
M4 x 20 (7x)
Tightening torque
 3.5 ± 0.5 Nm

Screw plug
M20 x 1.5



Cable gland
M25 x 1.5: Cable diameter
min. 10 mm, max. 16 mm
Tightening torque 6 ± 0.6 Nm
Approximate value depending on the cable

Cable gland
M20 x 1.5: Cable diameter
min. 10 mm, max. 14 mm
Tightening torque 6 ± 0.6 Nm
Approximate value depending on the cable

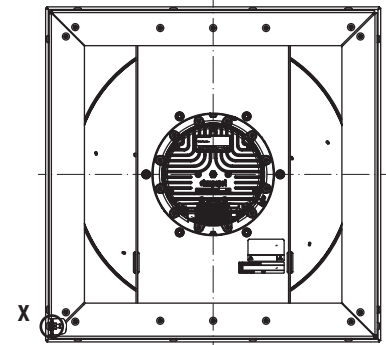
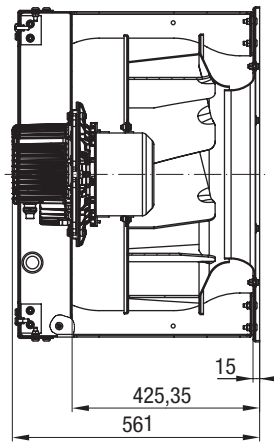

Ground connection point M8 (functional earthing for dissipation of electrostatic charge, no protective ground), do not unfasten the nut fitted, another nut is used for contacting.

Note installation position: shaft horizontal (motor support plate must stand upright) or rotor on bottom; rotor on top on request!

EC centrifugal fans – RadiPac

backward curved, Ø 630 (ATEX version)



K3G 630-AP01-90 (Centrifugal module with cube design)

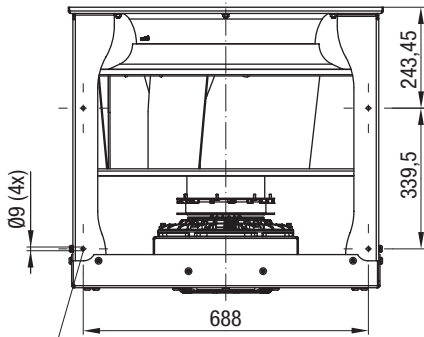

Mounting position for vibration-absorbing elements

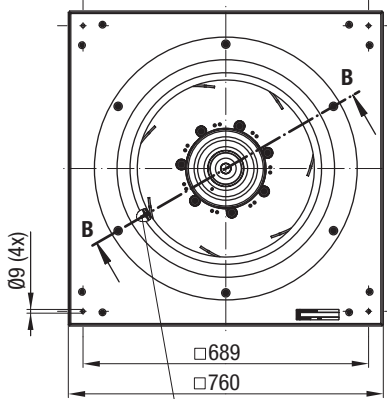

Inlet ring with pressure tap

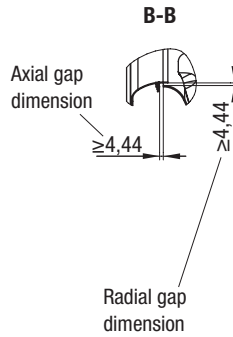

Axial gap dimension

Radial gap dimension

Terminal box cover fastening screws M4 x 20 (7x)
Tightening torque 3.5 ± 0.5 Nm

Screw plug M20 x 1.5



Cable gland M25 x 1.5: Cable diameter min. 10 mm, max. 16 mm
Tightening torque 6 ± 0.6 Nm
Approximate value depending on the cable

Cable gland M20 x 1.5: Cable diameter min. 10 mm, max. 14 mm
Tightening torque 6 ± 0.6 Nm
Approximate value depending on the cable

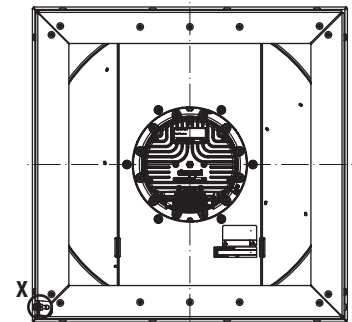
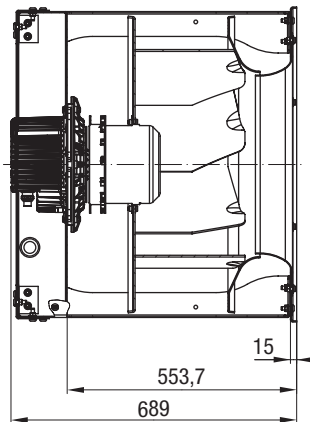

Ground connection point M8 (functional earthing for dissipation of electrostatic charge, no protective ground), do not unfasten the nut fitted, another nut is used for contacting.

Note installation position: shaft horizontal (motor support plate must stand upright) or rotor on bottom; rotor on top on request!

Agents	Technology	ATEX version	Compact version	Short version	Ø 1000	Ø 800	Ø 710	Ø 630	Ø 560	Ø 500	Ø 450	Ø 400	Ø 355	Ø 310	Ø 280	Ø 250	Information
--------	------------	--------------	-----------------	---------------	--------	-------	-------	-------	-------	-------	-------	-------	-------	-------	-------	-------	-------------

Tender specifications

Fan size 250 to 1000

Direct-drive single inlet centrifugal fans with backwards-curved high-performance centrifugal impellers with radial diffusers, mounted on a GreenTech EC external rotor motor with integrated control electronics.

Impeller made of aluminum, with 5 backwards-curved, continuously welded, hollow-profile blades; impeller sizes 250 and 280 made of plastic; flow-optimized inlet ring made of galvanized sheet steel with pressure test nipple.

Motor impeller statically and dynamically balanced on two planes to balancing grade G 6.3 (motor size 200 to balancing grade G 4.0) in accordance with DIN ISO 1940.

GreenTech EC external rotor motor surpasses efficiency class IE4, magnets with no rare earths, maintenance-free ball bearings with long-term lubrication, theoretical nominal service life of at least 40,000 hours of operation.

Soft start, integrated current limitation, extended voltage input 1~200-277 V, 50/60 respectively 3~380-480 V, 50/60 Hz. Fan can be used with all standard power supply networks with unaltered air performance. Integrated electronics, low-noise commutation logic; 100 % open-loop speed control; all fans have an RS485/MODBUS RTU interface, and do not need to be installed with shielded cables. All 1~ types have an integrated active PFC (Power Factor Correction) to reduce disturbing harmonic content. Terminal box made of aluminum/plastic with easily accessible connection area with spring-loaded terminals, environment-resistant cable glands, or with external variable cable (sizes 250 to 280).

Version for wall mounting:

Support bracket, sizes 250 to 560 and 630 to 800 with size 150 motor as ready-to-install support bracket intended for wall mounting. Support bracket made of bent round bar steel or round tube, welded and coated in black. Mounting plate and inlet ring made of sendzimir galvanized sheet steel.

Version for floor mounting:

Cube design, sizes 630 to 1000 with size 200 motor as ready-to-install cube design intended exclusively for floor mounting. Struts made of extruded aluminum sections connected to die-cast corner plates, nozzle plate and inlet ring made of sendzimir galvanized sheet steel, motor mounting plate made of coated sheet steel. This version is not suitable for wall mounting.

Any work required for isolation from structure-borne noise to be performed by the customer. Fan satisfies the applicable EMC guidelines and requirements with regard to circuit feedback (for specific information, see the respective data sheet). Documentation and marking conform to the applicable EU Directives.

Reliable performance data, air performance measurements on intake-side chamber test rig according to ISO 5801 and DIN 24163, noise measurements in anechoic rooms according to DIN EN ISO 3745.

Integrated protective devices:

- Alarm relay with zero-potential change-over contacts (250 V AC/2 A, $\cos \varphi = 1$)
- Locked-rotor protection
- Phase failure detection
- Soft start of motors
- Mains under-voltage detection
- Thermal overload protection for electronics and motor
- Short circuit protection

Optional:

- Other and specific requirements on request

Technical data:

Fan type		= _____ - _____ - _____
Air flow	qV	= _____ m ³ /h, cfm
Stat. pressure increase	pfs	= _____ Pa, in wg
Stat. overall efficiency	η_{es}	= _____ %
Operating speed	n	= _____ rpm
Motor type		= EC motor
Type of control		= 0-100 % speed control
Motor efficiency class		= IE4 equivalent or better
Total power input	Ped	= _____ kW
Specific fan power	SFP	= _____ kW/(m ³ /s)
Nominal voltage range	U _N	= _____ V
Line frequency	f	= 50 / 60 Hz
Nominal current	I _N	= _____ A
Degree of protection		= IP54
Sound power level	L _{WA} (A, in)	= _____ / L _{WA} (A, out) = _____ dB(A)
Sound pressure level (at 1 m)	L _{pA} (A, in)	= _____ / L _{pA} (A, out) = _____ dB(A)
Perm. ambient temperature	T	= _____ to _____ °C
Weight of fan	m	= _____ kg



EC centrifugal fans - RadiPac
Support bracket
Sizes 250 - 800



EC centrifugal fans - RadiPac
Cube design
Sizes 630 - 1000

Refer to data sheet for dimensions and wiring.



Accessories

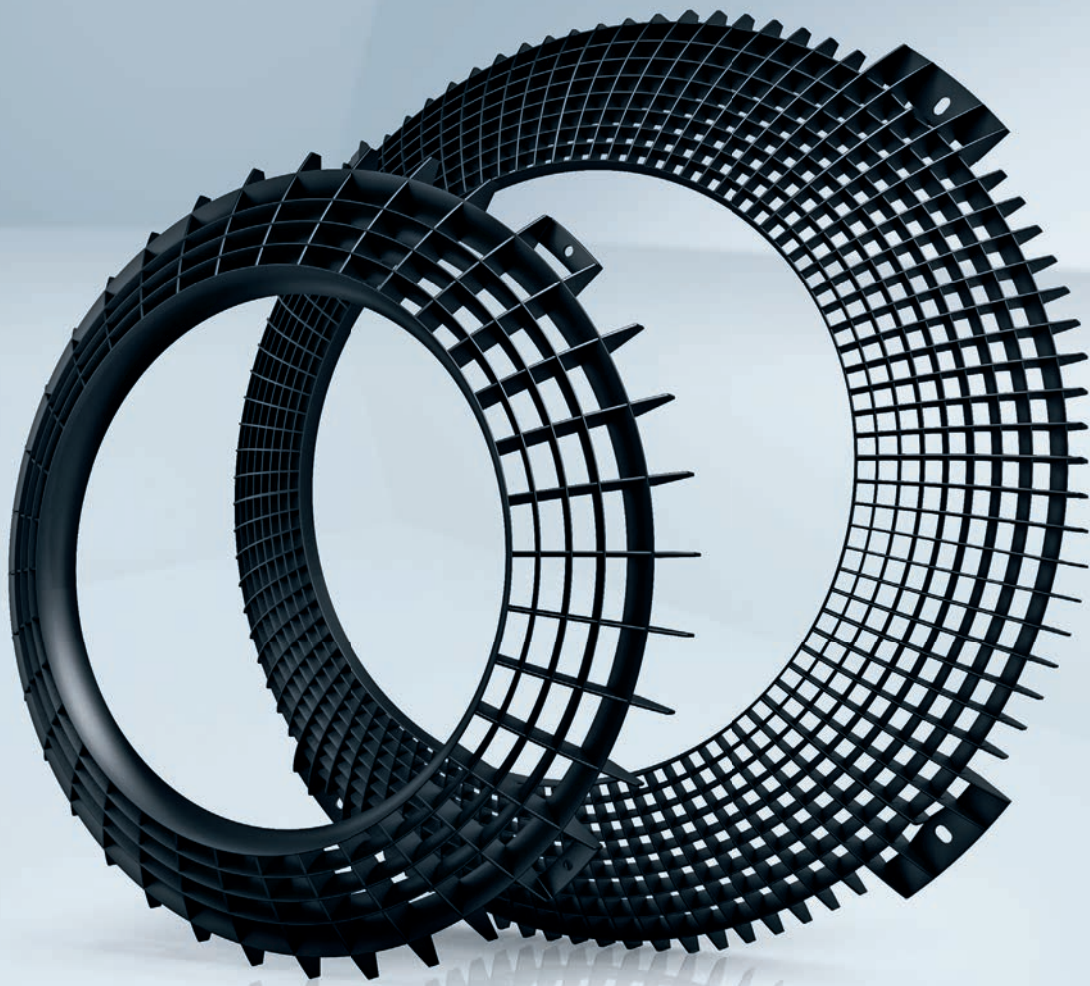

Information

Ø 250

Ø 280

Ø 310

Ø 355

Ø 400

Ø 450

Ø 500

Ø 560

Ø 630

Ø 710

Ø 800

Ø 1000

Short version

Compact version

ATEX version

Technology

Agents

FlowGrid air inlet grill

Efficient noise reduction

ebm-papst fans are not measured on our own advanced test stands just for their air performance alone. The acoustic behavior of the fans is also examined and the measurement results are included in the technical documentation.

Please note that the measurements are taken under ideal conditions with undisturbed inflow and outflow. If the fans are subsequently installed and used in devices with rather tight spaces, it is to be expected that the noise data provided in the documentation will not be applicable.

In order to minimize the negative impact of the installation situation, ebm-papst offers the FlowGrid air-inlet guard shown here. It is installed on the intake side of the fan and effectively reduces the noise generated by the fan. Particularly annoying, low-frequency noises are reduced efficiently. The level of noise reduction is dependent on the installation situation, which is why no generally applicable data is possible here.



FlowGrid air inlet grill

Dimensions (mm)

Part number	Fan size	ØB	ØC	ØE	S	H	N*
20280-2-2957	250, 280	280	245-261	4,5	3,5	40	2 ± 0,5 Nm
25310-2-2957	310	315	288-292	5,5	3,5	49	2 ± 0,5 Nm
00400-2-2957	355	370	334-346	4,5	3,5	56	2 ± 0,5 Nm
35505-2-2957	400, 450, 500	470	440	9,0	3,5	71	10 ± 2 Nm
00630-2-2957	560, 630	580	545	10	3,0	90	10 ± 2 Nm
50710-2-2957	710	666	630	10	3,0	106	10 ± 2 Nm
63000-2-2957	800	785	750	10	3,0	125	10 ± 2 Nm

Subject to change

* Recommended tightening torque for fastening screws

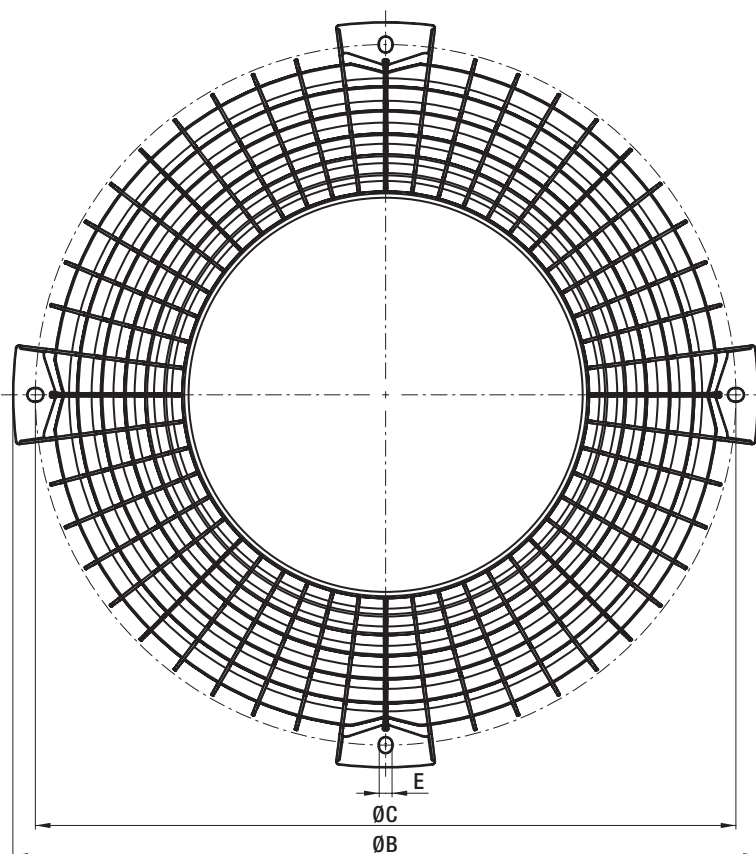

Would you like to find out more?

If you need an installation guide or more information about the dimensions, go to:

www.ebmpapst.com/flowgrid-manual

or scan the QR code below:



Intake finger guard

Wire mesh finger guard

- **Material:** Steel wire, phosphated,
 Versions 1 and 2: Painted pebble gray (RAL 7032)
 Versions 3 and 4: Painted light gray (RAL 7035)

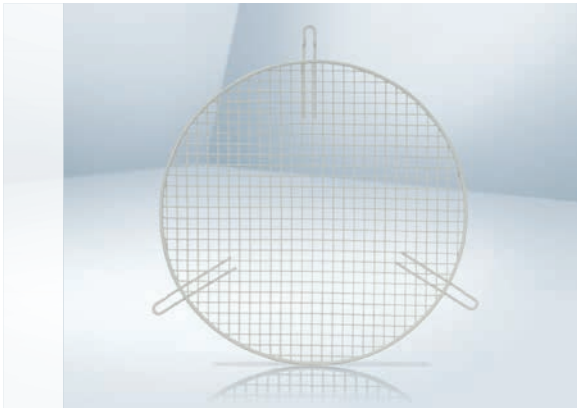

Intake finger guard for backwards-curved centrifugal fans (according to EN ISO 13857)

Part number	Fan size	Version	a	b	d	e	Strut division	Dimensions (mm)
79280-2-4039	250, 280	1	280	4,5	227	2,8	4 x 90°	Ø 250
79310-2-4039	310	1	325	4,5	271	2,8	4 x 90°	Ø 280
79355-2-4039	355	1	345	4,5	308	2,8	4 x 90°	Ø 310
79400-2-4039	400	2	390	8,5	343	2,8	3 x 120°	Ø 355
79500-2-4039	450, 500	2	445	8,5	417	2,8	3 x 120°	Ø 400
79560-2-4039	560	2	490	8,5	466	2,8	3 x 120°	Ø 450
79630-2-4039	630	3	600	8,5	551	3,9	3 x 120°	Ø 500
79710-2-4039	710, 800	3	700	8,5	651	3,9	3 x 120°	Ø 560
79900-2-4039	1000	4	850	8,5	801	3,9	6 x 60°	Ø 630

Subject to change

Version 1

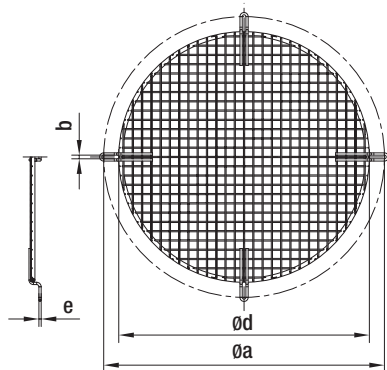

Version 2

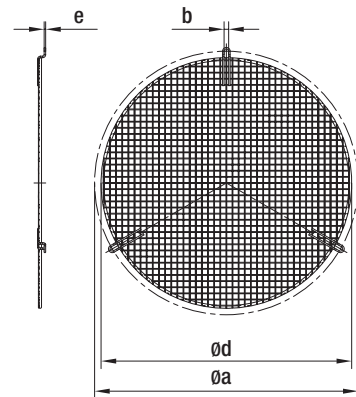

Version 3

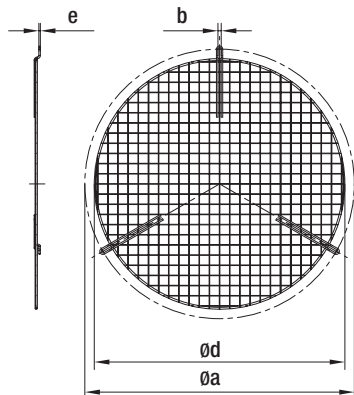

Version 4

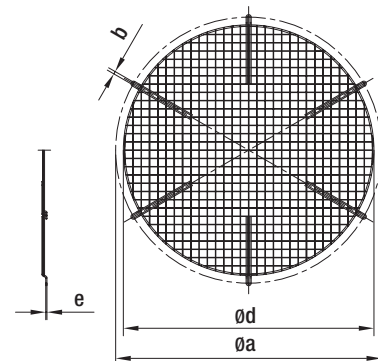

Inlet rings

With / without measuring device

– **Material:** Galvanized sheet steel



Inlet rings with / without measuring device to determine the air flow for backwards-curved centrifugal fans

Part number	Fan size	Dimensions / drawing
96350-2-4013 ⁽¹⁾ / 96355-2-4013 ⁽²⁾ / 96345-2-4013 ⁽³⁾	250	siehe Seite 107
28000-2-4013 ⁽¹⁾ / 28004-2-4013 ⁽²⁾ / 28003-2-4013 ⁽³⁾	280	siehe Seite 107
28070-2-4013 ⁽¹⁾ / 28075-2-4013 ⁽²⁾ / 28080-2-4013 ⁽³⁾	280 (compact)	siehe Seite 88-89
31470-2-4013 ⁽¹⁾ / 31475-2-4013 ⁽²⁾ / 31480-2-4013 ⁽³⁾	310	siehe Seite 107
35670-2-4013 ⁽¹⁾ / 35675-2-4013 ⁽²⁾ / 35680-2-4013 ⁽³⁾	355	siehe Seite 107
40073-2-4013 ⁽¹⁾ / 40078-2-4013 ⁽²⁾ / 40083-2-4013 ⁽³⁾	400	siehe Seite 107
45070-2-4013 ⁽¹⁾ / 45075-2-4013 ⁽²⁾ / 45080-2-4013 ⁽³⁾	450	siehe Seite 107
63072-2-4013 ⁽¹⁾ / 64025-2-4013 ⁽²⁾ / 64002-2-4013 ⁽³⁾	500	siehe Seite 108
63071-2-4013 ⁽¹⁾ / 64030-2-4013 ⁽²⁾ / 64001-2-4013 ⁽³⁾	560	siehe Seite 108
63070-2-4013 ⁽¹⁾ / 64040-2-4013 ⁽²⁾ / 64000-2-4013 ⁽³⁾	630	siehe Seite 109
71070-2-4013 ⁽¹⁾ / 71075-2-4013 ⁽²⁾ / 71080-2-4013 ⁽³⁾	710	siehe Seite 109
80070-2-4013 ⁽¹⁾ / 80075-2-4013 ⁽²⁾ / 80080-2-4013 ⁽³⁾	800	siehe Seite 109

Subject to change

⁽¹⁾ Without measuring device

⁽²⁾ With one pressure tap

⁽³⁾ With piezometer

(1) Without measuring device:

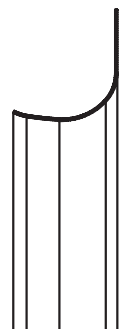

(2) With one pressure tap:

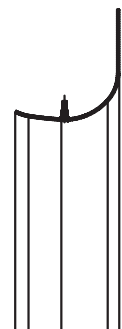

(3) With piezometer:

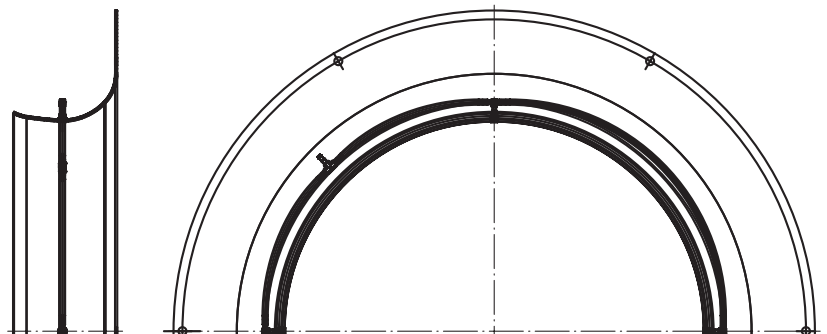

Inlet rings

Dimensioned drawings with one pressure tap

Fan size 250:

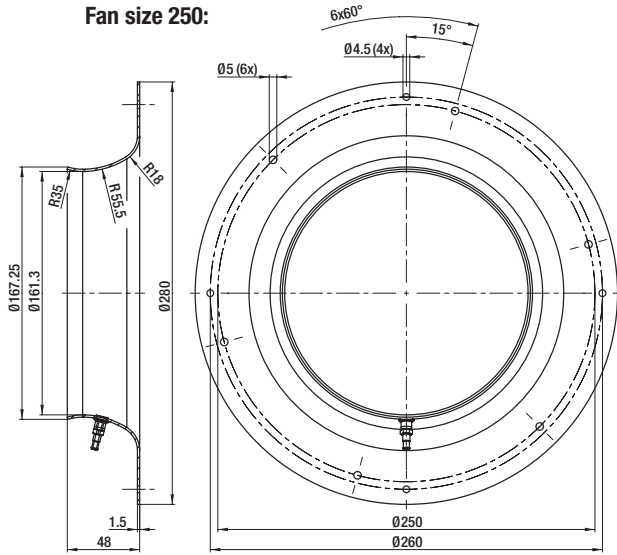

Fan size 280:

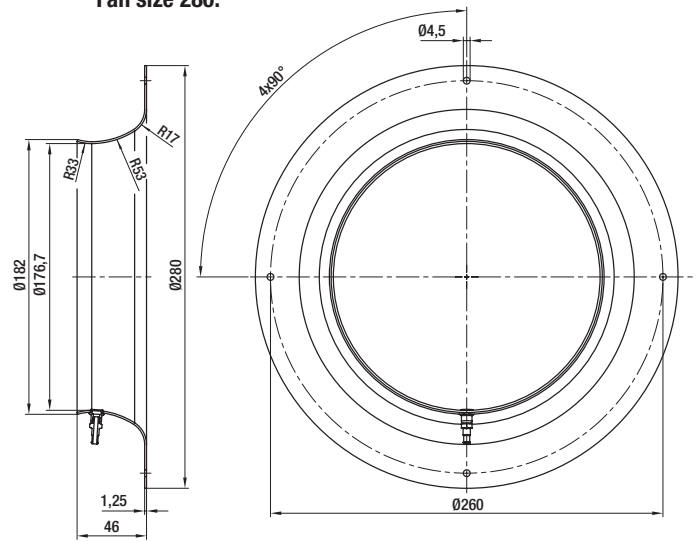

Fan size 310:

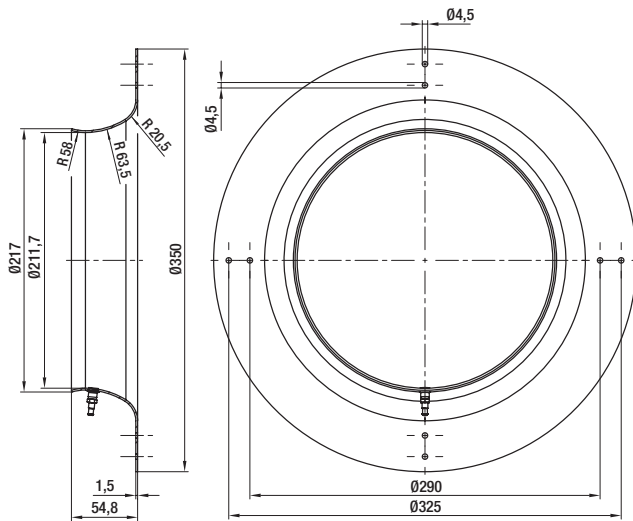

Fan size 355:

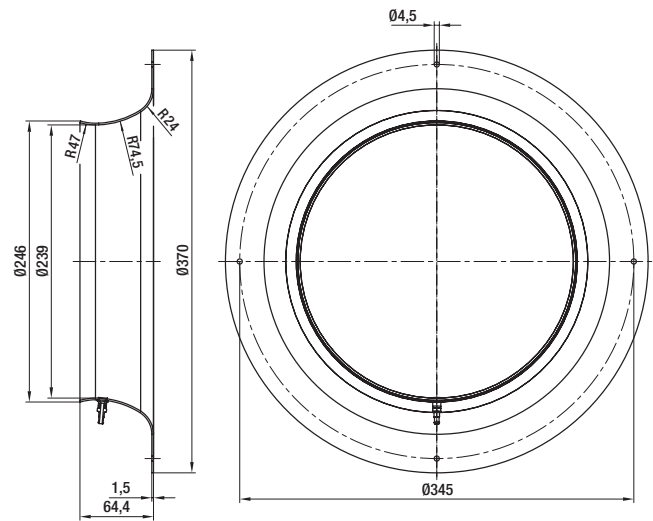

Fan size 400:

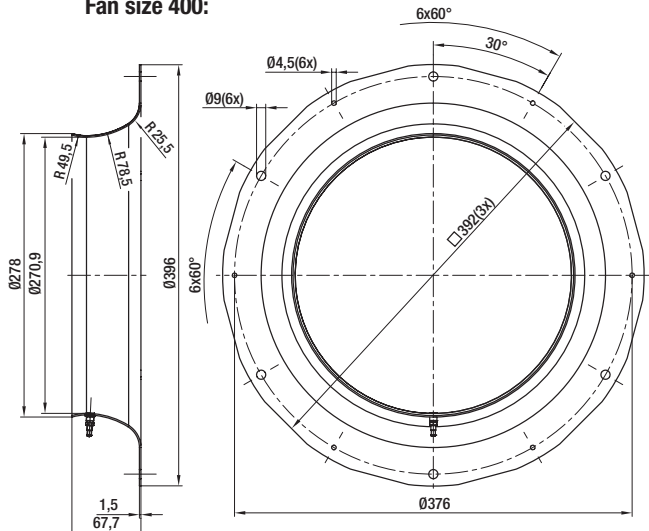

Fan size 450:

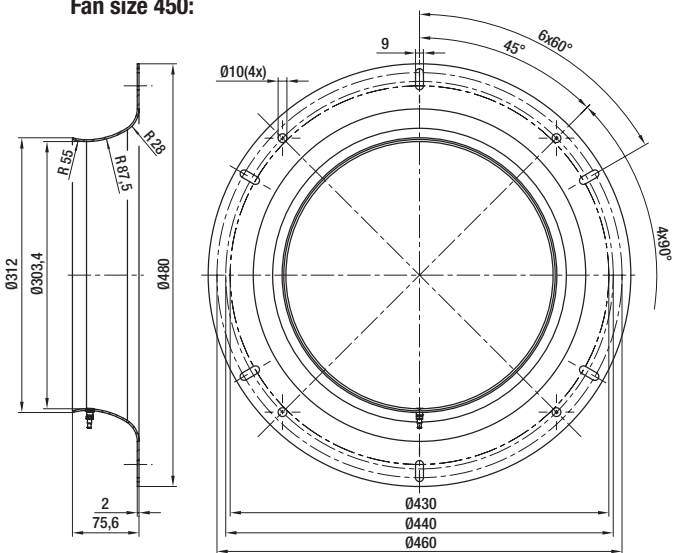

Inlet rings

Dimensioned drawings with one pressure tap

Fan size 500:

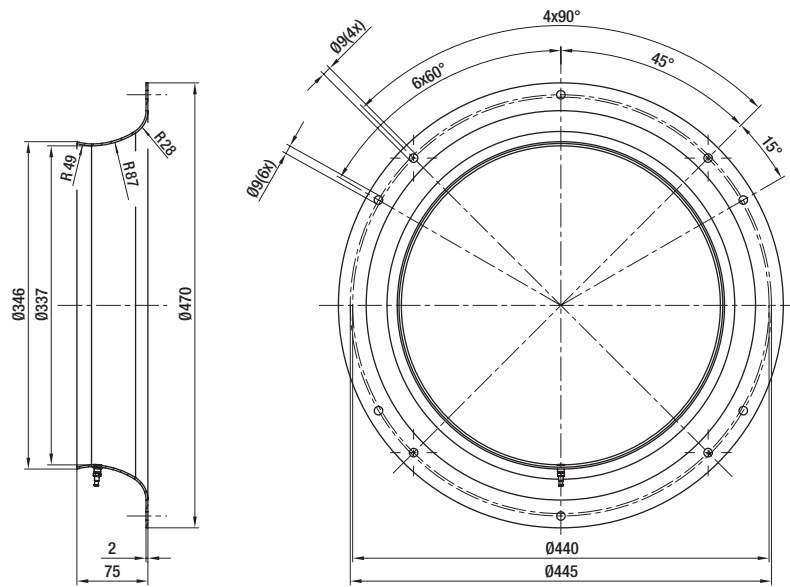

Fan size 560:

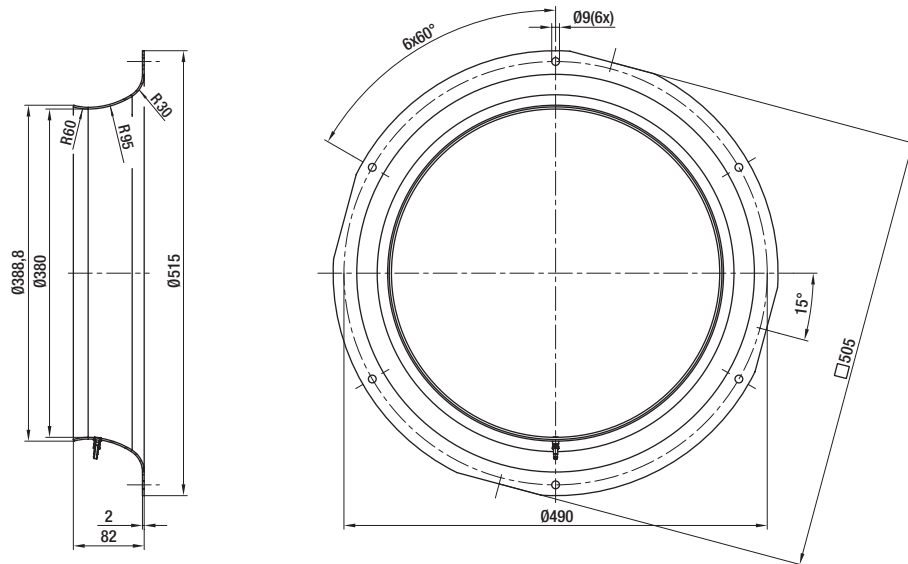

Inlet rings

Dimensioned drawings with one pressure tap

Fan size 630:

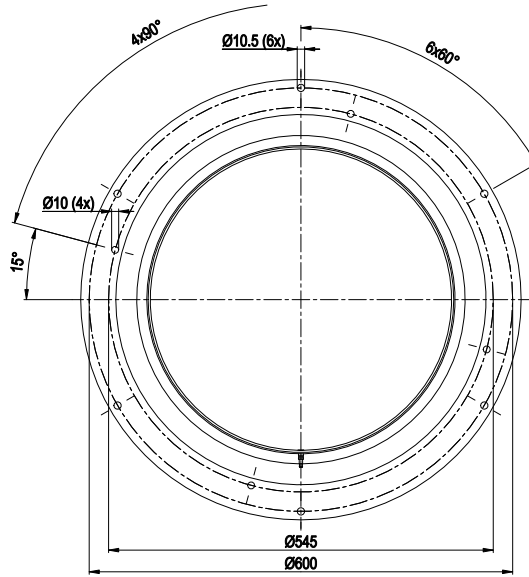
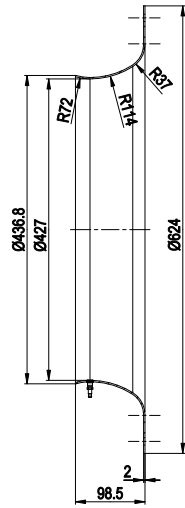

Fan size 710:

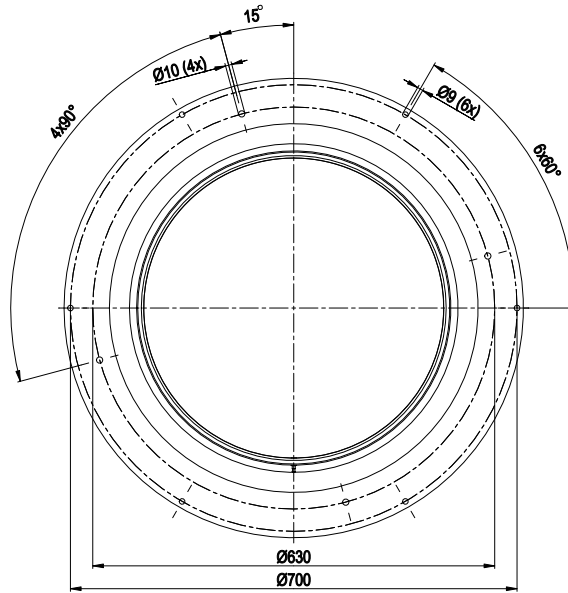
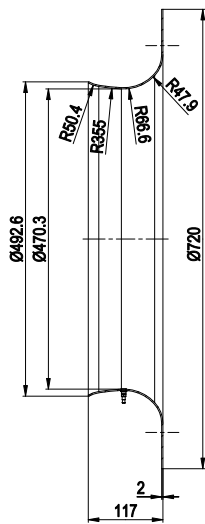

Fan size 800:

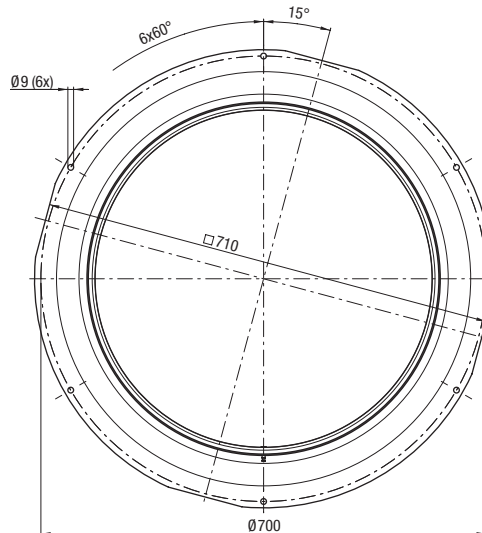
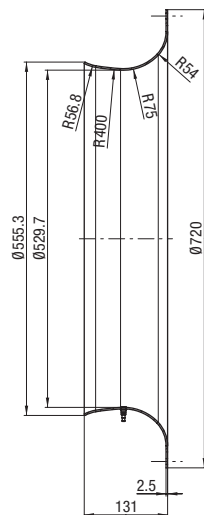

Effects of installation space

Effects of installation space:

Installation in a square box may cause a reduction of the air performance.

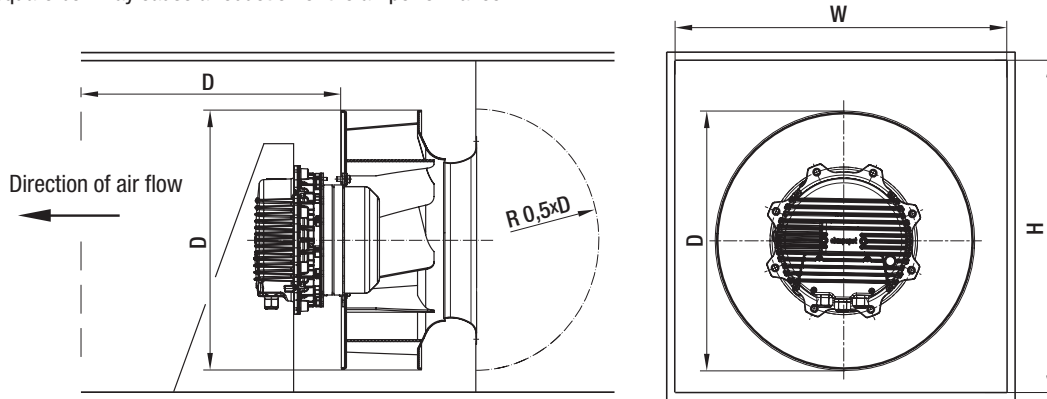

- d_h = Hydraulic diameter
 Formula: $d_h = 2 \times W \times H / (W + H)$
 W = Width of the box
 H = Height of the box
 D = Outside diameter of the fan

Correction values for the air flow Fan size 250 - 1000:

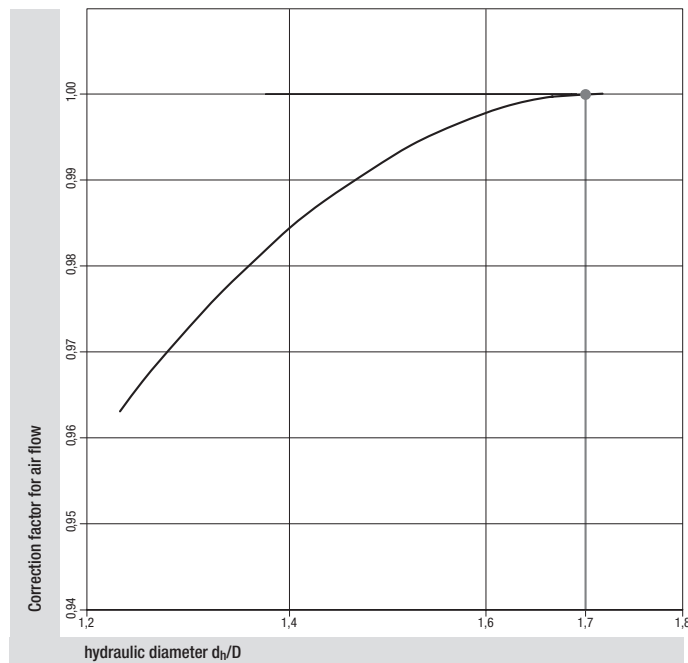

The correction values shown here were determined from an extensive series of measurements taken on our own internal chamber test rig.

Here, square and rectangular outflow cross sections were considered.

This is why the hydraulic diameter was used to determine the correction values.

The new RadiPac fans are known to be less vulnerable to tight installation situations.

For square cross sections that are greater than 1.7 x the impeller diameter, no deduction has to be applied to the catalog curves.

Air flow measurement

Air flow measurement:

The differential pressure method compares the static pressure upstream of the inlet ring with the static pressure in the inlet ring.

The air flow can be calculated from the differential pressure (between the static pressures) according to the following equation:

$$q_V = k \cdot \sqrt{\Delta p} \quad q_V \text{ in [m}^3/\text{h]} \text{ and } \Delta p \text{ in [Pa]}$$

If the air flow is to be regulated to remain constant, the inlet pressure must be kept constant:

$$\Delta p = q_V^2 : k^2$$

k takes into account the specific properties of the inlet ring.

The pressure is tapped at 1 (4) point(s) on the circumference of the inlet ring. The customer connection consists of a built-in T-shaped hose fitting. The hose fitting is suitable for pneumatic hoses with an inside diameter of 4 mm.

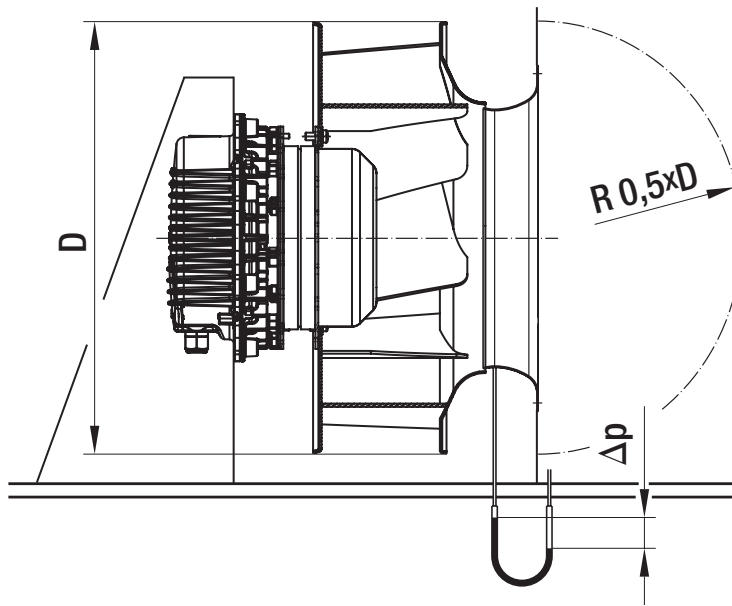

k-factors: (for RadiPac inlet rings)

Fan size	250	280	310	355	400	450	500
k-factor	76	77	116	148	188	240	281
Fan size	560	630	710	800	1000		
k-factor	348	438	545	695	1200		

Vibration absorbers

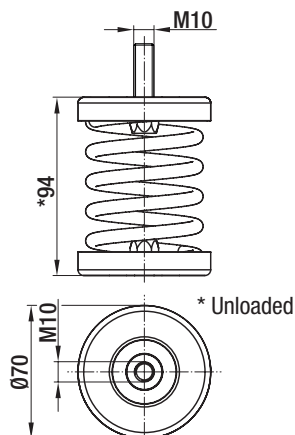

- **Packaging:** Part numbers refer to one set consisting of 4x spring elements each.

Supplied in a box.

- **For further information, see:**
Installation instructions no.: 45014-4-8670

Vibration absorbers (steel)

Part number (set)	Type	Minimum speed (rpm)	Deflection (mm)
11064-4-5142	K3G 630-PV04-01	510	7,5
11065-4-5142	K3G 630-PW04-01	570	5,9
11065-4-5142	K3G 710-PV05-01	530	6,5
11065-4-5142	K3G 710-PW06-01	490	7,8
11065-4-5142	K3G 800-PV13-01	500	7,4
11065-4-5142	K3G 800-PW07-01	480	8,0
11064-4-5142	K3G A00-PV03-01	370	13,8

Subject to change

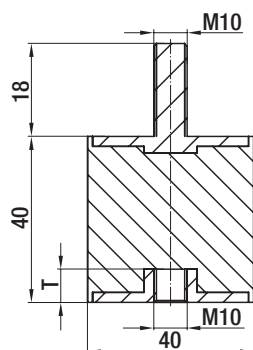

- **Packaging:** Part numbers refer to one set consisting of 4x rubber buffers, washers, and nuts each.

Supplied in a box.

- **For further information, see:**
Installation instructions no.: 45014-4-8670

Vibration absorbers (rubber)

Part number (set)	Type	Minimum speed (rpm)	Deflection (mm)
10005-4-5164	K3G 630-PV04-01	790	2,1
10005-4-5164	K3G 630-PW04-01	725	2,5
10005-4-5164	K3G 710-PV05-01	701	2,6
10005-4-5164	K3G 710-PW06-01	629	3,3
10005-4-5164	K3G 800-PV13-01	656	3,1
10005-4-5164	K3G 800-PW07-01	620	3,4
10008-4-5164	K3G A00-PV03-01	496	5,3

Subject to change

Attention:

The vibration absorbers recommended by ebm-papst are available in a set of 4 pieces. The vibration absorbers are perfectly matched to their intended fans and the specified minimum speed. The installation and operation of several fans on one set of spring elements is not allowed. During start-up, the fan has to pass through the speed range corresponding to the resonance frequency (below the minimum speed). The vibrations caused by the fan's residual imbalance are strongest within this speed range. This speed range must be passed through as quickly as possible to avoid damage to the fan. Operation below, close to or at the resonance frequency will destroy the fan!

When the fan is being operated, take care to ensure that the fan's speed does not go below the specified minimum speed. This will prevent the fan from being operated continuously near the resonance frequency. The specified minimum speed is always for an individual fan without any influences from the system it is installed in.

The configuration of the unit in which the fan is installed can have a strong influence on the fan's vibration characteristics, so a vibration test always has to be performed after the fan has been installed. The fan's vibration characteristics must be tested under all relevant operating conditions (such as speed, back pressure, systemic fluctuations in back pressure) – when installed and in interaction with the complete system.

The maximum vibration severity may not exceed 3.5 mm/s, measured at the motor's fastening pitch circle on the motor support plate in the direction of and perpendicular to the motor's axis of rotation.

Even when the vibration absorbers recommended by ebm-papst are used, their effectiveness must be tested in the application. If vibration absorbers other than those specified are used, tests must be performed to determine how the resonance frequency, and thus the operating requirements, change.

Installation example: Floor-mounted, shaft horizontal

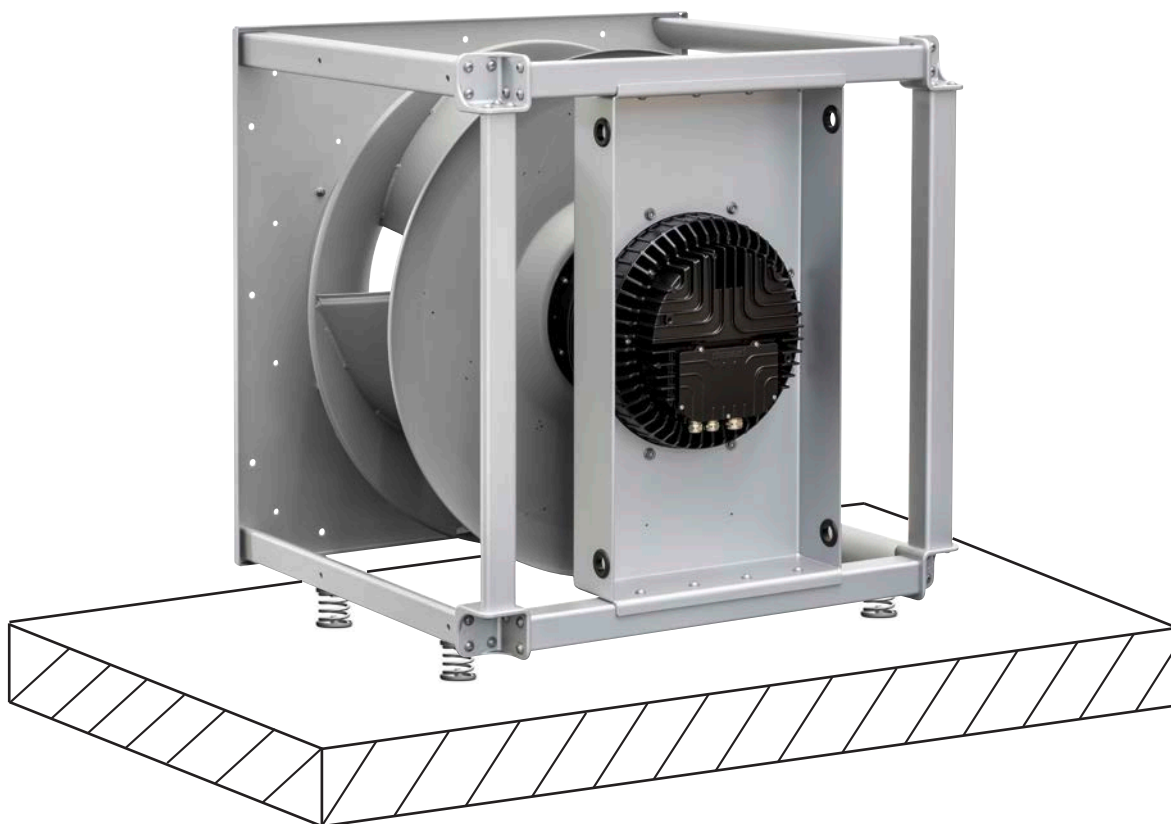



Connection diagrams

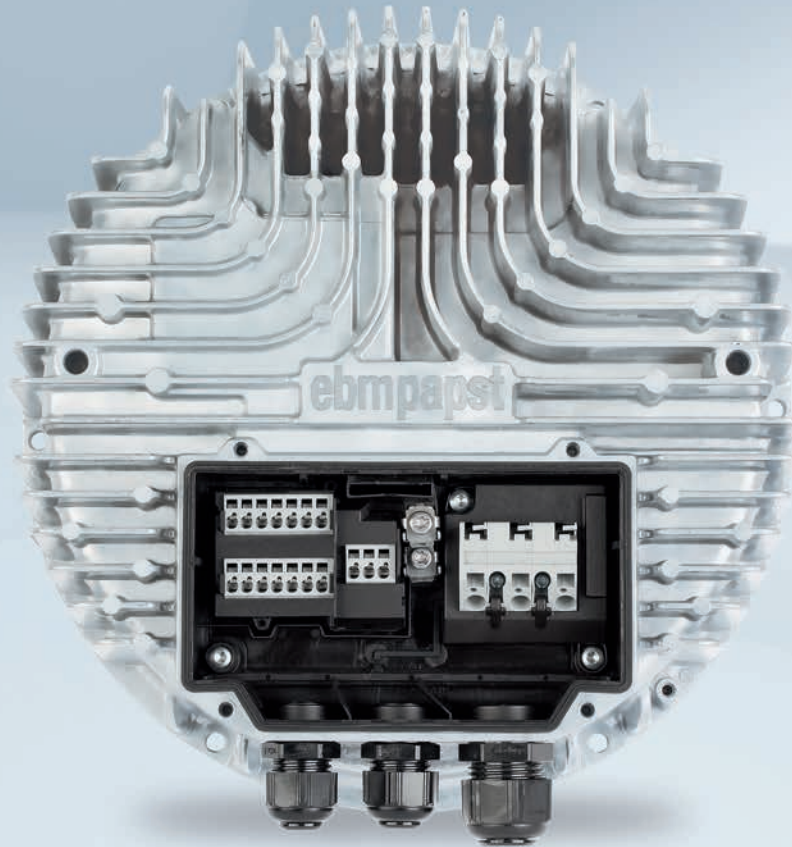

Connection diagram: RP1)

M3G112 & M3G150 & M3G200, 3~

Technical features:

- Control input 0-10 VDC / PWM
- Output 10 VDC (+10 %) max. 10 mA
- Output 20 VDC (+/-20 %) max. 50 mA
- Output for slave 0-10 V max. 5 mA
- Input for sensor 0-10 V or 4-20 mA
- Operation and fault indicator
- Integrated PI controller
- Locked-rotor protection / Soft start / Motor current limitation
- RS 485 MODBUS-RTU / Alarm relay
- PFC, passive (standard) or PFC, active (see product-specific catalog page)
- Thermal overload protection for electronics/motor
- Undervoltage/phase failure detection
- Control interface with SELV potential safely disconnected from supply
- External enable input/External 24 V input (parameterization)

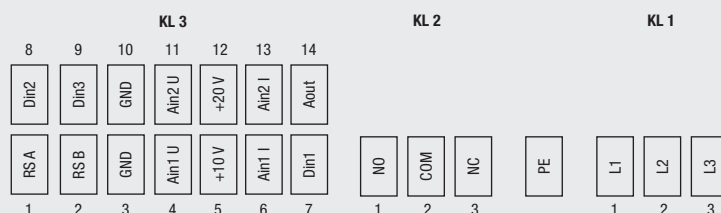

Terminal	Pin	Connection	Assignment/function
KL1	1	L1	Power supply, phase, see nameplate for voltage range
	2	L2	Power supply, phase, see nameplate for voltage range
	3	L3	Power supply, phase, see nameplate for voltage range
PE		PE	Protective earth
KL2	1	NO	Status relay, floating status contact, option 1: break for failure, option 2: break for run monitoring error message
	2	COM	Status relay, floating status contact, common connection, contact rating 250 VAC / 2 A (AC1) min. 10 mA, reinforced insulation on supply side and on control interface side
	3	NC	Status relay, floating status contact, option 1: make for failure, option 2: make for run monitoring error message
KL3	1	RSA	RS-485 interface for MODBUS RSA, SELV
	2	RSB	RS-485 interface for MODBUS RSB, SELV
	3/10	GND	Reference ground for control interface, SELV
	4	Ain1 U /PWM	Analog input 1 (set value); 0-10 V; Ri= 100 kΩ; adjustable curve; only for use as alternative to input Ain1 I, SELV
	5	+10 V	Voltage output, power supply for external devices (e.g. potentiometers), SELV
	6	Ain1 I	Analog input 1 (set value); 4-20 mA; Ri= 100 Ω; adjustable curve, only for use as alternative to input Ain1 U, SELV
	7	Din1	Digital input 1: Enable electronics; Enable: Pin open or applied voltage 5...50 VDC; Disable: Bridge to GND or applied voltage < 1 VDC; Reset function: Triggering of software reset after level change to < 1VDC, SELV
	8	Din2	Digital input 2: Switching parameter sets 1/2, according to EEPROM setting, the valid/used parameter set can be selected via bus or via digital input Din2. Parameter set 1: Pin open or applied voltage 5-50 VDC; Parameter set 2: Bridge to GND or applied voltage < 1 VDC, SELV
	9	Din3	Digital input 3: Direction of action of integrated controller; According to EEPROM setting, the direction of action of the integrated controller can be selected as normal/inverse via bus or digital input; Normal: Pin open or applied voltage 5...50 VDC; Inverse: Bridge or applied voltage < 1 VDC, SELV
	11	Ain2 U	Analog input 2; Measured value 0-10 V; Ri= 100 kΩ; adjustable curve; only for use as alternative to input Ain2 I, SELV
	12	+20 V	Voltage output, power supply for external devices (e.g. sensors), SELV
	13	Ain2 I	Analog input 2; Measured value 4-20 mA; Ri= 100 Ω; adjustable curve, only for use as alternative to input Ain2 U, SELV
	14	Aout	Analog output 0-10 V; max. 5 mA; output of current motor modulation level/current motor speed. Adjustable curve, SELV

Connection diagram: RP2)

M3G150, 3~

Technical features:

- Control input 0-10 VDC / PWM
- Output 10 VDC max. 10 mA
- RS 485 MODBUS-RTU / PFC, passive
- Thermal overload protection for electronics/motor
- Locked-rotor protection / Soft start
- Operation and fault indicator
- Integrated PI controller
- Motor current limitation / Alarm relay
- Undervoltage/phase failure detection
- Control interface with SELV potential safely disconnected from supply
- External enable input / External 24 V input (parameterization)

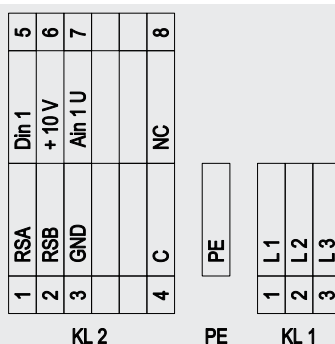

Terminal	Pin	Connection	Assignment/function
KL1	1	L1	Power supply, phase, see nameplate for voltage range
	2	L2	Power supply, phase, see nameplate for voltage range
	3	L3	Power supply, phase, see nameplate for voltage range
PE		PE	Protective earth
KL2	1	RSA	RS-485 interface for MODBUS RSA, SELV
	2	RSB	RS-485 interface for MODBUS RSB, SELV
	3	GND	Reference ground for control interface; SELV
	4	C	Status relay, floating status contact, contact rating 250 VAC / 2 A (AC1) min. 10 mA, reinforced insulation on supply side and on control interface side
	5	DIN1	Digital input 1 enable electronics, enable: pin open or applied voltage 5-50 VDC disable: bridge to GND or applied voltage < 1 VDC reset function: triggers software reset after a level change to < 1 V; SELV
	6	+10 V	Voltage output, power supply for external devices (e.g. potentiometers), SELV or: +24 VDC input for parameter setting via MODBUS without line voltage
	7	Ain 1 U	Analog input 1 (set value) 0-10 V, Ri = 100 kΩ, adjustable curve; SELV
	8	NC	Status relay, floating status contact, break for failure

Connection diagram: RP3)

M3G084, 1~

Technical features:

- Control input 0-10 VDC / PWM
- Output 10 VDC max. 10 mA
- Operation and fault indicator
- Alarm relay
- Locked-rotor protection, Soft start
- Power limiter
- PFC, active
- Motor current limitation
- RS 485 MODBUS-RTU
- Thermal overload protection for electronics/motor
- Undervoltage
- Control interface with SELV potential safely disconnected from supply

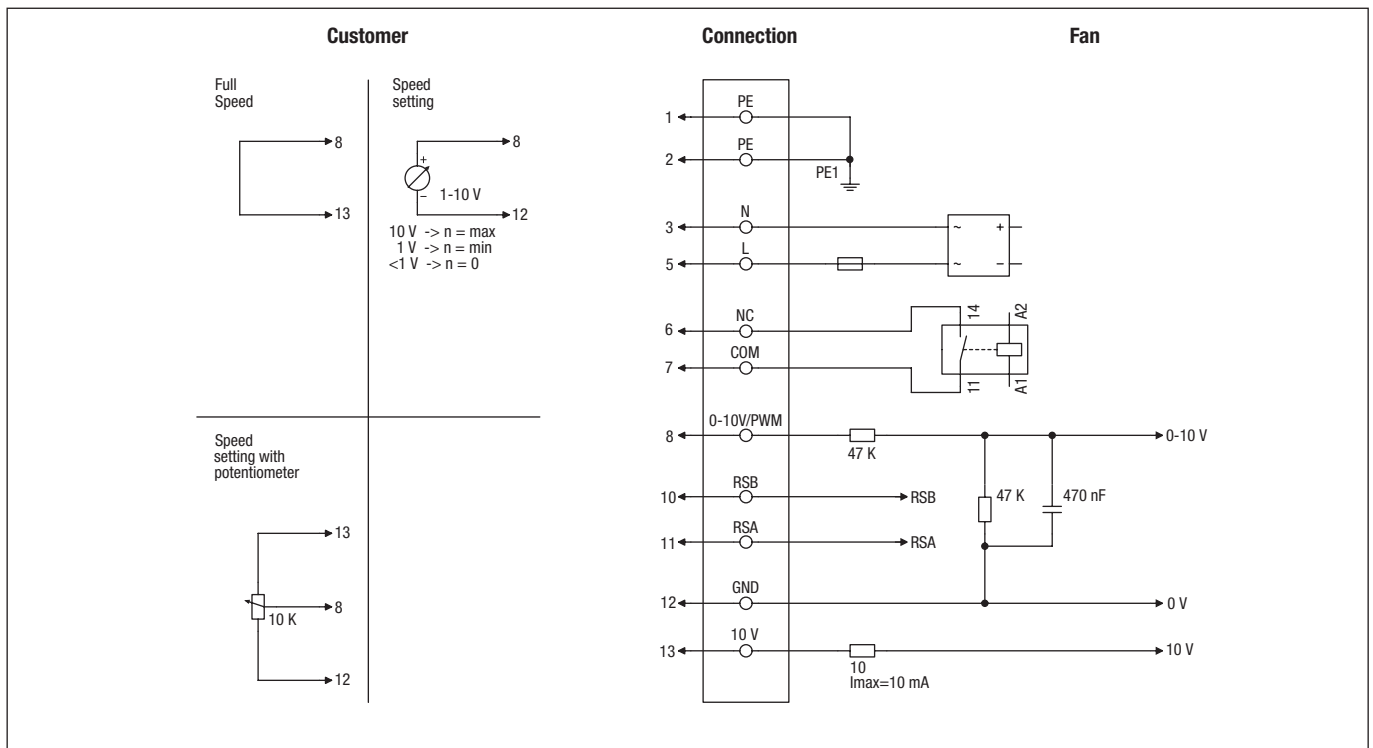

Wire	No.	Connection	Color	Assignment/function
1	1, 2	PE	green/yel.	Protective earth
1	3	N	blue	Power supply, neutral conductor, voltage range see nameplate
1	5	L	black	Power supply, phase, voltage range see nameplate
1	6	NC	white 1	Status relay, floating status contact, break for failure
1	7	COM	white 2	Status relay, floating status contact, contact rating 250 VAC / 2 A (AC1) min. 10 mA, basic insulation on supply side and reinforced insulation on control interface side
2	8	0-10 V / PWM	yellow	Control input 0-10 V or PWM, impedance 100 kΩ, SELV, adjustable curve
2	10	RSB	brown	RS485 interface for MODBUS, RSB, SELV
2	11	RSA	white	RS485 interface for MODBUS, RSA, SELV
2	12	GND	blue	Reference ground for control interface, SELV
2	13	+ 10 V / max. 10 mA	red	Voltage output, power supply for ext. devices (e.g. potentiometer), SELV

Connection diagram: RP4)

M3G084 & M3G112, 3~

Technical features:

- Control input 0-10 VDC / PWM
- Output 10 VDC max. 10 mA
- Operation and fault indicator
- Integrated PI controller
- Alarm relay
- Locked-rotor protection, Soft start
- PFC, passive
- Motor current limitation
- RS 485 MODBUS-RTU
- Thermal overload protection for electronics/motor
- Undervoltage/phase failure detection
- External 24 V input (parameterization)
- Control interface with SELV potential safely disconnected from supply

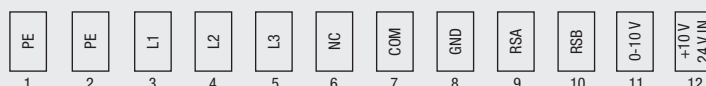

No.	Connection	Assignment/function
1, 2	PE	Protective earth
3	L1	Power supply, phase, see nameplate for voltage range
4	L2	Power supply, phase, see nameplate for voltage range
5	L3	Power supply, phase, see nameplate for voltage range
6	NC	Status relay, floating status contact, break for failure
7	COM	Status relay, floating status contact, contact rating 250 VAC / 2 A (AC1) min. 10 mA, basic insulation on supply side and reinforced insulation on control interface side
8	GND	Reference ground for control interface, SELV
9	RSA	RS-485 interface for MODBUS RSA, SELV
10	RSB	RS-485 interface for MODBUS RSB, SELV
11	0-10 V / PWM	Control input 0-10 V or PWM, impedance 100 k Ω , SELV, adjustable curve
12	+10 V	Voltage output, power supply for external devices (e.g. potentiometers), SELV or: +24 VDC input for parameter setting via MODBUS without line voltage

Connection diagram: RP5)

M3G084, 3~

Technical features:

- Control input 0-10 VDC / PWM
- Input for sensor 0-10 V or 4-20 mA
- Output for slave 0-10 V max. 3 mA
- Output 20 VDC (+25 %/-10 %) max. 50 mA
- Output 10 VDC (+/-3 %) max. 10 mA
- Integrated PI controller
- PFC, passive
- Motor current limitation, Alarm relay
- RS 485 MODBUS-RTU
- Thermal overload protection for electronics/motor
- Undervoltage/phase failure detection
- Locked-rotor protection, Soft start
- External 24 V input (parameterization)
- Control interface with SELV potential safely disconnected from supply



Terminal	Connection	Assignment/function
PE	PE	Protective earth
KL1	L3	Power supply, phase, see nameplate for voltage range
	L2	Power supply, phase, see nameplate for voltage range
	L1	Power supply, phase, see nameplate for voltage range
KL2	NC	Status relay, floating status contact, option 1: break for failure, option 2: break for run monitoring error message
	COM	Status relay, floating status contact, common connection, contact rating 250 VAC / 2 A (AC1) min. 10 mA, reinforced insulation on supply side and on control interface side
	NO	Status relay, floating status contact, option 1: make for failure, option 2: make for run monitoring error message
KL3	OUT	Analogue output 0-10 VDC max. 3 mA, SELV; Output of the actual motor duty cycle (PWM): 1 V corresponds to 10 % PWM, 10 V correspond to 100 % PWM.
	GND	Reference ground for control interface, SELV
	0-10 V / PWM	Control input/current sensor value input 0-10 VDC, (impedance 100 kΩ), only for use as alternative to input 4-20 mA, SELV
	+10 V	Voltage output, power supply for external devices (e.g. potentiometers), SELV
	+20 V	Voltage output, power supply for external devices (e.g. sensors), SELV or: +24 VDC input for parameter setting via MODBUS without line voltage
	4-20 mA	Control input/current sensor value input 4-20 mA, (Impedanz 100 Ω), only for use as alternative to input 0-10 V, SELV
	0-10 V / PWM	Control input/current sensor value input 0-10 VDC, (Impedanz 100 kΩ), only for use as alternative to input 4-20 mA, SELV
	GND	Reference ground for control interface, SELV
	RSB	RS-485 interface for MODBUS RSB, SELV
	RSA	RS-485 interface for MODBUS RSA, SELV
	RSB	RS-485 interface for MODBUS RSB, SELV
RSA	RS-485 interface for MODBUS RSA, SELV	

Connection diagram: RP6)

M3G150, 3~

Technische Ausstattung:

- Configurable inputs/outputs (I/O)
- RFID - ISO 15693 compatible
- Operation and alarm display with LED
- Integrated PI controller
- Locked-rotor protection
- Motor current limitation / Alarm relay
- Soft start
- Voltage output 3.3-24 VDC, Pmax = 800 mW
- RS 485 MODBUS-RTU / MODBUS V6
- Thermal overload protection for electronics/motor
- Undervoltage/phase failure detection
- Control interface with SELV potential safely disconnected from supply
- External 15-50 VDC input (parameterization)

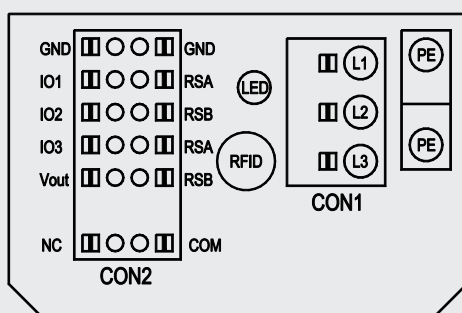

No.	Connection	Assignment/function
CON1	L1, L2, L3	Power supply, phase, see nameplate for voltage range
PE	PE	Protective earth
CON2	RSA	RS-485 interface for MODBUS RSA, SELV
CON2	RSB	RS-485 interface for MODBUS RSB, SELV
CON2	GND	Reference ground for control interface, SELV
CON2	IO1	IN2: Digital input - positive logic (factory setting: Enable) function parameterizable, SELV - normal: Pin open or applied voltage < 1.5 VDC - inverse: applied voltage 3.5-50 VDC
CON2	IO2	IN1: Analog input 0-10 V 0-10 V, Ri=100 K, parameterizable as set value or measured value (factory setting: set value) characteristic curve parameterizable, SELV
CON2	IO3	OUT1: Analog output 0-10 V 0-10 V, max 5 mA, function parameterizable (factory setting: modulation level) max output frequency 300 Hz, SELV
CON2	Vout	Voltage output 3.3-24 VDC +/-5%, Pmax=800 mW, voltage parameterizable (factory setting: 10 VDC) short-circuitproof, supply for external devices, SELV alternatively: 15-50 VDC input for parameterization via Modbus without line voltage
CON2	COM	Status relay, floating status contact, contact rating 250 VAC / 2 A (AC1) min. 10 mA, reinforced insulation on supply side and on control interface side
CON2	NC	Status relay, floating status contact, option 1: break for failure, option 2: break for run monitoring error message

Connection diagram: RP7)

M3G150, 3~

Technical features:

- Control input 0-10 VDC / PWM
- Output 10 VDC max. 10 mA
- Output 20 VDC max. 50 mA
- Output for slave 0-10 V
- Input for sensor 0-10 V or 4-20 mA
- Operation and fault indicator
- Integrated PI controller
- Alarm relay
- Locked-rotor protection / Soft start
- Motor current limitation
- RS 485 MODBUS-RTU / PFC, passive
- Thermal overload protection for electronics/motor
- Undervoltage/phase failure detection
- External enable input / External 24 V input (parameterization)

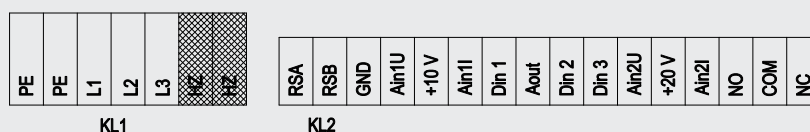

Shaded => terminals not used

Terminal	Connection	Assignment/function
KL1	PE	Protective earth
	L1	Power supply, phase, see nameplate for voltage range
	L2	Power supply, phase, see nameplate for voltage range
	L3	Power supply, phase, see nameplate for voltage range
	HZ	not used (optional: internal heating element)
KL2	RSA	RS-485 interface for MODBUS RSA, SELV
	RSB	RS-485 interface for MODBUS RSB, SELV
	GND	Reference ground for control interface (SELV)
	Ain1 U	Analog input 1, set value: 0-10 V, Ri = 100 kΩ, adjustable curve, only usable as alternative to input Ain1I; SELV
	+10 V	Voltage output, power supply for external devices (e.g. potentiometers), SELV
	Ain1 I	Analog input 1, set value: 4-20 mA, Ri = 100 Ω, adjustable curve, only usable as alternative to input Ain1U; SELV
	Din 1	Digital input 1: enable electronics, enable: pin open or applied voltage 5-50 VDC disable: bridge to GND or applied voltage < 1 VDC reset function: triggers software reset after a level change to < 1 VDC; SELV
	Aout	Analog output 0-10 VDC, max. 5 mA, output of current motor modulation level / motor speed adjustable curve; SELV
	Din 2	Digital input 2: Switching parameter sets 1/2, according to EEPROM setting, the valid or used parameter set can be selected via bus or via digital input DIN2. Parameter set 1: pin open or applied voltage 5-50 VDC Parameter set 2: bridge to GND or applied voltage < 1 VDC; SELV
	Din 3	Digital input 3: Direction of action of integrated controller, according to EEPROM setting, the direction of action of the integrated controller can be selected as normal/inverse via bus or digital input Normal: Pin open or applied voltage 5-50 VDC; Inverse: Bridge to GND or applied voltage < 1 VDC; SELV
	Ain2 U	Analog input 2, measured value: 0-10 V, Ri = 100 kΩ, adjustable curve, only usable as alternative to input Ain2 I; SELV
	+20 V	Voltage output, power supply for external devices (e.g. sensors), SELV or: +24 VDC input for parameter setting via MODBUS without line voltage
	Ain2 I	Analog input 2, measured value: 4-20 mA, Ri = 100 Ω, adjustable curve, only usable as alternative to input Ain2 U; SELV
	NO	Status relay, floating status contact, option 1: make for failure, option 2: make for run monitoring error message
	COM	Status relay, floating status contact, common connection, contact rating 250 VAC / 2 A (AC1) min. 10 mA, reinforced insulation on supply side and on control interface side
NC	Status relay, floating status contact, option 1: break for failure, option 2: break for run monitoring error message	

Agents	Technology	ATEX version	Compact version	Short version	Ø 1000	Ø 800	Ø 710	Ø 630	Ø 560	Ø 500	Ø 450	Ø 400	Ø 355	Ø 310	Ø 280	Ø 250	Information
--------	------------	--------------	-----------------	---------------	--------	-------	-------	-------	-------	-------	-------	-------	-------	-------	-------	-------	-------------



ebm-papst FanScout

Click your way to the ideal RadiPac



ebm-papst FanScout

Click your way to the ideal RadiPac

With the FanScout selection software from ebm-papst, you can quickly and easily find the ideal product for your exact requirements from our extensive product range.

Fans operated in parallel, so-called FanGrids, are also included in the selection.

The software can be easily integrated into your device configuration program using the DLL interface.

Since our software is based on real measured values, the data you get with ebm-papst FanScout will always be absolutely reliable and above all extremely accurate.

This has been confirmed by TÜV SÜD, the German technical service organization. It assigned the accuracy of FanScout's calculations in comparison with real measurements to the highest class.

In a short time, not only can you find the best solution for your use case, you can also simulate various operating scenarios that take the fans' operating points, operating times and space requirements into account to provide you with an estimate of annual energy consumption.

To make the decision even easier for you, ebm-papst FanScout also takes life cycle costs into account: the purchase price and the operating and service costs.

ebm-papst FanScout is available to our customers only.

Please contact your ebm-papst representative or call us at +49 7938 81-0.

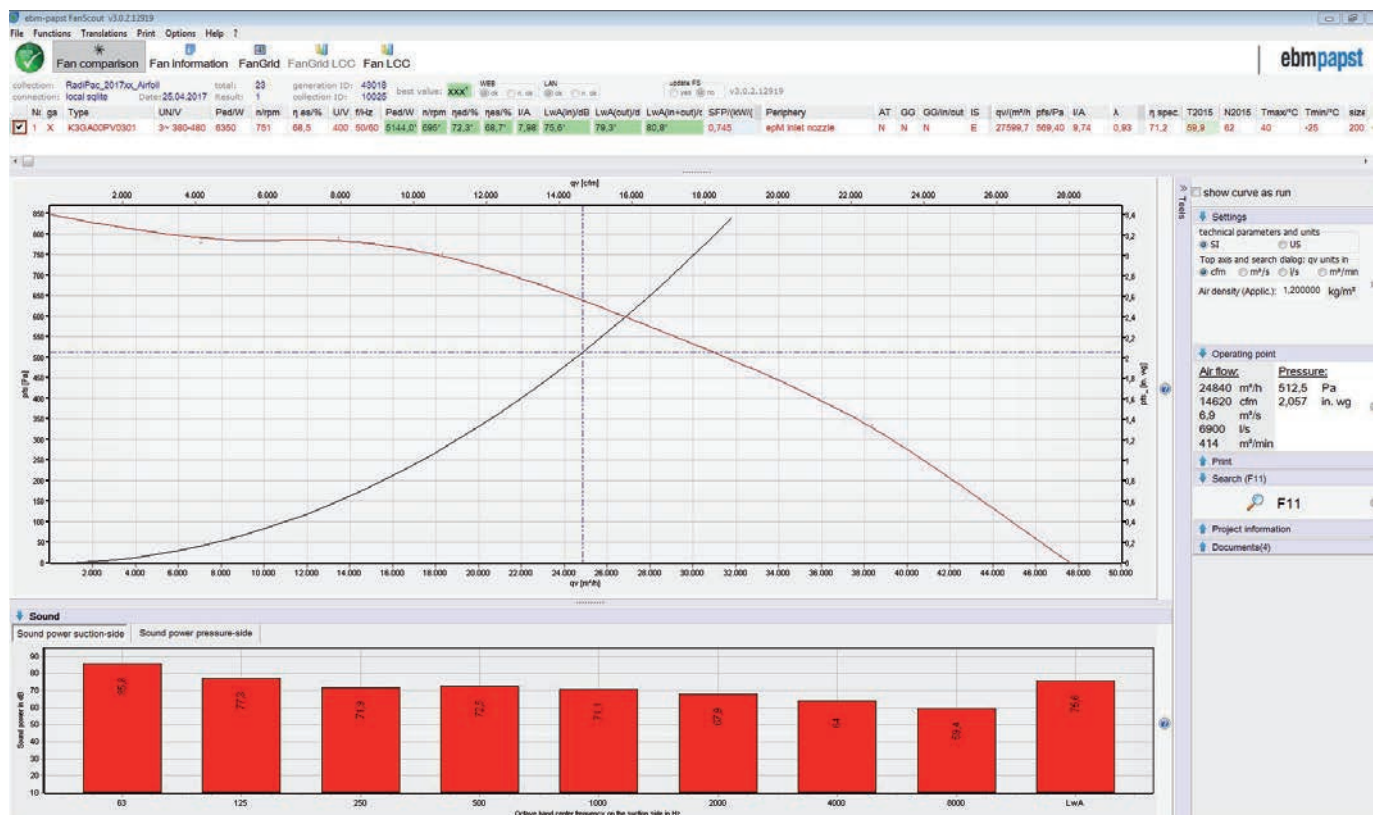

Technical parameters and scope

High standards for all ebm-papst products

At ebm-papst we are always looking to improve our products to be able to offer customers just what they need for their particular requirements. Careful monitoring of the market enables us to constantly incorporate enhancements into our products. As shown by the technical parameters listed below, you can always be sure of finding the right solution from ebm-papst for whatever application you may have in mind.

General performance parameters

Any deviations from the technical data and technical parameters described here are given in the product-specific data sheet.

Degree of protection

The degree of protection is specified in the product-specific data sheets.

Insulation class

The insulation class is specified in the product-specific data sheets.

Installation position

The installation position is specified in the product-specific data sheets.

Condensation drainage holes

Information on condensation drainage holes is provided in the product-specific data sheets.

Mode of operation

The mode of operation is specified in the product-specific data sheets.

Protection class

The protection class is specified in the product-specific data sheets.

Service life

The service life of ebm-papst products depends on two main factors:

- The service life of the insulation system
- The service life of the bearing system

The service life of the insulation system is essentially governed by the voltage level, the temperature and the ambient conditions such as humidity and condensation.

The service life of the bearing system is primarily governed by the thermal load on the bearings. For the majority of our products we use maintenance-free ball bearings which can be fitted in any installation position. Sleeve bearings can alternatively be employed, as described in the product-specific data sheets.

As a rough guide (depending on the general conditions), the ball bearings have a life expectancy L10 of approx. 40,000 hours of operation at an ambient temperature of 40 °C.

We will gladly provide you with a life expectancy calculation based on your specific usage conditions.

Motor protection/thermal protection

Information on motor protection and thermal protection is provided in the product-specific data sheets.

The following protection methods are provided depending on the type of motor and area of application:

- Thermal overload protector, in-circuit or external
- PTC with electronic diagnostics
- Impedance protection
- Thermal overload protector with electronic diagnostics
- Current limitation via electronics

If use is made of an external thermal overload protector, a commercially available tripping unit must be connected by the customer for shut-off.

Motor protection conforming to the applicable standard must be fitted for products not provided with a built-in thermal overload protector and not protected against improper use.

Mechanical strain/performance parameters

All ebm-papst products are subjected to comprehensive testing in conformity with the normative specifications and also incorporating the extensive experience of ebm-papst.

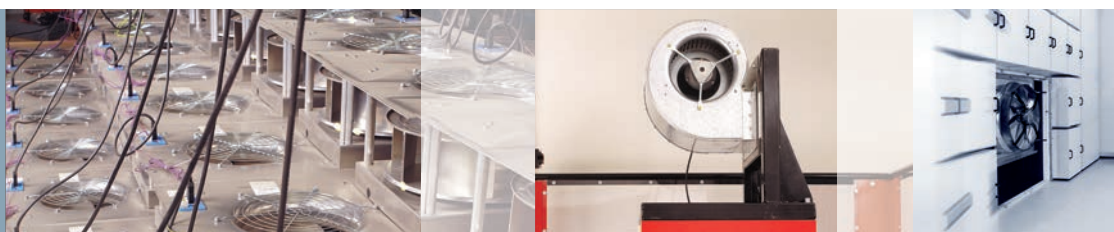

Vibration testing

Vibration testing is performed as follows:

- Vibration test in operation according to DIN IEC 68 Part 2-6
- Vibration test at standstill according to DIN IEC 68 Part 2-6

Shock load

Shock load testing is performed as follows:

- Shock load according to DIN IEC 68 Part 2-27

Balancing grade

Balancing grade testing is performed as follows:

- Residual imbalance according to DIN ISO 1940
- Standard balancing quality level G 6.3

Should your particular application require a higher level of balancing, please contact us and specify the details in your order.

Chemical and physical strain/performance parameters

Please consult your ebm-papst contact for any questions regarding chemical and physical strain.

Areas of use, industries & applications

Our products are used in a variety of industries and for numerous applications:

Ventilation, air conditioning and refrigeration technology, clean room technology, automotive and railway engineering, medical and laboratory technology, electronics, computer and office systems, telecommunications, household appliances, heating systems, machinery and installations, drive engineering.

Our products are not intended for use in the aerospace industry!

Legal and normative specifications

The products described in this catalog are developed and manufactured in accordance with the standards applying to the particular product and, if known, in accordance with the conditions of the particular area of application.

Standards

Information on standards is provided in the product-specific data sheets.

EMC

Information on EMC standards is provided in the product-specific data sheets.

Compliance with EMC standards has to be assessed on the final product, as EMC properties may change under different installation conditions.

Touch current

Information on touch current is provided in the product-specific data sheets.

Measurement is performed according to IEC 60990.

Approvals

Please contact us if you require a specific type of approval (VDE, UL, GOST, CCC, CSA, etc.) for your ebm-papst product.

Most of our products can be supplied with the applicable approval.

Information on existing approvals is provided in the product-specific data sheets.

Air performance measurements

All air performance measurements are conducted on intake-side chamber test rigs conforming to the requirements of ISO 5801 and DIN 24163. The fans under test are attached to the measuring chamber with free air intake and exhaust (installation category A) and operated at nominal voltage, with alternating current also at nominal frequency, without any additional attachments such as a guard grill.

As required by the standards, the air performance curves shown are referenced to an air density of 1.15 kg/m³.

Technical parameters and scope



Air and sound measurement conditions

Measurements on ebm-papst products are taken under the following conditions:

- Axial and diagonal fans in airflow direction “V” in full nozzle without guard grill
- Backward-curved centrifugal fans, free-running with inlet ring
- Forward-curved single and dual-inlet centrifugal fans with housing
- Backward-curved dual-inlet centrifugal fans with housing

Sound measurements

All sound measurements are taken in anechoic rooms with reverberant floor. ebm-papst acoustic test chambers meet the requirements of accuracy class 1 as per DIN EN ISO 3745. For sound measurement, the fans being tested are positioned in a reverberant wall and operated at nominal voltage, with alternating current also at nominal frequency, without any additional attachments such as a guard grill.

Sound pressure and sound power level

All acoustic values are determined in accordance with ISO 13347, DIN 45635 and ISO 3744/3745 as per accuracy class 2 and given in A-rated form.

For measurement of the sound pressure level L_p the microphone is located on the intake side of the fan being tested, generally at a distance of 1 m on the fan axis.

For measurement of the sound power level L_W 10 microphones are distributed over an enveloping surface on the intake side of the fan being tested (see graphic). The measured sound power level can be roughly calculated from the sound pressure level by adding 7 dB.

Measurement set-up according to ISO 13347-3 and DIN 45635-38:

- 10 measuring points

$d \geq D$

$h = 1.5d \dots 4.5d$

Measurement area $S = 6d^2 + 7d(h + 1.5d)$

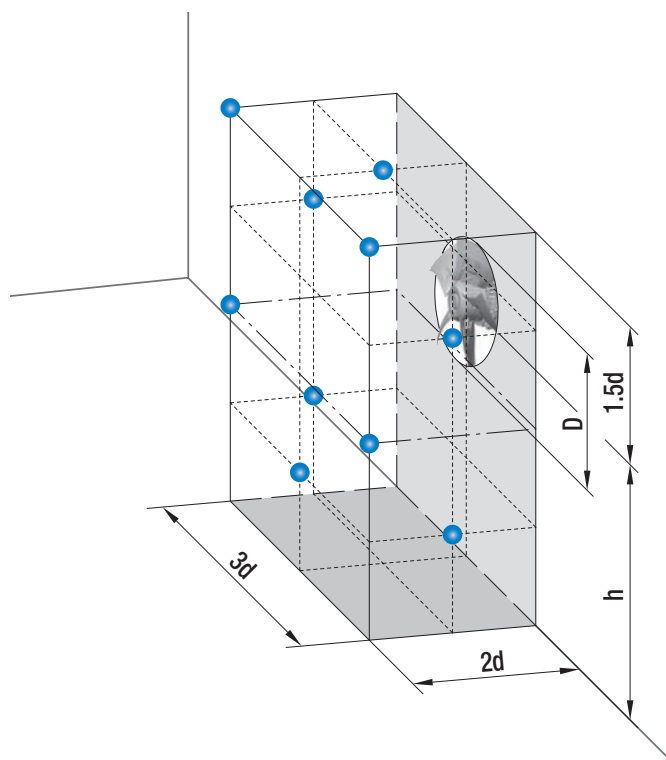

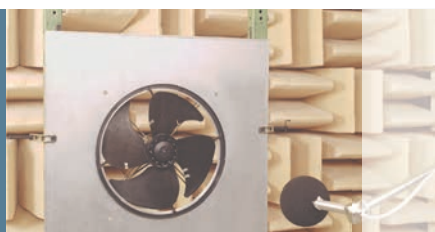

Cumulative level of several sound sources with the same level

The addition of 2 sound sources with the same level produces a level increase of approx. 3 dB. The noise characteristics of several identical fans can be predicted on the basis of the sound values specified in the data sheet. This is shown in the adjacent graph.

Example: There are 8 axial fans A3G800 on a condenser. According to the data sheet, the sound pressure level of one fan is 75 dB(A). The level increase determined from the graph is 9 dB. This means that a total level of 84 dB(A) is to be expected for the installation.

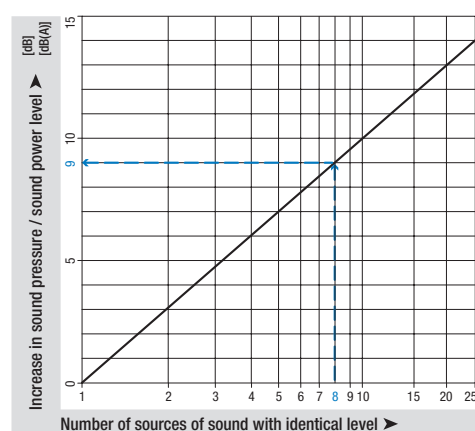

Cumulative level of two sound sources with different levels

The noise characteristics of two different fans can be predicted on the basis of the sound values specified in the data sheet. This is shown in the adjacent graph.

Example: In a ventilation unit, there is one axial fan A3G800 with a sound pressure level of 75 dB(A) at the point of operation and one axial fan A3G710 with 71 dB(A). The difference in level is 4 dB. The level increase of approx. 1.5 dB can now be read off the graph. This means that a total level of 76.5 dB(A) is to be expected for the unit.

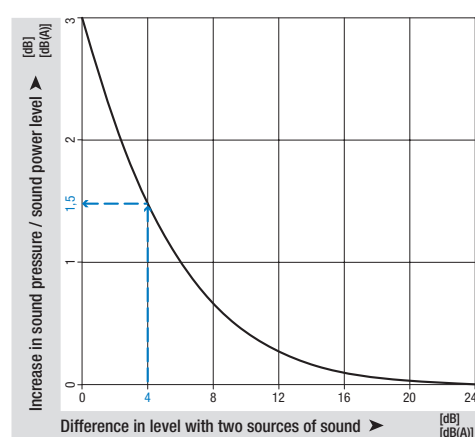

Distance laws

The sound power level is not governed by the distance from the noise source. By contrast, the sound pressure level decreases with increasing distance from the sound source. The adjacent graph shows the decrease in level under far field conditions. Far field conditions apply if there is a considerable distance between the microphone and the fan in relation to the fan diameter and the wavelength under consideration. On account of the complexity of the topic, literature should be consulted for more detailed information on far fields. The level in the far field decreases by 6 dB each time the distance is doubled. Different relationships apply in the near field of the fan and the level may decrease to a far lesser extent. The following example only applies to far field conditions and may vary considerably as a result of installation effects:

For an axial fan A3G300, a sound pressure level of 65 dB(A) was measured at a distance of 1 m. From the adjacent graph, this would yield a reduction of 26 dB at a distance of 20 m, i.e. a sound pressure level of 39 dB(A).

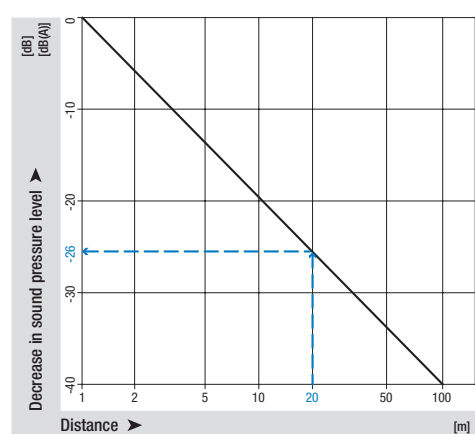

ebm-papst in Germany

ebm-papst Mulfingen GmbH & Co. KG

Bachmühle 2
74673 Mulfingen
GERMANY
Phone +49 7938 81-0
Fax +49 7938 81-110
info1@de.ebmpapst.com

ebm-papst St. Georgen GmbH & Co. KG

Hermann-Papst-Straße 1
78112 St. Georgen
GERMANY
Phone +49 7724 81-0
Fax +49 7724 81-1309
info2@de.ebmpapst.com

ebm-papst Landshut GmbH

Hofmark-Aich-Straße 25
84030 Landshut
GERMANY
Phone +49 871 707-0
Fax +49 871 707-465
info3@de.ebmpapst.com

 **Berlin**
Dipl.-Ing. (TH) Jens Duchow
Händelstraße 7
16341 Panketal
GERMANY
Phone +49 30 944149-62
Fax +49 30 944149-63
Jens.Duchow@de.ebmpapst.com

 **Bielefeld**
Dipl.-Ing. (FH) Wolf-Jürgen Weber
Niehausweg 13
33739 Bielefeld
GERMANY
Phone +49 5206 91732-31
Fax +49 5206 91732-35
Wolf-Juergen.Weber@de.ebmpapst.com

 **Dortmund**
Dipl.-Ing. (FH) Hans-Joachim Pundt
Auf den Steinern 3
59519 Möhnese-Völlinghausen
GERMANY
Phone +49 2925 800-407
Fax +49 2925 800-408
Hans-Joachim.Pundt@de.ebmpapst.com

 **Frankfurt**
Dipl.-Ing. Christian Kleffmann
Dr.-Hermann-Krause-Straße 23
63452 Hanau
GERMANY
Phone +49 6181 1898-12
Fax +49 6181 1898-13
Christian.Kleffmann@de.ebmpapst.com

 **Halle**
Dipl.-Ing. (TU) Michael Hanning
Lercheneck 4
06198 Salztal / OT Lieskau
GERMANY
Phone +49 345 55124-56
Fax +49 345 55124-57
Michael.Hanning@de.ebmpapst.com

 **Hamburg**
Ingenieurbüro Breuell GmbH
Ing. Dirk Kahl
Elektroingenieur
Oststraße 96
22844 Norderstedt
GERMANY
Phone +49 40 538092-19
Fax +49 40 538092-84
Kahl@breuell-hilgenfeldt.de

 **Heilbronn / Heidelberg**
Dipl.-Ing. Mark Gartner
Gehweg 12
74199 Unterheinriet
GERMANY
Phone +49 7130 404569-1
Fax +49 7130 404569-2
Mark.Gartner@de.ebmpapst.com

 **Kassel**
Dipl.-Ing. (FH) Ralph Brück
Hoherainstraße 3 b
35075 Gladenbach
GERMANY
Phone +49 6462 4071-10
Fax +49 6462 4071-11
Ralph.Brueck@de.ebmpapst.com

 **Koblenz**
Winfried Schaefer
Hinter der Kirch 10
56767 Uersfeld
GERMANY
Phone +49 2657 16-96
Fax +49 2657 16-76
Winfried.Schaefer@de.ebmpapst.com

 **Munich**
Dipl.-Wirt.-Ing. (FH) Jens Peter
Landsbergerstraße 14
86932 Pürgen
GERMANY
Phone +49 8196 99877-54
Fax +49 8196 99877-55
Jens.Peter@de.ebmpapst.com

 **Nuremberg**
Dipl.-Wirt.-Ing. (FH) Axel Resch
Dr.-August-Koch-Str. 1
91639 Wolfraams-Eschenbach
GERMANY
Phone +49 9875 9783-170
Fax +49 9875 9783-171
Axel.Resch@de.ebmpapst.com

 **Offenburg**
Dipl.-Ing. (FH) Ralf Braun
Hubeneck 21
77704 Oberkirch
GERMANY
Phone +49 7802 9822-52
Fax +49 7802 9822-53
Ralf.Braun@de.ebmpapst.com

 **Stuttgart**
Dipl.-Ing. (FH) Rudi Weinmann
Hindenburgstraße 100/1
73207 Plochingen
GERMANY
Phone +49 7153 9289-80
Fax +49 7153 9289-81
Rudi.Weinmann@de.ebmpapst.com

 **Ulm**
M.Sc. Reinhard Sommerreißer
Am Germanenring 13
86674 Baar / Schwaben
GERMANY
Phone +49 8276 5899-775
Fax +49 8276 5899-776
Reinhard.Sommerreisser@de.ebmpapst.com

Distributors

 **Frankfurt**
R.E.D. Handelsgesellschaft mbH
Gutenbergstraße 3
63110 Rodgau - Jügesheim
GERMANY
Phone +49 6106 841-0
Fax +49 6106 841-111
info@red-elektromechanik.de
www.red-elektromechanik.de

 **Hamburg**
Breuell + Hilgenfeldt GmbH
Oststraße 96
22844 Norderstedt
GERMANY
Phone +49 40 538092-20
Fax +49 40 538092-84
info@breuell-hilgenfeldt.de

 **Munich**
A. Schweiger GmbH
Ohmstraße 1
82054 Sauerlach
GERMANY
Phone +49 8104 897-0
Fax +49 8104 897-90
info@schweiger-gmbh.de
www.schweiger-gmbh.com

● **Express Service-Center** (1 to 5 pieces)

 **North**
Breuell + Hilgenfeldt GmbH
Oststraße 96
22844 Norderstedt
GERMANY
Phone +49 40 538092-20
Fax +49 40 538092-84
info@breuell-hilgenfeldt.de

 **South**
HDS Ventilatoren Vertriebs GmbH
Glaswiesenstraße 1
74677 Dörzbach
GERMANY
Phone +49 7937 80355-20
Fax +49 7937 80355-25
info@hds-gmbh.net
www.hds-gmbh.net

ebm-papst in Europe



Europe



Austria

ebm-papst Motoren & Ventilatoren GmbH
Straubingstraße 17
4030 Linz
AUSTRIA
Phone +43 732 321150-0
Fax +43 732 321150-20
info@at.ebmpapst.com
www.ebmpapst.at



Belarus

ebm-papst Bel AgmbH
4th Montazhnikov side street
House 6, Office 332
BY-220019 Minsk
BELARUS
Phone +375 17 2015216
Fax +375 17 2015216
info@by.ebmpapst.com
www.ebmpapst.by



Belgium

ebm-papst Benelux B.V.
Sales office Belgium-Luxemburg
Romeinsestraat 6/0101
Research Park Haasrode
3001 Heverlee-Leuven
BELGIUM
Phone +32 16 396-200
Fax +32 16 396-220
info@be.ebmpapst.com
www.ebmpapst.be



Bulgaria

ebm-papst Romania P.R.L.
Str. Tarnavei No. 20
500327 Brasov
ROMANIA
Phone +40 268 331859
Fax +40 268 312805
dudasludovic@xnet.ro



Croatia

ebm-papst Industries Kft.
Ezred u. 2.
1044 Budapest
HUNGARY
Phone +36 1 8722-190
Fax +36 1 8722-194
office@hu.ebmpapst.com



Cyprus

Helcoma
E. Rota and Co. OE
Davaki 65
17672 Kallithea-Attiki
GREECE
Phone +30 210 9513-705
Fax +30 210 9513-490
contact@helcoma.gr
www.helcoma.gr



Czech Republic / Slovakia

ebm-papst CZ s.r.o.
Kaštanová 34a
620 00 Brno
CZECH REPUBLIC
Phone +420 544 502-411
Fax +420 547 232-622
info@ebmpapst.cz
www.ebmpapst.cz



Denmark

ebm-papst Denmark ApS
Vallensbækvej 21
2605 Brøndby
DENMARK
Phone +45 43 631111
Fax +45 43 630505
mail@dk.ebmpapst.com
www.ebmpapst.dk



Estonia

ebm-papst Oy, Eesti Filiaal
Kesk tee 21
Aaviku küla, Jüri Tehnopark
75301 Rae Vald, Harjumaa
ESTONIA
Phone +372 65569-78
www.ebmpapst.ee



Finland

ebm-papst Oy
Puistotie 1
02760 Espoo
FINLAND
Phone +358 9 887022-0
Fax +358 9 887022-13
mailbox@ebmpapst.fi
www.ebmpapst.fi



France

ebm-papst sarl
Parc d'Activités Nord
1 rue Mohler – BP 62
67212 Obernai Cedex
FRANCE
Phone +33 3 88 66 88 03
info@ebmpapst.fr
www.ebmpapst.fr



Greece

Helcoma
E. Rota and Co. OE
Davaki 65
17672 Kallithea-Attiki
GREECE
Phone +30 210 9513-705
Fax +30 210 9513-490
contact@helcoma.gr
www.helcoma.gr



Hungary

ebm-papst Industries Kft.
Ezred u. 2.
1044 Budapest
HUNGARY
Phone +36 1 8722-190
Fax +36 1 8722-194
office@hu.ebmpapst.com



Iceland

RJ Engineers
Stangarhyl 1a
110 Reykjavik
ICELAND
Phone +354 567 8030
Fax +354 567 8015
rj@rj.is
www.rj.is



Ireland

ebm-papst UK Ltd.
Chelmsford Business Park
Chelmsford Essex CM2 5EZ
UNITED KINGDOM
Phone +44 1245 468555
Fax +44 1245 466336
sales@uk.ebmpapst.com
www.ebmpapst.co.uk



AuBren Limited

Portlaoise Business & Technology Park
Mountrath Road
Portlaoise, Co. Laois
IRELAND
Phone +353 57 8664343
Fax +353 57 8664346
sales@ie.aubren.com
www.aubren.com



Italy

ebm-papst Srl
Via Cornaggia 108
22076 Mozzate (Co)
ITALY
Phone +39 0331 836201
Fax +39 0331 821510
info@it.ebmpapst.com
www.ebmpapst.it

ebm-papst in Europe



 **Macedonia**
ebm-papst Industries Kft.
Ezred u. 2.
1044 Budapest
HUNGARY
Phone +36 1 8722-190
Fax +36 1 8722-194
office@hu.ebmpapst.com

 **Netherlands**
ebm-papst Benelux B.V.
Polbeemd 7 - 5741 TP Beek en Donk
P.O. Box 140 - 5740 AC Beek en Donk
NETHERLANDS
Phone +31 492 502-900
Fax +31 492 502-950
verkoop@nl.ebmpapst.com
www.ebmpapst.nl

ebm-papst Heating Systems B.V.
Van Veldekekade 360
5216 KT 's-Hertogenbosch
NETHERLANDS
Phone +31 73 648 89 00
Fax +31 73 648 89 11
info@ebmpapst-hs.nl
www.ebmpapst-hs.nl

 **Norway**
ebm-papst AS
P.B. 173 Holmlia
1203 Oslo
NORWAY
Phone +47 22 763340
Fax +47 22 619173
mailbox@ebmpapst.no
www.ebmpapst.no

 **Poland**
ebm-papst Polska Sp. z o.o.
ul. Annopol 4A
03236 Warszawa
POLAND
Phone +48 22 6757819
Fax +48 22 6769587
office@ebmpapst.pl
www.ebmpapst.pl

 **Portugal**
ebm-papst (Portugal), Lda.
Centro Empresarial de Alverca
Rua de Adarse, Vale D'Ervas
Corpo D / Fracção 3
2615-178 Alverca do Ribatejo
PORTUGAL
Phone +351 218 394 880
Fax +351 218 394 759
info@pt.ebmpapst.com
www.ebmpapst.pt

 **Romania**
ebm-papst Romania S.R.L.
Str. Tarnavei Nr. 20
500327 Brasov
ROMANIA
Phone +40 268 331859
Fax +40 268 312805
dudasludovic@xnet.ro

 **Russia**
ebm-papst Rus GmbH
Olimpiyskiy prospect 29A, office 418
141006 Mytistschi, Oblast Moskau
RUSSIA
Phone +7 495 9807524
Fax +7 495 5140924
info@ebmpapst.ru
www.ebmpapst.ru

 **Russia**
ebm-papst Ural GmbH
Posadskaja-Strasse, 23(E), 3
620102 Ekaterinburg
RUSSIA
Phone +7 343 2338000
Fax +7 343 2337788
Konstantin.Molokov@ru.ebmpapst.com
www.ebmpapst.ru

 **Serbia & Montenegro**
ebm-papst Industries Kft.
Ezred u. 2.
1044 Budapest
HUNGARY
Phone +36 1 8722-190
Fax +36 1 8722-194
office@hu.ebmpapst.com

 **Spain**
ebm-papst Ibérica S.L.
Avda. del Sistema Solar, 29
28830 San Fernando de Henares (Madrid)
SPAIN
Phone +34 91 6780894
Fax +34 91 6781530
ventas@ebmpapst.es
www.ebmpapst.es

 **Sweden**
ebm-papst AB
Äggelundavägen 2
17562 Järfälla
SWEDEN
Phone +46 10 4544400
Fax +46 8 362306
info@ebmpapst.se
www.ebmpapst.se

 **Switzerland**
ebm-papst AG
Rütisbergstrasse 1
8156 Oberhasli
SWITZERLAND
Phone +41 44 73220-70
Fax +41 44 73220-77
verkauf@ebmpapst.ch
www.ebmpapst.ch

 **Turkey**
Akantel Elektronik San. Tic. LTD. Sti.
Atatürk Organize Sanayi
Bölgesi 10007 SK. No.:6
35620 Cigli-Izmir
TURKEY
Phone +90 232 3282090
Fax +90 232 3280270
akantel@akantel.com.tr
www.ebmpapst.com.tr

 **Ukraine**
ebm-papst Ukraine LLC
Lepse Boulevard, 4, Building 21
03067 Kiev
UKRAINE
Phone +38 044 2063091
Fax +38 044 2063091
mail@ebmpapst.ua
www.ebmpapst.ua

 **United Kingdom**
ebm-papst UK Ltd.
Chelmsford Business Park
Chelmsford Essex CM2 5EZ
UNITED KINGDOM
Phone +44 1245 468555
Fax +44 1245 466336
sales@uk.ebmpapst.com
www.ebmpapst.co.uk

 **United Kingdom**
ebm-papst Automotive & Drives (UK) Ltd.
The Smithy
Fidlers Lane
East Ilsley, Berkshire RG20 7LG
UNITED KINGDOM
Phone +44 1635 2811-11
Fax +44 1635 2811-61
A&Dsales@uk.ebmpapst.com
www.ebmpapst-ad.com

ebm-papst in America and Africa

America

 **Argentina**
 ebm-papst de Argentina S.A.
 Hernandarias 148 Lomas del Mirador
 Pcia. de Buenos Aires (1752)
 ARGENTINA
 Phone +54 11 46576135
 Fax +54 11 46572092
 ventas@ar.ebmpapst.com
 www.ebmpapst.com.ar

 **Brazil**
 ebm-papst Motores Ventiladores Ltda.
 Av. José Giorgi, 301 Galpões B6+B7
 Condomínio Logical Center
 06707-100 Cotia - São Paulo
 BRAZIL
 Phone +55 11 4613-8700
 Fax +55 11 4777-1456
 vendas@br.ebmpapst.com
 www.ebmpapst.com.br

 **Canada**
 ebm-papst Canada Inc.
 1800 Ironstone Manor, Unit 2
 Pickering, Ontario, L1W3J9
 CANADA
 Phone +1 905 420-3533
 Fax +1 905 420-3772
 sales@ca.ebmpapst.com
 www.ebmpapst.ca



 **Mexico**
 ebm Industrial S. de R.L. de C.V.
 Paseo de Tamarindos 400-A-5to Piso
 Col. Bosques de las Lomas
 Mexico 05120, D.F.
 MEXICO
 Phone +52 55 3300-5144
 Fax +52 55 3300-5243
 sales@mx.ebmpapst.com
 www.ebmpapst.com.mx

USA

 ebm-papst Inc.
 P.O. Box 4009
 100 Hyde Road
 Farmington, CT 06034
 UNITED STATES
 Phone +1 860 674-1515
 Fax +1 860 674-8536
 sales@us.ebmpapst.com
 www.ebmpapst.us

 ebm-papst Automotive & Drives, Inc.
 3200 Greenfield, Suite 130
 Dearborn, MI 48120
 UNITED STATES
 Phone +1 313 406-8080
 Fax +1 313 406-8081
 automotive@us.ebmpapst.com
 www.ebmpapst-automotive.us

Africa

 **South Africa**
 ebm-papst South Africa (Pty) Ltd.
 P.O. Box 3124
 1119 Yacht Avenue
 2040 Honeydew
 SOUTH AFRICA
 Phone +27 11 794-3434
 Fax +27 11 794-5020
 info@za.ebmpapst.com
 www.ebmpapst.co.za



ebm-papst in Asia



Asia

China

 ebm-papst Ventilator (Shanghai) Co., Ltd.
 No. 418, Huajing Road
WaiGaoQiao Free Trade Zone
No. 2001, Yang Gao (N) Road
200131 Shanghai
P.R. of CHINA
Phone +86 21 5046-0183
Fax +86 21 5046-1119
sales@cn.ebmpapst.com
www.ebmpapst.com.cn

Hong Kong

 ebm-papst Hong Kong Ltd.
 Room 17E, MG Tower
133 Hoi Bun Road, Kwun Tong
Hong Kong
P.R. of CHINA
Phone +852 2145-8678
Fax +852 2145-7678
info@hk.ebmpapst.com

India

 ebm-papst India Pvt. Ltd.
 26/3, G.N.T. Road, Erukkencherry
Chennai-600118
INDIA
Phone +91 44 25372556
Fax +91 44 25371149
sales@in.ebmpapst.com
www.ebmpapst.in

Indonesia

 ebm-papst Indonesia
 Representative Office
German Centre, 4th Floor, Suite 4470
Jl. Kapt. Subijono Dj. Bumi Serpong Damai
15321 Tangerang
INDONESIA
Phone +62 21 5376250
Fax +62 21 5388305
salesdept@id.ebmpapst.com

Israel

 Polak Bros. Import Agencies Ltd.
 9 Hamefalsim Street
Kiryat Arie, Petach-Tikva 49514
ISRAEL
Phone +972 3 9100300
Fax +972 3 5796679
polak@polak.co.il
www.polak.co.il

Japan

 ebm-papst Japan K.K.
 Attend on Tower 13F
Shinyokohama 2-8-12, Kohoku-ku
222-0033 Yokohama-City, Kanagawa
JAPAN
Phone +81 45 47057-51
Fax +81 45 47057-52
info@jp.ebmpapst.com
www.ebmpapst.jp

Korea

 ebm-papst Korea Co. Ltd.
 6F, Trutech Bldg.
12, WorldCupbuk-ro 56-gil
Mapo-Gu
Seoul 03924
KOREA
Phone +82 2 366213-24
Fax +82 2 366213-26
info@kr.ebmpapst.com
www.ebmpapst.co.kr

Malaysia

 ebm-papst Malaysia
 Representative Office
No. 16-1, Jalan Putra Mahkota 7/5A
Putra Heights
Selangor Darul Ehsan
47650 Subang Jaya
MALAYSIA
Phone +60 3 5192-7688
Fax +60 3 5614-3078
salesdept@my.ebmpapst.com

Philippines

 ebm-papst SEA Pte. Ltd.
 Representative Office (Philippines)
ALPAP II Building
Trade Street Corner Investment Drive
Unit 1101 Madrigal Business Park
1799 Ayala Alabang / Muntinlupa City
Telefon: +63 02 8042747
Telefax: +63 02 8042757
salesdept@ph.ebmpapst.com

Singapore

 ebm-papst SEA Pte. Ltd.
 9 Tai Seng Drive
#03-01 Geo-Tele Centre, Lobby B
Singapore 535227
SINGAPORE
Phone +65 65513789
Fax +65 68428439
salesdept@sg.ebmpapst.com

Taiwan

 ETECO Engineering & Trading Corp.
 10F-I, No. 92, Teh-Wei Str.
Tsow-Inn District, Kaohsiung
TAIWAN
Phone +886 7 557-4268
Fax +886 7 557-2788
eteco@ms22.hinet.net
www.ebmpapst.com.tw

Thailand

 ebm-papst Thailand Co., Ltd.
 99/9 Moo 2, Central Chaengwattana Tower
14th Floor, Room 1402
Chaengwattana Road Bangtarad, Pakkret
11120 Nonthaburi
THAILAND
Phone +66 2 8353785-7
Fax +66 2 8353788
salesdept@th.ebmpapst.com

United Arab Emirates

 ebm-papst Middle East FZE
 PO Box 17755
Jebel Ali Free Zone / FZS1 / AP05
Dubai
UNITED ARAB EMIRATES
Phone +971 4 88608-26
Fax +971 4 88608-27
info@ae.ebmpapst.com
www.ebmpapst.ae

Vietnam

 ebm-papst SEA Pte. Ltd.
 Representative Office
Room 402, 4th Floor, Saigon 3 Building
140 Nguyen Van Thu Street
Dakao Ward, District 1
Ho Chi Minh City
VIETNAM
Phone +848 3910 4099
Fax +848 3910 3970
salesdept@vn.ebmpapst.com

ebm-papst in Oceania

Oceania



Australia



ebm-papst A&NZ Pty Ltd.
10 Oxford Road
Laverton North, Victoria, 3026
AUSTRALIA
Phone +61 3 9360-6400
Fax +61 3 9360-6464
sales@ebmpapst.com.au
www.ebmpapst.com.au



New Zealand



ebm-papst A&NZ Pty Ltd.
61 Hugo Johnston Drive, Unit H
Penrose 1061, Auckland
NEW ZEALAND
PO Box 112278,
Penrose 1642, Auckland
Phone +64 9 525-0245
Fax +64 9 525-0246
sales@ebmpapst.com.au
www.ebmpapst.com.au



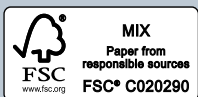

ebm-papst
Mulfingen GmbH & Co. KG

Bachmühle 2
74673 Mulfingen
Germany
Phone +49 7938 81-0
Fax +49 7938 81-110
info1@de.ebmpapst.com

ebmpapst

The engineer's choice